

Queensland Electricity Connection and Metering Manual

Service and Installation Rules

Issued Date: 01/12/2017, Effective Date: 01/12/2017



Part of the Energy Queensland Group

QLD Electricity Connection and Metering Manual



Part of the Energy Queensland Group

THIS PAGE HAS BEEN DELIBERATELY LEFT BLANK

Table of Contents

Distributors Contact Details	1
Dial Before You Dig	2
Foreword	3
Purpose and Scope	4
Definitions, Abbreviations and Acronyms.....	4
References	5
Responsibilities	6
1. Important Information	17
1.1. Use of this document.....	17
1.2. Scope.....	17
1.3. Failure to comply with this manual.....	18
1.4. Exceptional Circumstances	18
1.5. Enquiries	18
1.6. Distributors Contact Details for QECMM Correspondence.....	19
1.7. Historic Buildings and Flora with Vegetation Protection Orders	19
1.8. Revisions and alterations.....	19
1.9. Drawings	19
2. Customers Installations.....	21
2.1. Request for Electrical Connection.....	21
2.2. Request for Initial Connection, Service Alteration, Metering Change or Inverter change	21
2.3. Alterations and Additions	22
2.4. Breaking of Metering Terminal Cover/Metering Isolation Link/Metering Neutral Link Seals	22
2.5. Examination, Test and Connection	23
2.6. Unmetered Supplies	23
2.7. Identification in Multiple Installations.....	23
2.8. Protective Fault Current Devices	23
2.9. Power Factor	24
2.10. Limitations on Starting Currents of AC Motors	24
2.11. Interference with Supply of Electricity to Other <i>Customers</i>	26
2.12. High Voltage Installations	26
2.13. <i>Customer's</i> Generating Plant.....	27
2.14. Determination of Maximum Demand	27
2.15. Requirement for Circuit Breakers in Rural/Isolated Areas.....	28
3. Determination of the Number of Phases to be Installed	29
3.1. General	29
3.2. Urban Areas	29
3.3. Non-Urban Areas	29
4. Balancing of Load and Limitation on Equipment	31
4.1. General	31
4.2. Connection of Equipment - Current Limitations.....	31

QLD Electricity Connection and Metering Manual



Part of the Energy Queensland Group

4.3.	Equipment Having Fluctuating Loads	32
4.4.	Harmonic Interference or Wave Form Distortion	32
4.5.	Rectifiers	33
4.6.	Connection of Equipment - Voltage Limitations	33
4.7.	Connection of Equipment - Isolated Generation Localities.....	33
5.	Service Lines and Connection point	35
5.1.	General	35
5.2.	Connection point (Consumer's Terminals).....	35
5.3.	Service Lines.....	35
5.4.	Overhead Service Lines	36
5.5.	Underground Service Lines	41
5.6.	Additional Service Lines in Urban Areas.....	43
5.7.	Additional Service Lines in Non-Urban Areas	43
5.8.	Alterations to Service Lines	43
5.9.	Consumer's mains on the Distributor's Poles.....	44
5.10.	Substations on <i>Customer's</i> Premises	44
5.11.	Joints in Consumer's mains.....	45
6.	Metering Requirements.....	63
6.1.	General	63
6.2.	Metering Determination	63
6.3.	Controlled loads	64
6.4.	<i>Customers</i> Energy Management Systems.....	64
6.5.	Sealing of Metering Equipment.....	64
6.6.	Metering Isolation	64
6.7.	Metering Active and Neutral Requirements	68
6.8.	Conductor Identification.....	70
6.9.	Metering requirements for a Builder's Temporary Service (BTS)	71
6.10.	Metering and Control Equipment - Accommodation.....	71
6.11.	Metering and Control Equipment - Position	71
6.12.	Metering and Control Equipment - Housing	75
6.13.	Metering and Control Equipment – Spacing Requirements.....	76
6.14.	Metering and Control Equipment - Mounting	76
6.15.	Metering Locks.....	78
6.16.	Current Transformer Metering - General Requirements.....	78
6.17.	Current Transformer Equipment supplied by the Distributor	78
6.18.	Current Transformer Selection	78
6.19.	Current Transformer Metering - Housing	79
6.20.	Current Transformer Metering – Installation Requirements.....	80
6.21.	Current Transformer Metering – Meter Panels.....	81
6.22.	Spacing between Meters and Heavy Current Carrying Conductors	82
6.23.	Current Transformer Metering – Additional Requirements.....	83
	Electrical Contractor's LV CT Metering Check Sheet	87
7.	Controlled Supplies - Method of Control.....	101
7.1.	General	101
7.2.	Network Devices	101
7.3.	Contactors for Control of Non-Continuous Load.....	102
7.4.	Size of Network Device Wiring	102

QLD Electricity Connection and Metering Manual



Part of the Energy Queensland Group

8. Arrangements for Micro Embedded Generating Units Connected to the Distribution Network.....	113
8.1. Explanation of Metering Schemes Available.....	113
8.2. Agreements.....	113
8.3. Approval of Equipment.....	113
8.4. Connection Requirements for Micro Embedded Generating Units.....	114
8.5. Labelling Requirements to AS 4777.....	114
9. High Voltage Metering.....	117
9.1. General Requirements.....	117
9.2. Testing Requirements.....	117
9.3. Operation of High Voltage Equipment.....	117
9.4. Maintenance and Repairs of High Voltage Equipment.....	117
9.5. Conversion from Low Voltage Supply to High Voltage Supply.....	117
9.6. Metering Requirements.....	118
9.7. Establishing a Network Connection and <i>NMI</i>	118
9.8. Offer of Supply Letter and/or Network Connection Agreement.....	118
9.9. Connection point.....	118
9.10. Revenue Metering.....	119
9.11. Meter Enclosure.....	120
9.12. Secondary Wiring.....	121
Appendix A - Specification for Metallic Enclosures for Meters in Direct Connected Installations.....	123
A.1 Scope and General.....	123
A.2 Design and Construction.....	123
A.3 Dimensions.....	125
Appendix B - Glossary of Terms.....	127
Appendix C - Amendment Record.....	133
Appendix D – Power of Choice Exempt Areas.....	135
D.1 Metering Requirements.....	135
D.2 Installation Requirements for Meters and Control Equipment.....	137
D.3 Controlled Supplies - Method of Control.....	139
D.4 Installation Requirements for Low Voltage Current Transformer Metering.....	139

DISTRIBUTORS CONTACT DETAILS

Energex

Web Address	www.energex.com.au
<i>EWR</i> (Form 2) Enquiries,	1300 762 397 - Electrical Contractor Line - or
CT Metering Order Form	www.energex.com.au/service_providers/electrical_contractors.html
General Customer Service	13 12 53
Loss of Supply	13 62 62
Emergencies	13 19 62
C&I Substation Manual	Available from Technical Documents section of Energex website: www.energex.com.au
Metering Locks	www.energex.com.au/residential-and-business/reading-your-meter/energex-locks
Technical Information - QECMM enquiries.	1300 762 397

Ergon Energy

Web Address	www.ergon.com.au
<i>EWR</i> (Form A) and CT Metering Order Form	Available from Electrical Contractors section of Ergon Energy website: www.ergon.com.au
General Customer Service	13 74 66 For all areas - New Applications, Point of Attachment Site Visits, Breaking Meter Seals. E-mail requests can be sent to networkenquiries@ergon.com.au or by completing the Contact Form as provided under "Contact Us" on Ergon Energy's Web site: www.ergon.com.au
24 Hour Faults and Emergencies	13 22 96
Metering Locks	1800 233 333 toll free number. Metering Locks can be purchased from API Locksmiths (Queensland Locksmiths) by phone or on-line at www.queenslandlocksmiths.com.au .
Technical Information - QECMM enquiries.	1800 237 466 Electrical Contractor Hotline (EC Use only)

Ergon Energy – Metering Locks - Trade Orders

The API Locksmiths (Queensland Locksmiths) ordering system has primarily been set up for lock sales to individual *customers* where *customer* details are required, and passed on to Ergon Energy for updating in the *Customer* Information System. However the system has also been set up to cater for "Trade Orders". These Trade Orders allow electrical contractors, switchboard manufacturers and Ergon Energy staff to purchase metering locks without the requirement to provide *customer* information. It is necessary to advise API Locksmiths (Queensland Locksmiths) when phoning that a Trade Order is required. The Trade Order section is also available via the web site.

People utilising the Trade Order section are requested to provide *customer* and location details to Ergon Energy as soon as the metering lock is installed, so this can be recorded in the *Customer* Information System.

DIAL BEFORE YOU DIG



Phone 1100 - free call (except from mobiles) Fax 1300-652-077

Website www.1100.com.au

Dial before you Dig is the national referral service for information on the location of underground infrastructure.

Australia's major service providers have a single web-enabled information service for information on the location of underground communications, gas, water and electricity infrastructure.

The Dial before you Dig online service is available 24 hours a day and enables users to have more control over their enquiry as you detail the dig site on the mapping software yourself.

Use the website to ensure that you 'Dial Before You Dig' before any excavation work.

When calling the 1100 phone number the operator may require the following:

- your name and address
- name of company
- contact telephone number
- fax number for return information
- contact name on site
- site address and both nearest cross streets
- start date of proposed work
- type of work being carried out

Note: Section 62 of the Queensland Electrical Safety Regulation 2013 has requirements for excavating near underground electrical services.

FOREWORD

The Queensland Electricity Connection and Metering Manual (*QECMM*) has been compiled in conjunction with the Network Engineering Standards Department of *Energex* and the Network Standards Department of *Ergon Energy* and is the same jurisdictional document referred to as the Electricity Connection and Metering Manual (ECMM) in the Metrology Procedure: Part A National Electricity Market.

Note: Printed versions of the *QECMM* are “uncontrolled copies” - the latest version is available on the *Energex* website (www.energex.com.au) or *Ergon Energy* website (www.ergon.com.au).

Safety

In all activities undertaken, the safety of our employees, contractors, *customers* and the community is paramount. Safety is our number one value and there is a commitment to ensuring that "safety must come first" to achieve a no injuries workplace. In accordance with legislative requirements we have developed Policies, Standards and Work Practices that our workers are required to follow to ensure the safety of themselves, other workers, *customers* and the community. We trust that electrical contractors and persons in control of sites will appreciate that our workers will not undertake any work in a situation where there are uncontrolled risks inconsistent with our safe systems of work.

Disclaimer

Whilst the *QECMM* contains material relevant to the electricity industry legislation, codes of practice and standards, it is not intended to provide legal advice on how *electrical contractors* can meet their own statutory obligations or comply with legislation, codes of practice or industry standards such as AS/NZS 3000 (Wiring Rules).

The *QECMM* does not provide advice for the purposes of section 64A of the *Electrical Safety Regulation 2013*. The *Electrical Safety Act 2002*, *Electrical Safety Regulation 2013* and associated codes of practice establish requirements for electrical safety and place obligations on employers, self-employed persons and others. These documents may be obtained from the Queensland Government website (www.justice.qld.gov.au).

Whilst care has been taken in the preparation of the *QECMM*, the distribution entities do not guarantee that the information contained in the *QECMM* is accurate, complete or up to date at time of publication. To the extent permitted by the relevant legislation the *distributor* will not be responsible for any loss, damage, cost or expense incurred as a result of any error, omission or misrepresentation in relation to the information contained in the *QECMM*.

Copyright

Copyright © 2017 Energex Limited and Ergon Energy Corporation Limited. This publication is copyright. Except as permitted under the Copyright Act 1968 no part of this publication may be reproduced by any process without the specific written permission of the copyright owner.

All rights reserved.

QLD Electricity Connection and Metering Manual



Part of the Energy Queensland Group

PURPOSE AND SCOPE

The purpose of this manual is to promote industry uniformity through standardisation of practices throughout Queensland. The document is for use by *Electrical Contractors*, Consulting Engineers, Architects, *Metering Providers* and others directly concerned with electrical installations that are connected, or are to be connected, to the respective supply network.

Metering installation compliance and obligations contained in this manual forms part of the (Queensland) *Electricity Distribution Network Code* and the *National Electricity Rules*.

DEFINITIONS, ABBREVIATIONS AND ACRONYMS

Unless otherwise stated definitions, abbreviations and acronyms used in AS/NZS 3000 (Wiring Rules) and the current Legislation referenced in the *QECMM* have the same meaning when used in this document.

Refer to the Glossary of Terms for general definitions.

Note: Words and terms defined in the Glossary are identified within the text by italicising (e.g. *distributor*).

REFERENCES

Referenced Legislation:

Electricity Act 1994 (Qld)
Electricity Regulation 2006 (Qld)
Electricity Distribution Network Code (made under the Electricity Act 1994 (Qld))
Electrical Safety Act 2002 (Qld)
Electrical Safety Regulation 2013 (Qld)
Electrical Safety Code of Practice 2010 – Working near exposed live parts
Queensland Government Gazette – Notified Prices (Tariff Gazette, <http://www.qca.org.au>)
Work Health and Safety Act 2011 (Qld)
National Electricity Rules

Referenced Standards:

AS 1243	Voltage transformers for measurement and protection
AS/NZS 1269.1	Occupational noise management - Measurement and assessment of noise immission and exposure
AS 1284.4	Electricity metering Socket mounting system
AS 1397	Steel sheet and strip - hot dip zinc-coated or aluminium/zinc-coated
AS 1657	Fixed platforms, walkways, stairways and ladders - Design construction and installation
AS 2067	Substations and high voltage installations exceeding 1kV ac
AS/NZS 3000	Wiring Rules
AS/NZS 3012	Electrical installations - Construction and demolition sites
AS 4645.1	Gas distribution networks – Network management
AS 4777.1	Grid connection of energy systems via inverters - Installation requirements
AS 4777.2	Grid connection of energy systems via inverters - Inverter requirements
AS 4777.3	Grid connection of energy systems via inverters - Grid protection requirements
AS 5601	Australian Gas Code
AS 6002	Domestic electricity meter enclosures
AS 60044 series	Instrument transformers
AS/NZS 60079.10.1	Classification of hazardous areas - Examples of area classification - Flammable gases
AS 60269 series	Low-voltage fuses
AS 60529	Degrees of protection provided by enclosures (IP Code)
AS 60974.6	Arc welding equipment - Welding power sources
AS/NZS 61000 Series	Electromagnetic compatibility (EMC)
AS/IEC 62196	Plugs, socket-outlets, vehicle connectors and vehicle inlets – Conductive charging of electric vehicles
EE STNW1170/ EX STD01143	Connection Standard for Small Scale Parallel Inverter Energy Systems up to 30kVA

RESPONSIBILITIES

The *Customer*:

- selects an electricity *retailer*;
- where applicable, negotiates or nominates an agent to negotiate provision of the electricity supply with the *distributor*;
- contacts their *retailer* when advised by an *electrical contractor*;
- for initial connections, the *customer* is responsible to ensure trees are cut/trimmed to provide clear access for an overhead service;
- provides a safe working environment for the *electrical contractor*, meter reader, etc;
- ensures the meter enclosure is accessible at all times. If behind a locked gate ensures that the gate is fitted with the *distributor's* metering lock;
- ensures the meter enclosure is clear of vegetation and that the meter reader can read the meter without stepping on, or damaging valuable plants etc;
- ensures that the *connection point* is clear at all times to allow safe access by the *distributor's* personnel;
- notifies the *retailer*, *distributor* and *metering provider* where applicable, when supply is to be permanently disconnected from a *premises* (supply abolishment).
- contacts the *retailer* prior to any work being done that may impact on the metering installation.

The Relevant *Distributor*:

- negotiates provision of the electricity supply with the *customer* or the *customer's* agent (generally an *electrical contractor*);
- transports and delivers electricity which is purchased by *retailers* and sold to *customers*;
- examines and tests the *consumer's mains*, main switchboard and main earth of a *customer's* installation before it is initially connected to the *distributor's* electricity network;
- may be the *metering provider*;
- provides the *Distributor Network Devices*;
- connects the electricity supply to a *customer's* installation up to the load side of the Metering Isolation Links (subject to rectification of any defects) and subject to the *customer* selecting a *retailer*, and the *retailer* requesting the connection;
- is responsible for the reliability and quality of the electricity supply at the *connection point*;
- is responsible for the issue of *NMIs* (refer to local *distributor's* web site for guidelines).

The *Metering Provider*:

The *metering provider* must be accredited by AEMO and shall comply with the following responsibilities;

- when appointed by the *metering coordinator*, they are to supply, install and maintain the metering equipment on a *customer's* premises in accordance with this QECMM,
- to return to the *distributor* or *metering provider* any *distributor's* or *metering provider's* assets removed from a *customer's* metering panel within 5 business days,
- to ensure all *customer* energy is metered and to notify by the appropriate notification form to the *distributor* any unmetered circuits identified,
- notify the *distributor* immediately and cease any work if evidence of tampering of metering or control equipment is detected,
- retain or utilise *distributor's* network devices where the *customer* requires controlled tariffs,

QLD Electricity Connection and Metering Manual



Part of the Energy Queensland Group

- where the distributor is the *metering provider*, comply with *distributor's* requirements for installation, sealing and testing of metering equipment,
- where the *metering provider* is not the *distributor*, notify the *distributor* by the appropriate process prior to conducting any onsite works,
- the *metering provider* shall attach a label to the metering installation detailing the *NMI*, the *metering provider* and *metering provider* contact details,
- ensure that all safety and security requirements are maintained for all types of metering installations,
- inspect and confirm the metering installation is compliant with this *QECMM* and safety requirements, and issue corrective action notices if defects exist.

The Relevant *Retailer*:

- purchases electricity and sells it to *customers*;
- nominates prices and negotiates contracts where applicable, for the sale of electricity to *customers*;
- where the *distributor* is not the *metering provider*, provides the *distributor* with details of the *metering coordinator* and/or *metering provider*;
- requests the *distributor* to connect, disconnect or alter the *customer's* installation in accordance with the *customer's* contract (*SOR* if applicable).

The *Electrical Contractor*:

- ensures all electrical work is in accordance with Queensland Legislation, AS/NZS 3000 (Wiring Rules), other relevant Standards and the requirements of the *QECMM* (in particular ensuring that unterminated cables cannot be energised by inserting a fuse or link or by closing a switch or circuit breaker);
- where 'exceptional circumstances' occur, ensures that permission is obtained by submitting a written request to the *distributor* for a variation;
- ensures that the *distributor* is advised when there is a significant increase in the electrical load at an installation;
- advises the *customer* when increases in load require changes to the electrical installation including meter changes;
- must not work on or remove metering equipment unless they are the appointed *metering provider*;
- on completion of electrical work that involves metering or metering alterations, advises the *customer* that they must contact the *retailer* and notify that the work is complete (See note in Clause 2.2);
- issues the *customer* with a certificate of testing and compliance;
- submits appropriate forms in a timely manner and ensures that the information on the forms is accurate (e.g. correct address);
- notifies the *metering provider* of any broken metering seals;
- notifies the *distributor* of any broken *network device* seals;
- rectifies any departures from this manual that have been identified by the *distributor*;

The *Electrical Consultant*:

- designs the electrical installation in accordance with Queensland Legislation, AS/NZS 3000 (Wiring Rules), other relevant Standards and the requirements of this manual;
- where 'exceptional circumstances' occur, ensures that permission is obtained by submitting a written request to the *distributor* for a variation;

QLD Electricity Connection and Metering Manual



Part of the Energy Queensland Group

- on large projects liaises with the *distributor* to ensure adequate supply is available when required;
- ensures that the *distributor* is advised when there is a significant increase in the electrical load at an installation;
- advises the *customer* when increases in load require changes to the electrical installation including meter changes.

Stakeholder Interaction Diagrams:

The following diagrams have been included as a guide to assist the users of this manual to understand the process interaction between the *customer*, *electrical contractor*, *retailer*, *distributor* and *metering provider*.

- 1) Initial Connection - *Direct Connected Metering*;
- 2) Initial Connection - *Current Transformer Metering*;
- 3) Electrical Installation Work Involving Metering Changes;
- 4) Service and Metering Change - Additional Phases;
- 5) Service Alteration - No Metering Changes;
- 6) *MEGU* Connection to the Distribution Network;
- 7) Initial Connection - High Voltage Installation.

QLD Electricity Connection and Metering Manual



Part of the Energy Queensland Group

1) Initial Connection - Direct Connected Metering

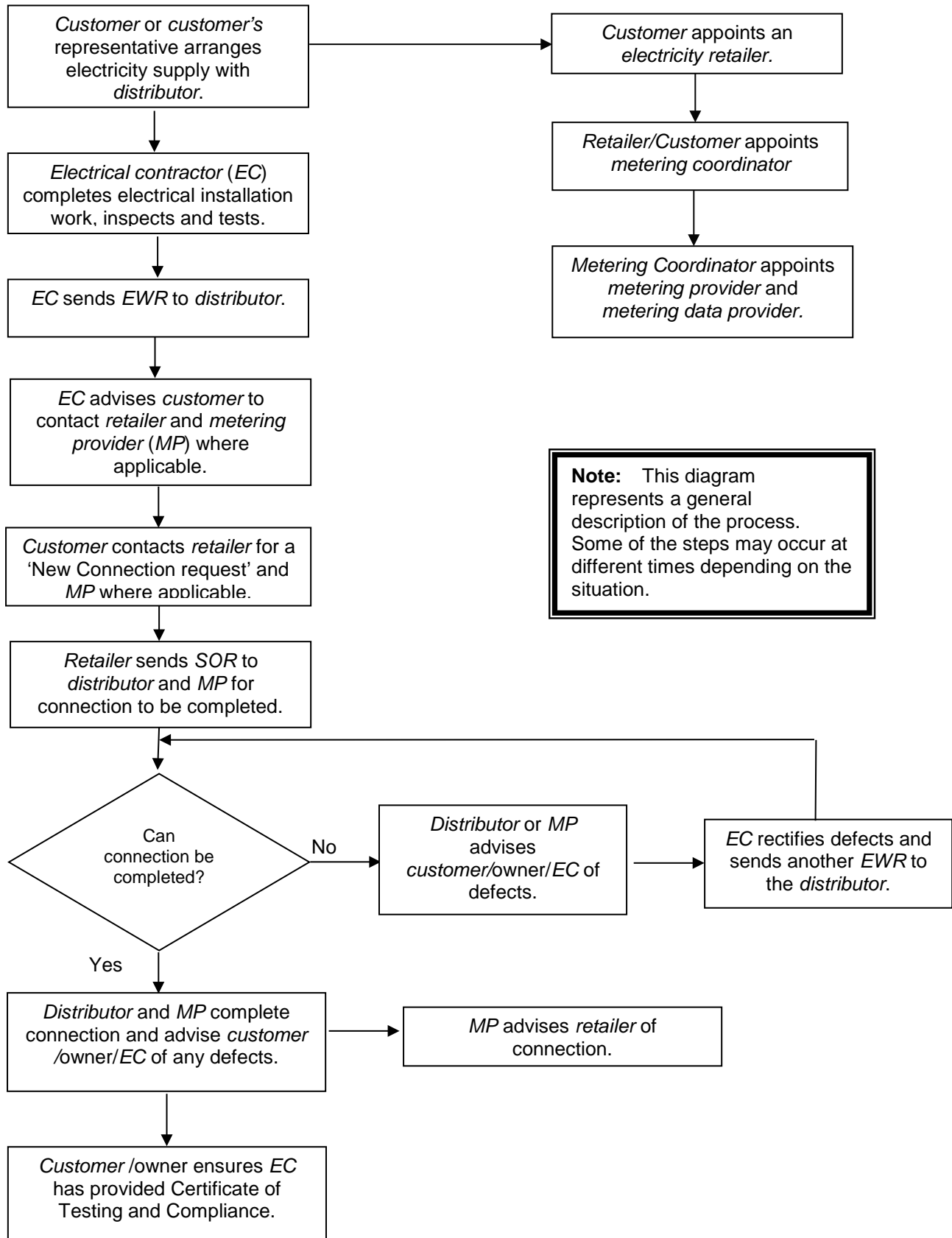

2) Initial Connection - LV Current Transformer Metering

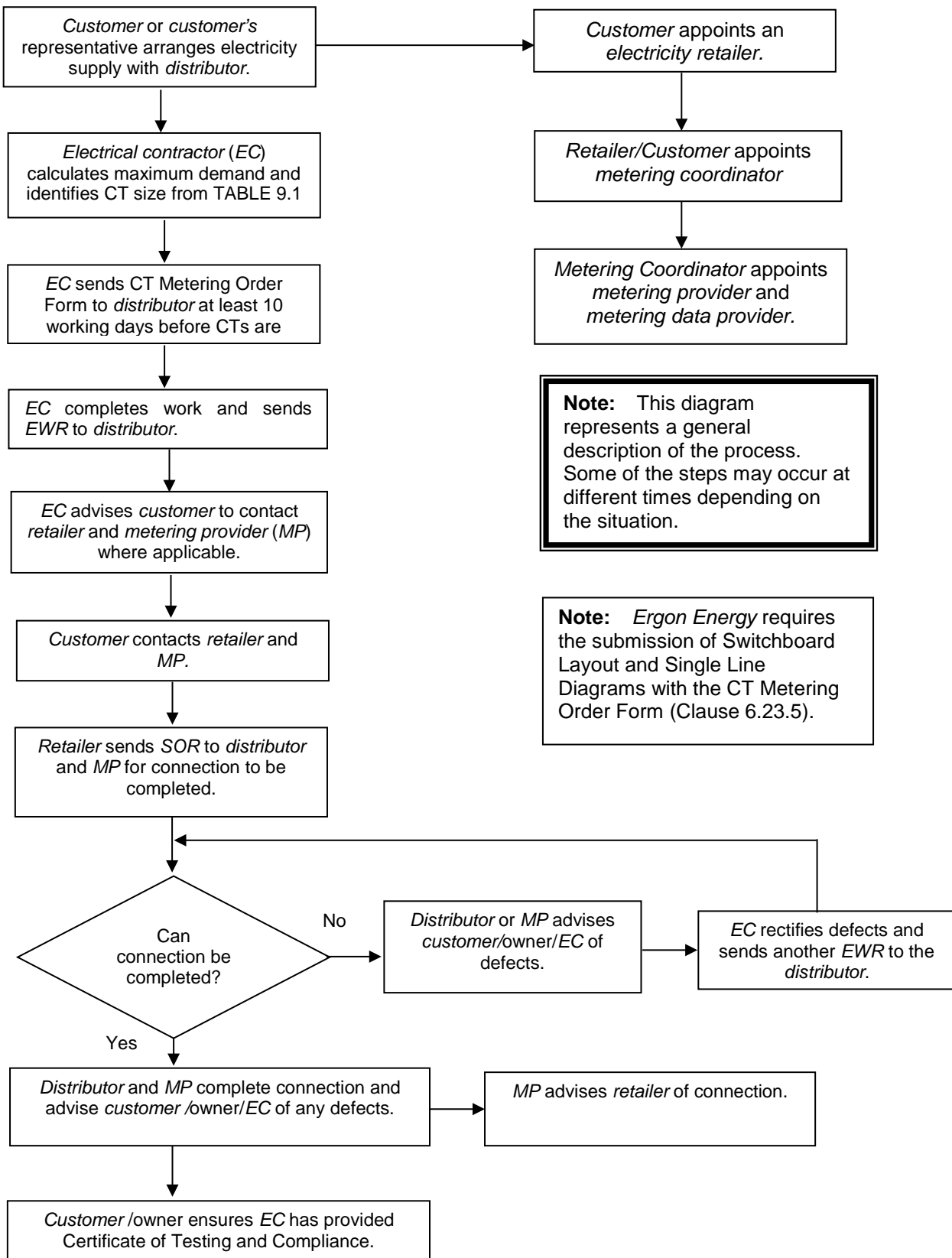

3) Electrical Installation Work Involving Metering Changes

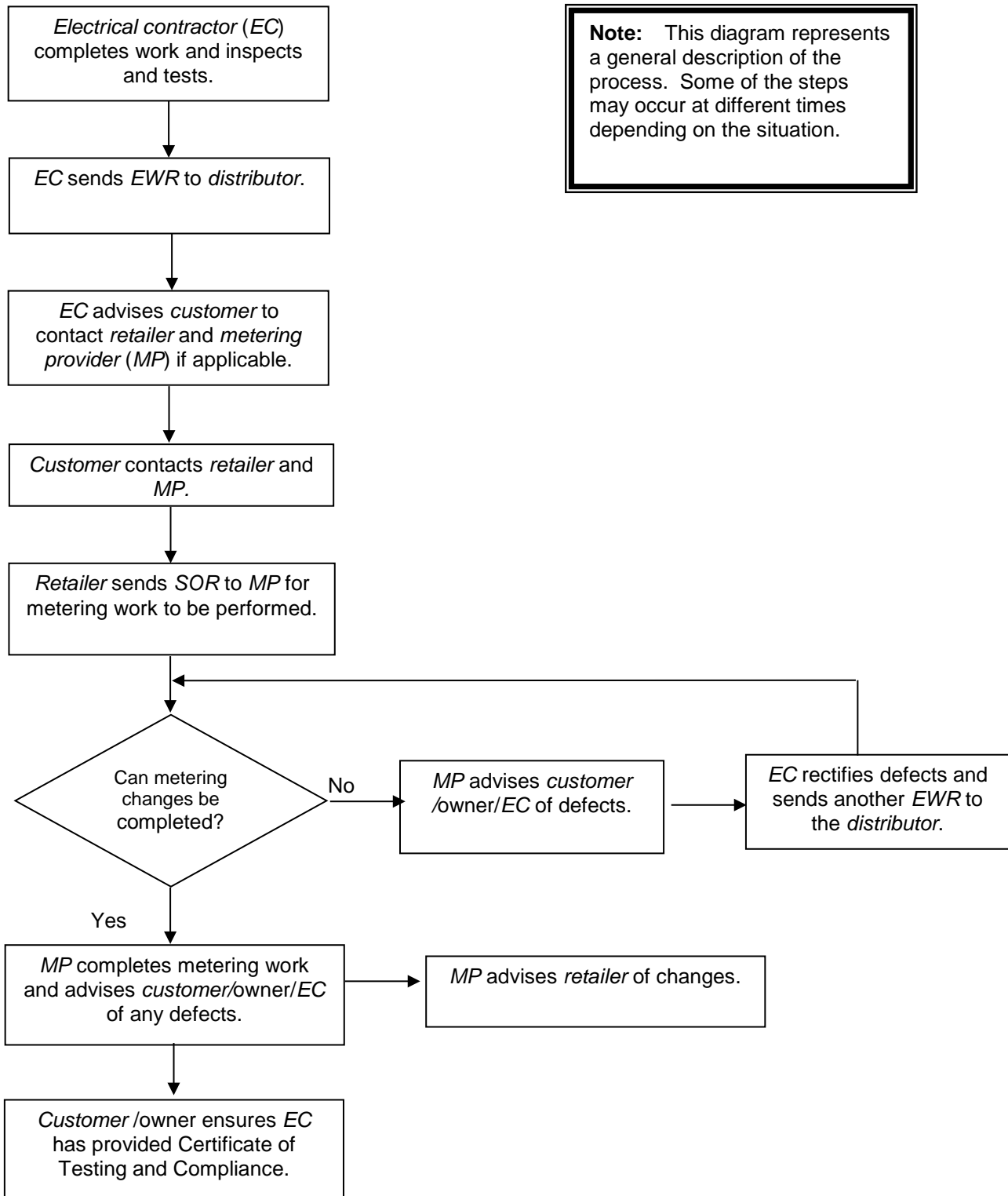

Note: This diagram represents a general description of the process. Some of the steps may occur at different times depending on the situation.

4) Service and Metering Change - Additional Phases

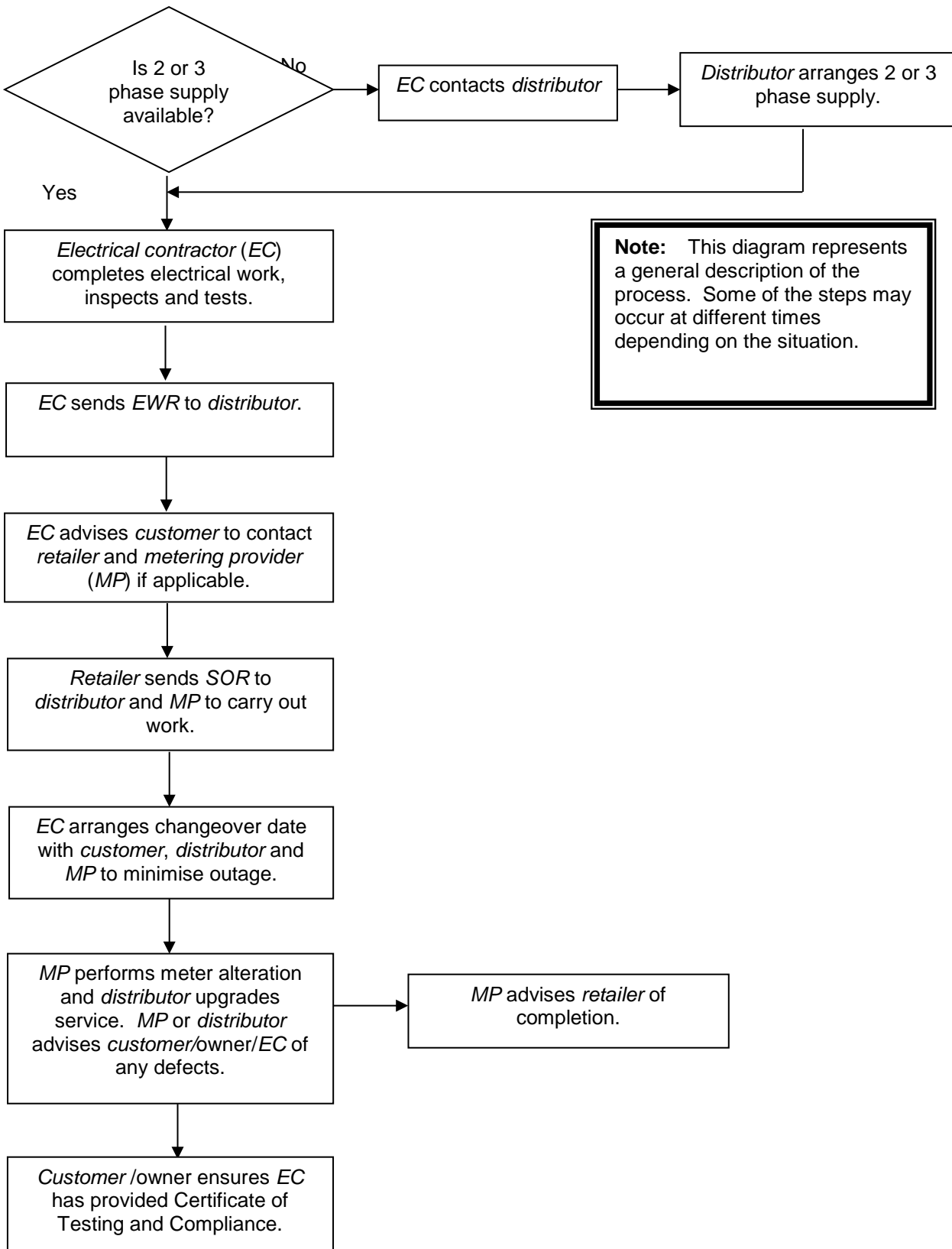

Note: This diagram represents a general description of the process. Some of the steps may occur at different times depending on the situation.

5) Service Alteration - No Metering Changes

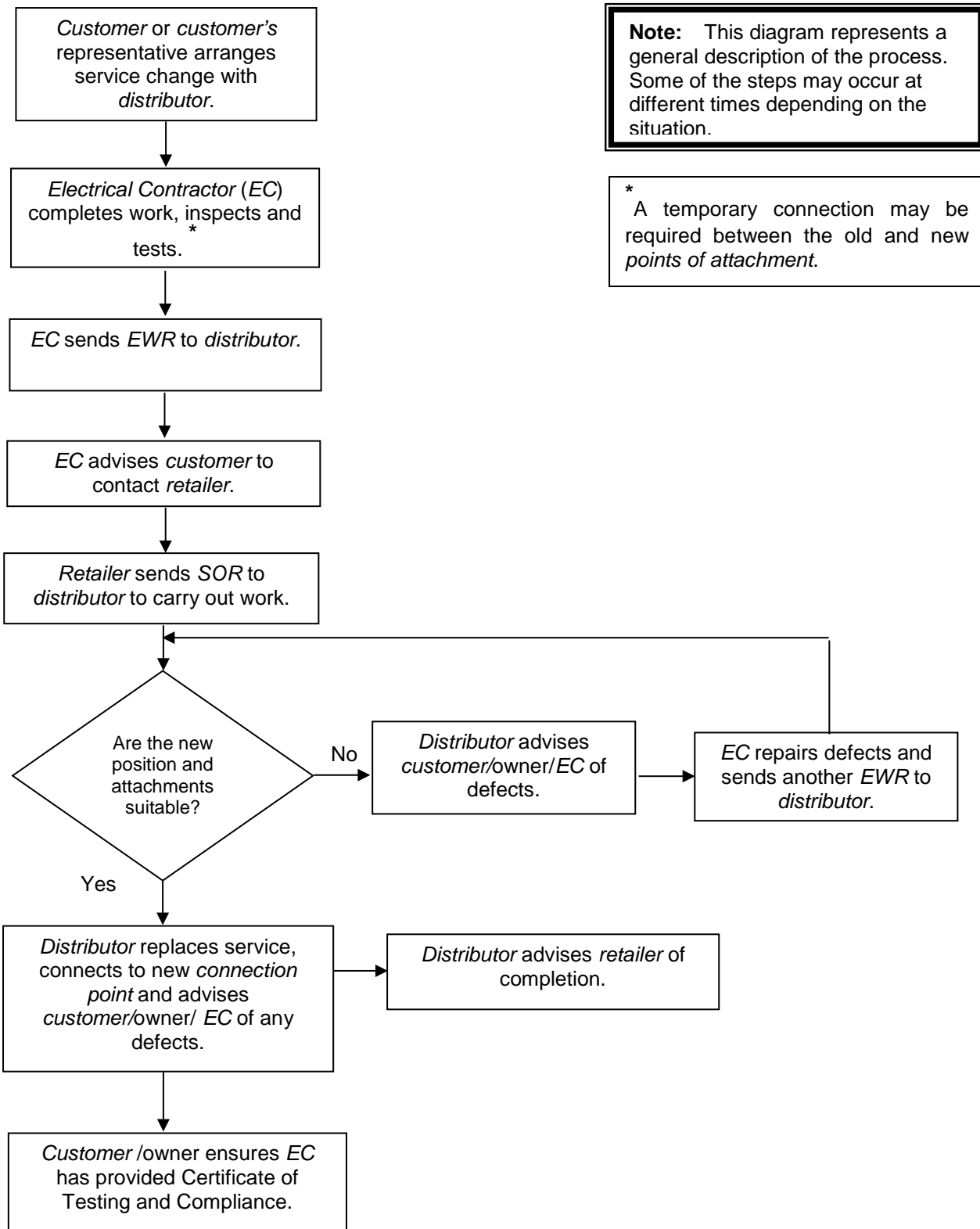

Note: This diagram represents a general description of the process. Some of the steps may occur at different times depending on the situation.

* A temporary connection may be required between the old and new points of attachment.

6) MEGU Connection to the Distribution Network

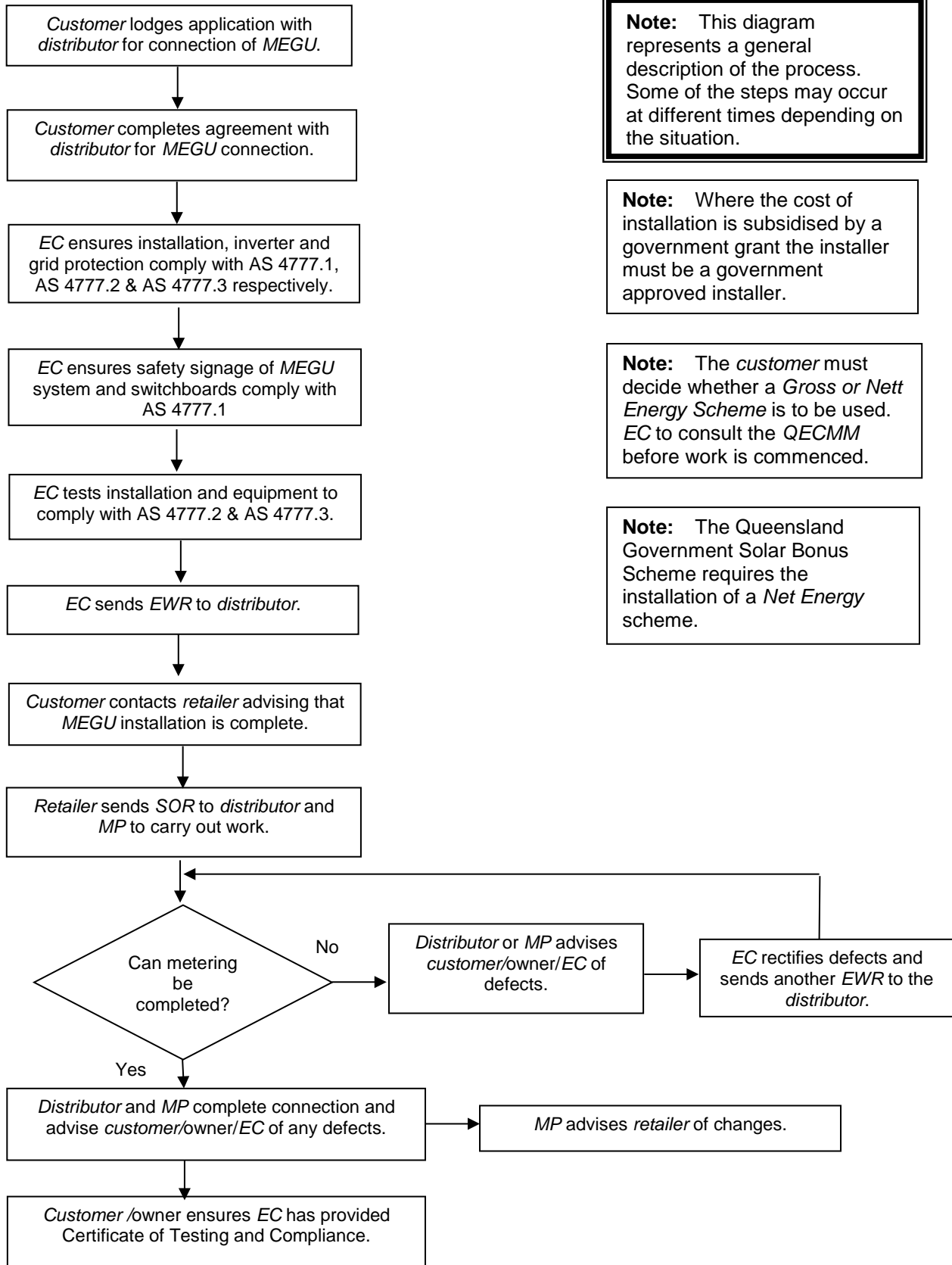

Note: This diagram represents a general description of the process. Some of the steps may occur at different times depending on the situation.

Note: Where the cost of installation is subsidised by a government grant the installer must be a government approved installer.

Note: The customer must decide whether a Gross or Nett Energy Scheme is to be used. EC to consult the QECMM before work is commenced.

Note: The Queensland Government Solar Bonus Scheme requires the installation of a Net Energy scheme.

7) Initial Connection - High Voltage Installation

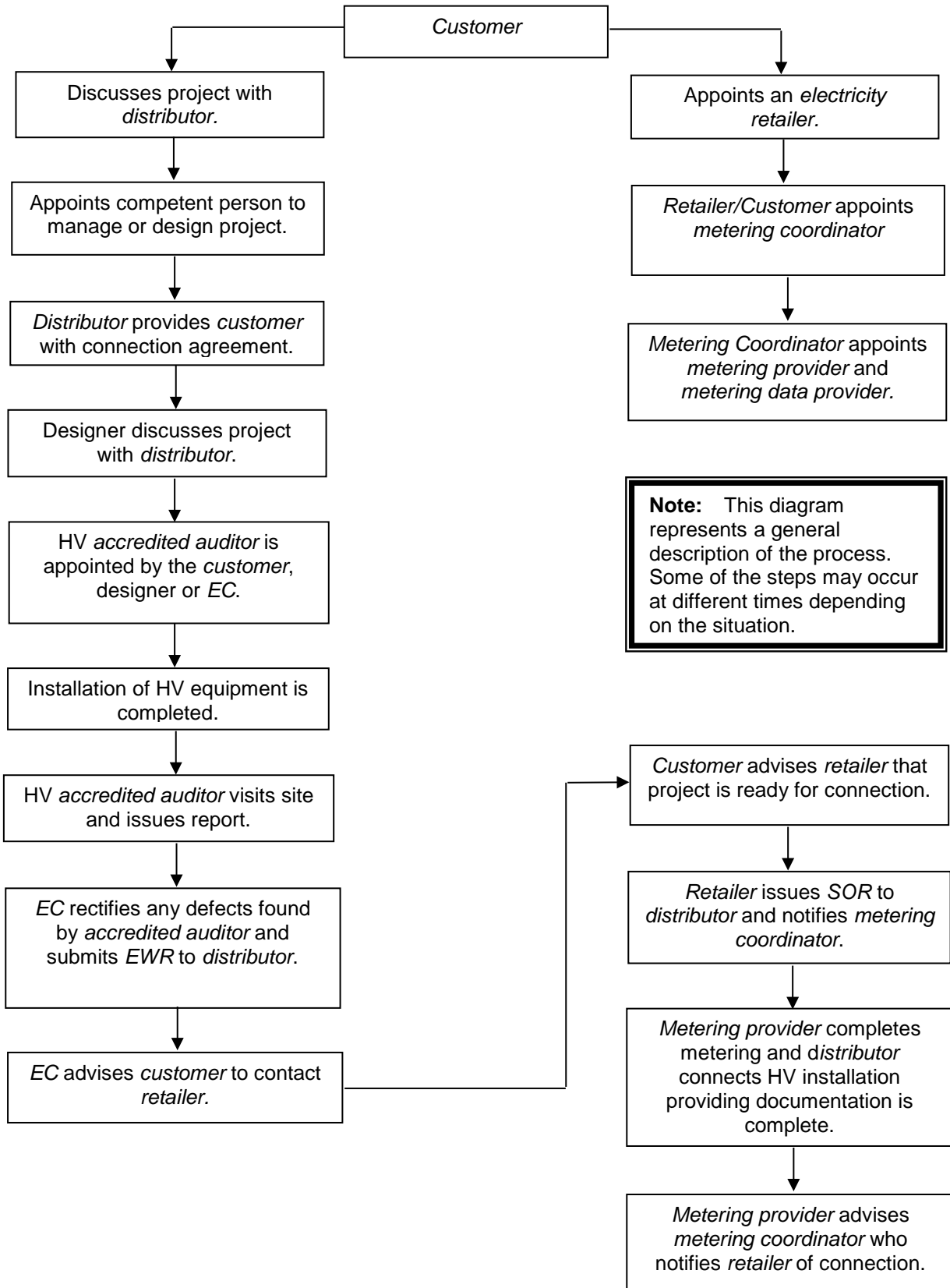

QLD Electricity Connection and Metering Manual



Part of the Energy Queensland Group

THIS PAGE HAS BEEN DELIBERATELY LEFT BLANK

1. IMPORTANT INFORMATION

1.1. Use of this document

This document is to be read in conjunction with the current:

- (a) Australian Standards, in particular AS/NZS 3000 (Wiring Rules).
- (b) Relevant Legislation and respective Regulations and Codes (see References pg 5).
- (c) The *National Electricity Rules*.
- (d) QECMM addendums published in relation to specific topics (on and from the date they are published).

Note: The requirements of the Queensland Electricity Legislation are to be considered in the design, installation, operation and maintenance of the *customer's* electrical installation

This is a self-contained document except where it specifically refers to other related documents and supersedes previous versions of both the *Energex* and *Ergon Energy* Electricity Connection and Metering Manuals.

Sections 1 – 8 of this document apply to all premises connected to the National Electricity Market. In addition to Section 1-8, Appendix D also applies to all premises connected to an *Isolated Power System*, or part of the Mt Isa supply network

1.2. Scope

This document provides guidelines for connection of supply, metering and load control arrangements of a *customer's* installation.

Where departures from these guidelines may be necessary, prior consultation with the *distributor* will be required. (Refer to Clause 1.4, Exceptional Circumstances).

Note: If there is any inconsistency between the guidelines provided in the *QECMM* and -

- (a) the relevant legislation (i.e. the *Electricity Act 1994*, the *Electrical Safety Act 2002* and their respective Regulations or Codes of Practice), AS/NZS 3000 (Wiring Rules) and the *National Electricity Rules*, or
- (b) the terms contained in a *distributor's* letter of offer to supply, or a connection agreement;

then the relevant legislation set out above at clause 1.2 (a), shall prevail in the first instance, followed by Clause 1.2 (b), the terms of a letter of offer to supply or a connection agreement.

1.2.1 Small Customers

The conditions of supply and metering requirements detailed in this document apply for all *customers* who consume less than 100MWh per annum (i.e. a *Small Customer*) and are connected to the *distributor's* electricity network.

1.2.2 Large Market Customers

The conditions of supply and metering for *customers* who are Registered Participants according to *National Electricity Rules*, consume 100MWh or more annually and have an Electricity Sales Contract with a *retailer* are detailed in the *National Electricity Rules* Chapter 5 - Network Connection.

Where specific detail is not covered by the *National Electricity Rules* the requirements of this document apply. Connections for new *large customers* must comply with the *Queensland Electricity Regulation 2006*.

1.2.3 Un-metered Supplies

The conditions of supply for *customers* whose *connection point* is not metered, and are connected to the distribution network, are detailed in this document.

1.2.4 Remote Generated Areas

The conditions of supply and metering requirements detailed in this document apply to all *customers'* installations and are to be read in conjunction with *Ergon Energy* document PW000202R114 - "Guidelines for Electrical Installations at Isolated Systems." Call *Customer Service* (refer page 1).

1.3. Failure to comply with this manual

Should an installation not satisfy the requirements of these and/or other applicable rules, the connection of electricity supply may be **delayed** or **withheld**, and installations with supply may be **disconnected**, until such time as the non-compliance(s) has been rectified.

1.4. Exceptional Circumstances

In exceptional circumstances the stated requirements contained within the *QECMM* may be waived and/or modified by the submission of a written request to the relevant *distributor*. (Refer to Clause 1.6 for contact details).

The request shall include all of the following:

- (a) A detailed statement of the reasons why non-compliance with this manual is sought.
- (b) Full details and diagrams, as necessary, showing the specific aspect of a requested variation to the *QECMM*.
- (c) Property location details.

No action or variation should be undertaken until a written approval from the *distributor*, has been received.

Note: Any variation approval will **only apply to the individual property** as listed in the request (i.e. it does not cover, or set any precedent, for any other installation).

1.4.1 Request for an interpretation of the QECMM

A request for an interpretation of the *QECMM* must be made in writing to the relevant *distributor*. A reply will be provided by the *distributor* within 10 working days from receipt of the written request.

1.4.2 Request for dispensation from the QECMM

A request for dispensation from the requirements of the *QECMM* must be made in writing to the relevant *distributor*. A reply will be provided within 10 working days from receipt of the written request.

1.4.3 Request for an QECMM amendment

A request for an amendment of the *QECMM* must be made in writing to the relevant *distributor*. Acknowledgement of receipt of the amendment will be provided within 10 working days from receipt of the written request.

1.5. Enquiries

Unless indicated, enquiries are to be by email or by written communication.

1.5.1 Enquiries before the work commences or while the work is underway.

Contact the phone numbers on page 1 of the *QECMM*.

1.5.2 Enquiries regarding defects identified by the *distributor*

Contact the *distributor* advising the following information:

- (a) *Customer* name and address and *NMI* if available;
- (b) Reference number on the *distributor's* document;
- (c) Nature of enquiry;
- (d) *Electrical contractor's* number and return address details (if applicable).

If the installation has not been connected to supply a reply will be provided within 2 working days from receipt of request.

If the installation has been connected to supply a reply will be provided within 5 working days from receipt of request. (Refer to Clause 1.6 for contact details).

1.6. Distributors Contact Details for QECMM Correspondence

Contact details for *QECMM* amendments or enquiries are:

Energex: Email customerservice@energex.com.au
Write to: Energex Limited QECMM Request
GPO Box 1461
BRISBANE Qld 4001

Ergon Energy: Email: customerservice@ergon.com.au
Write to: Ergon Energy QECMM Request
PO Box 308
ROCKHAMPTON Qld 4700

1.7. Historic Buildings and Flora with Vegetation Protection Orders

The *electrical contractor* should consult the owner if the building appears to have historical significance. Historic buildings may require the requirements of this manual be waived and/or modified for attachment of overhead services, meter positions etc.

Similarly, flora protected by a Vegetation Protection Order may require special arrangements for the erection or alteration of overhead or underground services.

Electrical contractors should contact the *distributor* before starting work (See Exceptional Circumstances above).

1.8. Revisions and alterations

Energex and *Ergon Energy* reserve the right to revise this publication. The current edition of this document is available on the *Energex* website at www.energex.com.au or the *Ergon Energy* website at www.ergon.com.au.

1.9. Drawings

The drawings have been placed in the body of the document after the section to which they are most relevant but may be referred to in more than one section.

QLD Electricity Connection and Metering Manual



Part of the Energy Queensland Group

THIS PAGE HAS BEEN DELIBERATELY LEFT BLANK

2. CUSTOMERS INSTALLATIONS

2.1. Request for Electrical Connection

An application for supply must be made to an electricity *retailer* licensed to operate in Queensland.

The *distributor* cannot energise a *customer's* installation unless:

- (a) The *customer* has a retail sales contract; and
- (b) The *retailer* has then requested the *distributor* to connect the *customer* via a *SOR* transaction; and
- (c) An *Electrical Work Request (EWR)* has been submitted.

Where possible, and to hasten completion, the *customer* should provide the *National Metering Identifier* to the *retailer*.

2.1.1 Large Customers

A *large customer* who consumes 100MWh or more per annum and requires an initial connection by the *distributor* must also arrange for the metering to be installed by an accredited *metering provider*. They must also request their initial connection via their chosen *retailer*.

To enable the connection to be completed to schedule, a *customer* will be required to advise the *distributor* of their expected annual consumption.

2.2. Request for Initial Connection, Service Alteration, Metering Change or Inverter change

Electrical Contractors shall submit an *Electrical Work Request (EWR)* when they:

- (a) Require an initial supply at an installation; or
- (b) Require service alterations.

Where alterations to an installation are to be carried out, the *distributor* shall be advised of any of the following situations:

- (a) Where the electricity service may be over or in the vicinity of a swimming pool or hazardous area as defined in AS/NZS 3000 (Wiring Rules);
- (b) Any proposal for new or additions to an existing HV installation (i.e. the *connection point* and or the metering transformer may need upgrading).

For major changes or load increases the *customer*, or their *electrical contractor* or consultant, should contact the *distributor* at the earliest opportunity to obtain an estimate of the time that may be required to modify the network to accommodate the changes or load increases; or

- (c) Complete work that requires additional metering or a change to existing metering when the *distributor* is the *metering provider*; or
- (d) Complete work that requires additional load control equipment or a change to existing load control equipment; or
- (e) Require MEGU Inverter additions, upgrades or replacement.

Within the *Ergon Energy* distribution area, an *EWR* (Form A) must be submitted when there is an upgrade or replacement of an existing *MEGU* inverter, or when an inverter is added to an existing inverter. A new meter will not be required but normal system compliance checking is still required.

A new application must be lodged for any inverter change or addition within both the *Ergon Energy* and *Energex* distribution areas and also for solar panel changes within the *Ergon Energy* distribution area. (Refer to Clause 8.2).

2.3. Alterations and Additions

The *electrical contractor* shall submit an *Electrical Work Request (EWR)* in adequate time for the modification to the *distributor's* service and or network to be completed before supply is required.

Examples of alterations and/or additions to the *customer* electrical installation that require submission of an *EWR* may include:

- (a) The installation of additional phase/s;
- (b) The relocation of the *connection point*;
- (c) Any increase in loading that requires an increase in the capacity of the service or distribution network;
- (d) The installation of a service following repair works (e.g. repair works after storm damage).

Note: *Customers* with a *NMI* classification - Large, are to provide the contact details of their *metering provider*.

2.4. Breaking of Metering Terminal Cover/Metering Isolation Link/Metering Neutral Link Seals

In the interests of electrical safety and to ensure the integrity of metering and *network devices* the *metering provider* and/or the *distributor* will seal this equipment.

Approval will be given for the metering terminal cover/metering isolation link/metering neutral link seals only, to be removed by an *electrical contractor* provided notification is given to the *distributor* or the *metering provider* either before the removal of the seals or as soon as practicable after the event.

An *Electrical Work Request (EWR)* must be submitted to the *distributor* as soon as possible after metering alterations are completed.

Within the *Ergon Energy* distribution area, notification of broken seals (for Receiver bridging only) can be done via a phone call to the National Contact Centre.

Where the metering terminal cover has been damaged or alterations to the metering cable entry point allows contact with live parts, the *electrical contractor* shall leave the installation in a safe state (e.g. fill/cover holes with a suitable material) and submit an *EWR* that advises a

new metering terminal cover is required. Alterations to metering terminal covers are not permitted.

Note: For remotely read interval meter installations, the *customer* is to provide the contact details of their *metering provider*. The nominated *metering provider* is responsible to ensure the metering installation complies with the requirements of Chapter 7, of the *National Electricity Rules* and this document where applicable.

2.5. Examination, Test and Connection

The *distributor's* electricity connection officer is required to examine and test the *consumer's* *mains* and main switchboard of an installation before the initial connection to supply (up to the load side of the Metering Isolation Link and Metering Neutral Link).

The examination, test, and connection shall **not be regarded as implying compliance** with any specification and the *electrical contractor* remains responsible for the standard of the work, regardless of whether an officer from the *distributor* examines, or tests, the whole or part of the installation.

2.6. Unmetered Supplies

Unmetered supply may be available where the *distributor* considers it impractical to read or maintain metering equipment or where metering equipment would be susceptible to damage. Approval must be obtained from the *distributor* prior to the installation of an *unmetered supply*. Where the *distributor* consents to an *unmetered supply* (e.g. telephone cabinet, bus shelter, traffic signals, etc.) the following general conditions will apply:

- (a) Approval must be gained (as appropriate) from any relevant authority for equipment installed in the road reserve. (Refer to the *Electricity Regulation 2006*);
- (b) The *distributor* must be advised prior to any changes to the loading of the installation;
- (c) Socket outlets are not permitted;
- (d) The installation shall consist of a small steady uniform load. (Refer to Clause 5.9(a) for installation of *consumer's mains* on the *distributor's* pole).

2.7. Identification in Multiple Installations

Each individually metered section of a multiple installation shall be clearly identifiable (e.g. shop, unit or factory number). The number shall be permanently marked on the main switchboard, distribution board (if applicable), meter, isolator and front door of the individual shop/unit so that the *distributor* may install the required connection for the installation. A site plan of the overall layout of the site shall also be permanently displayed on the inside door of the main switchboard.

An electrical test must be carried out to ensure that the meter wiring does supply that particular part of the installation that is identified by the switchboard and unit marking. This is required to confirm the relationship between the national metering identifier (NMI), the meter number/s and the address are correct.

2.8. Protective Fault Current Devices

Protective devices installed by the *customer* shall have an interrupting capacity adequate for the prospective short circuit current at the point of installation.

In the event of the fault current being increased at any point on an installation because of provisions for additional load, the *customer* shall be responsible for the upgrading of all equipment not rated for the prospective fault level.

Prospective fault level details may be obtained by contacting the *distributor*. (Refer to page 1 for contact details).

Notes:

1. The *distributor's* (HRC) low voltage service fuse rated up to 100A will provide suitable fault current limiting for a *customer's* installation. Refer to Clause 6.6.1.3 for additional meter protection requirements.
2. For low voltage supplies the *distributor's* service fuse shall not be considered as overload protection for the *consumer's* mains.
3. Installation of fault current limiters may be required to protect *direct connected metering* on the *customer's* installation. (Refer to Clause 6.6.1).

Information on high fault currents can be found in the Electrical Safety Office - Code of Practice for Electrical Work and the Electrical Safety Office web site.

2.9. Power Factor

The *distributor* requires a *customer* to ensure that the power factor of any electrical installation measured at the *consumer's* terminals under normal load conditions is not less than 0.8 lagging as set out in the *Electricity Regulation 2006* for installations supplied at low voltage. The requirement of the *National Electricity Rules* Schedule 5.3 shall be followed for other connections. (Refer to TABLE 2.1).

Unless special arrangements are made to maintain the installation's power factor at not less than 0.8 all discharge lighting in excess of 240W total tube rating shall be corrected to 0.8 pf. Except by agreement with the *distributor* the power factor of any installation shall not be leading.

If the power factor falls outside these limits, the *customer* will be responsible for taking action to ensure compliance (as agreed with the *distributor*).

TABLE 2.1 provides the power factor performance standard.

TABLE 2.1

POWER FACTOR PERFORMANCE STANDARD	
Nominal Supply Voltage	Power Factor Range
50kV - 250kV	0.95 lagging to unity
1kV <50kV	0.90 lagging to 0.90 leading
<1kV*	>0.8 lagging but not leading
* <i>Electricity Regulation 2006</i> . At all other voltage ranges the requirements are as specified by the <i>National Electricity Rules</i> , unless detailed in a contract.	

Customers shall ensure that shunt capacitors installed for power factor correction are designed to avoid attenuating the *distributor's* audio-frequency signals used for load control. The *distributor* will supply the details of the audio-frequency signals in any region upon request. *Customers* are also required to meet the harmonic emission limits specified for their installation even under resonant conditions due to their capacitor bank.

2.10. Limitations on Starting Currents of AC Motors

2.10.1 General Requirements

Except as required by Clause 2.10.4 motor installations and any associated starting devices shall be so designed and operated as to comply with either of the following conditions:

Single Phase Motors 240 Volts and 480 Volts

TABLE 2.2

MOTOR VOLTAGE	MOTOR SIZE	ALLOWABLE STARTING CURRENT
240V	All Sizes	$I = 45$ Amps
480V	Not exceeding 7.5kW	$I = (17.5 \times k)$ Amps, where k is the continuous output rating (kW) of the motor.
	Exceeding 7.5kW	Shall not be connected.

Note: The *distributor* must be contacted before motors are installed in SWER areas of supply. (Refer to page 1 for contact details).

Three Phase Motors 415 Volts

TABLE 2.3

MOTOR SIZE	ALLOWABLE STARTING CURRENT
Not exceeding 1.5kW	$I = 26$ Amps
Exceeding 1.5kW and up to 3.75kW	$I = (kW \times 17.5)$ Amps
Exceeding 3.75kW and up to 10kW	$I = (53 + 3.3 \times k)$ Amps, where k is the continuous rating, (kW) of the largest motor in the installation.
Exceeding 10kW	Contact <i>distributor</i> .

Exception:

1. No limitation may be placed on the starting current of any motor that is not frequently started and the rated output does not exceed 10% of the total motor load connected for a *customer* to the one service.
2. In *premises* which are supplied directly from a substation or in other appropriate supply conditions as determined by the *distributor*, starting currents in excess of those laid down may be permitted provided that written approval is obtained from the *distributor*. (Refer to page 1 for contact details).

Note: Motors should not be started simultaneously and the starting current of the motors should be limited to 2 to 3 times full rated current by fitting with an appropriate starter.

2.10.2 Fall in Voltage

The starting current shall not cause a fall in Voltage of more than 5% of the nominal voltage at the *connection point* for more than 0.02 seconds when connected to a typical 415/240V, 3 phase, 50Hz supply system which for this purpose shall be considered to have the following impedance:

$$Z = 0.2 + j0.2 \text{ ohms (phase - neutral);}$$

$Z = 0.1 + j0.1$ ohms (line impedance per phase).

2.10.3 Test Methods

- (a) Fall in Voltage shall be measured by instrumentation with a high-speed measurement capability.
- (b) Starting currents shall be measured by instrumentation with a high-speed measurement capability or by the locked rotor method, with the rated voltage and frequency applied to the terminals of the motor.
- (c) In any case where the test methods specified in paragraphs (a) and (b) above cannot conveniently be applied, another test method that conforms to recognised practices in the electrical industry may be used.

Note: The *distributor* will accept test results from a recognised testing laboratory or manufacturer's certified test results.

2.10.4 Special Provisions

For both three phase and single phase motors the *distributor* may require maximum starting currents lower than those set out or may limit the rating of any motor to be connected if such lower starting currents or limits of motor capacity are necessary to prevent interference with supply to other *customers*.

For isolated generation areas within the *Ergon Energy* distribution area, special limitations may be applied on starting currents of electric motors (including air conditioners) and also may require time delay controls on motor starting circuits after a power outage. Any special requirements are outlined in the *Ergon Energy* document PW000202R114 - "Guidelines for Electrical Installations at Isolated Systems" which is available on request by contacting *Ergon Energy Customer Service*. (Refer to page 1 for contact details).

2.11. Interference with Supply of Electricity to Other Customers

Customers shall take reasonable precautions to prevent transformer arc welding machines, motor starting, fluorescent lighting, Micro Embedded Generation and any other equipment from interfering with the satisfactory operation of the *distributor's* network or other *customers* systems etc.

The requirements of AS/NZS 61000 series standards "Electromagnetic Compatibility (EMC)" shall be observed at all times.

The fact that the *distributor* may have connected the apparatus or equipment causing the interference shall not exempt the *customer* from this requirement. Also see Clauses 4.2 to 4.6.

Note: *Customers* with an electrical installation or equipment which may be sensitive to voltage variation, transients, loss of one or more phases of supply or due to leakage current are advised to install protective equipment to limit possible damage.

2.12. High Voltage Installations

Any person intending to install high voltage equipment at a *premise* shall consult the *distributor* before taking steps to obtain or install such equipment.

Where the *distributor* agrees, subject to certain conditions, (such as a minimum demand being met), with a *customer's* request for a high voltage connection, the agreed voltage is the standard voltage for the supply. (Refer to the *Electricity Regulation 2006* for standard voltages). The *distributor* will provide a letter of offer or connection agreement.

The *Electrical Safety Act 2002* requires all new or altered high voltage electrical installations to be inspected by an *Accredited Auditor* before connection to supply. For additional

information on *Accredited Auditors* contact the Electrical Safety Office. The auditor should be involved in the project at an early stage.

More information in relation to HV installations is included in Chapter 9 of this manual

2.13. Customer's Generating Plant

2.13.1 General

The installation of *customer's* generating plant shall comply with AS/NZS 3000 (Wiring Rules). The *consumer's mains* neutral shall not be switched or broken on the distribution supply side of the MEN connection. The Generator neutral is required to be clearly identified at the main neutral link.

2.13.2 Non-Parallel Operation with *Distributors* Supply

Customer's generating plant for emergency supply

This section applies for the installation of generating plant on a *customer's premises* to provide a supply of electricity to the *customer's* electrical installation, during an interruption of the supply of electricity.

- (a) The *customer* shall ensure that, when the plant is operating to give emergency supply, it is installed with effective isolation between—
 - (i) all active conductors of the part of the electrical installation or electrical installations to which the plant is connected; and
 - (ii) the part of the electrical installation still connected to the supply from the *distributor*.
- (b) The connection of the plant shall be so arranged that the *metering provider's* revenue meters do not meter the alternate supply and all metering equipment, including CTs are able to be isolated to enable access whilst the generator is in service (i.e. the changeover switch must be installed on the load side of the meter).

2.13.3 Parallel Operation with *Distributor's* Supply (Co-Generation)

Customer's generating plant for interconnection to supply network

- (a) A *customer* shall not install generating plant for interconnection with the *distributor's* supply network without prior agreement.
- (b) The agreement shall include the conditions for securing safe and stable parallel operation of the supply network and the generating plant.

Note: Co-generation is allowable from all forms of alternative energy supplies such as solar panel (photovoltaic), wind turbine, diesel generation etc.

Refer to Section 8 for details of the metering schemes for interconnection of *Micro Embedded Generating Units (MEGU)* connected to the distribution network.

For generation units other than *MEGU*, the *customer* shall contact the *distributor* or the *metering provider* for specific connection requirements. Appropriate revenue metering will be installed in accordance with the negotiated supply arrangements.

2.14. Determination of Maximum Demand

Unless limited by a fixed setting circuit breaker, the determination of the maximum demand of an installation shall be calculated, measured or assessed in accordance with the guidelines given in AS/NZS 3000 (Wiring Rules).

2.15. Requirement for Circuit Breakers in Rural/Isolated Areas

The *distributor* requires circuit breaker/s for main switch/s as part of the *customer's* installation and these circuit breaker/s are required to coordinate with the service fuse/circuit breaker. The *distributor* may require the *customer's* protective device to be changed or altered to provide adequate discrimination. *Electricity Regulation 2006, sections 29 and 30.*

Notes:

1. These regulations refer to the *customer* owned circuit breaker main switch/s provided as part of the *customer's* installation and not to the *customer's* sub-circuit protection or the *distributor's* service fuse/circuit breaker.
2. Refer to Glossary of Terms for definition of *rural/isolated area*.

3. DETERMINATION OF THE NUMBER OF PHASES TO BE INSTALLED

3.1. General

The number of phases provided to supply load at an installation shall be the number required by Section 4 for individual apparatus or the number determined by this section, whichever is the greater.

Note: The *electrical contractor* or designer should consult with the *customer* to determine future loading requirements. Provision for additional phases or larger *consumer's mains* may be required (e.g. air conditioning load, MEGU, EVSE).

3.2. Urban Areas

3.2.1 Single Customer Installations

Other than where multi-phase appliances are installed on the *premises*, if the maximum demand as calculated in accordance with AS/NZS 3000 (Wiring Rules) is:

- (a) not greater than 80A, then supply shall be one phase and neutral;
- (b) between 80 and 140A, then supply shall be two phases and neutral;
- (c) greater than 140A, then supply shall be three phases and neutral.

The *distributor* approves the use of 3 phase underground or overhead supply where 3 phase load (e.g. air conditioner or pump) is connected and the remainder of the installation is balanced across the 3 phases.

3.2.2 Multi Customer Installations

Other than where multi-phase appliances are installed on the *premises* the number of phases shall be determined by the following methods:

- (a) A maximum of two individually metered units may be connected to a single phase supply if the maximum demand calculated in accordance with AS/NZS 3000 (Wiring Rules) does not exceed 70A.
- (b) Where there are more than two individually metered units, the installation shall be arranged for a three phase supply (e.g. three units - one per phase) unless otherwise advised by the *distributor*.

Note: Separate services and meter positions shall be installed for a duplex (two units divided by a common wall) where each portion has a separate (freehold) title. (Refer also to Clause 6.11.5 for Community Title Scheme arrangements).

3.3. Non-Urban Areas

In non-urban areas connection of additional phases to the *customer's* electrical installation may be necessary even though not required under the guidelines given in Clause 3.2.

Notes:

1. Where single phase 11kV only is available the maximum demand may be increased up to 100A depending on the capacity of the local transformer and supporting high voltage infrastructure.
2. Load limitations may apply for single wire earth return (SWER) systems.

For electrical installations in these areas *electrical contractors* should consult the *distributor*. (Refer to page 1 for contact details).

QLD Electricity Connection and Metering Manual



Part of the Energy Queensland Group

THIS PAGE HAS BEEN DELIBERATELY LEFT BLANK

4. BALANCING OF LOAD AND LIMITATION ON EQUIPMENT

4.1. General

The load of an installation (including all primary and secondary tariff loads), or separately metered portion of an installation supplied by separate *consumer's mains* or submains, shall be so balanced that at the time of maximum demand on such installation or portion of such installation the current in any phase does not exceed the current in any other phase by more than 20A or 20% whichever is the greater (unless otherwise approved in writing by the *distributor*). The principal tariff load (and secondary tariff load where possible) shall be balanced across all supplied phases and the use of controlled or time of use tariffs to balance another tariff across phases will not be accepted.

The *distributor* may apply additional conditions when large loads are connected in rural (non-urban) areas.

4.2. Connection of Equipment - Current Limitations

Equipment (not specified elsewhere in this part, or a lighting installation or a sign) designed to operate at 240V and whose rating is:

- (a) Not greater than 25A will be connected between one phase and neutral.
 - (i) In exceptional circumstances the *distributor* may approve the connection of single phase appliances rated at more than 25A; and
 - (ii) In multiphase electrical installations the equipment may, with the approval of the *distributor*, be connected to more than one phase and neutral provided the load of the installation is to be balanced across the supply phases.
- (b) Greater than 25A, but not greater than 50A, shall be connected between two phases and neutral, except that in multiphase electrical installations the equipment may, with the approval of the *distributor* be connected to more than two phases and neutral.
- (c) Greater than 50A, shall be connected to three phases and neutral.

4.2.1 Domestic Ranges

Urban Areas

Where an individually metered installation includes a cooking range or ranges, a total rating not exceeding 13kW may be connected to one phase and neutral.

If the total rating exceeds 13kW then:

- (a) For one range it shall be connected to at least two phases and neutral; or
- (b) For two or more ranges each range may be connected to one phase and neutral of a multiphase supply.

Non-Urban Areas

Where in accordance with Clause 3.2 an electrical installation is required to be connected to either two phase and neutral, or three phase and neutral, all ranges should be balanced over the number of phases connected.

4.2.2 Commercial Cooking Appliances

Any such appliance, whose total rating at 240V is:

- (a) Not greater than 35A, shall be connected to one phase and neutral; or
- (b) Greater than 35A, shall be connected to a minimum of two phases and neutral.

4.2.3 Water Heaters

- (a) Instantaneous water heater systems

I. Residential

The rated current of an instantaneous water heater shall not exceed 40A (total load) for a three phase system or 20A for a single phase system in a residential building, unless otherwise approved in writing by the *distributor*.

II. Commercial/Industrial

The rated current of an instantaneous water heater shall not exceed 40A (total load) for a three phase system or 40A for a single phase system (Energex only) or 20A for a single phase system (Ergon Energy only) in a commercial or industrial building, unless otherwise approved in writing by the *distributor*.

- (b) For the suitability of water heaters for controlled or night rate supplies reference should be made to the Network Tariff Guide (available from the distributor's web site) e.g. where the heating unit rating exceeds 1800W, it shall not exceed 13.5W per litre of heat storage volume for heat exchange type water heaters or 15.5W per litre of rated hot water delivery for other storage type water heaters.

4.2.4 Kilns in Domestic Installations

A kiln, which has a total rating not exceeding 30A, shall be connected to one phase and neutral in domestic installations.

A kiln with a total rating exceeding 30A shall be connected to two or more phases and balanced over the number of phases connected to the installation.

4.2.5 Electric Vehicle Supply Equipment

Electric vehicle supply equipment shall be compliant with AS/IEC 62196.

I. Residential

The rated current of the *EVSE* shall not exceed 40A (total load) for a three phase system or 20A for a single phase system in a residential building, unless otherwise approved in writing by the *distributor*.

II. Commercial/Industrial

The rated current of the *EVSE* shall not exceed 40A (total load) for a three phase system or 40A for a single phase system (*Energex* only) or 20A for a single phase system (*Ergon Energy* only) in a commercial or industrial building, unless otherwise approved in writing by the *distributor*.

4.3. Equipment Having Fluctuating Loads.

Examples of equipment having fluctuating loads are: Welding Machines, X-Ray equipment, furnaces etc.

The *distributor* reserves the right to specify the conditions under which an electricity supply will be given for equipment having rapidly fluctuating loads such as welding machines (other than welding machines complying with AS 60974.6, or previous standards superseded by this standard, and marked "Limited Input"), X-ray equipment and furnaces.

No work should be carried out by a *customer* until advice has been received on the terms on which supply will be given. (Refer to Clause 2.11 "Interference with Supply of Electricity to Other Customers").

4.4. Harmonic Interference or Wave Form Distortion

The *distributor* reserves the right to specify the conditions under which an electricity supply will be given for equipment which would cause excessive distortion to the wave form of the

supply system voltage. (e.g. rectifiers, frequency converters, load control devices using thyristors or saturable reactors).

4.5. Rectifiers

Alternating to direct current rectifying equipment shall not be connected to the *distributor's* system unless:

- (a) The rectifier is of the full-wave type; or
- (b) A double-wound transformer is interposed between the rectifier and the supply system; or
- (c) The rectifier is used in conjunction with an electrical measuring instrument or in similar applications where the rectified current does not exceed 100mA.

Note: Further information regarding general limits may be obtained from AS/NZS 61000 series "Electromagnetic Compatibility (EMC)".

Additional limits apply to avoid harmonic interference to the *distributor's* audio frequency load control system. (Refer to Clause 2.9).

4.6. Connection of Equipment - Voltage Limitations

All equipment must be able to operate satisfactorily within the voltage limits detailed in the current Queensland Electricity Legislation.

4.7. Connection of Equipment - Isolated Generation Localities

Load restrictions on electric motors, welders, air conditioners and other electrical equipment in excess of 2.4kW may apply in isolated remote generation areas throughout *Ergon Energy*. Call Customer Service (refer page 1) to clarify any restrictions contained in *Ergon Energy* document PW000202R114 - "Guidelines for Electrical Installations at Isolated Systems".

QLD Electricity Connection and Metering Manual



Part of the Energy Queensland Group

THIS PAGE HAS BEEN DELIBERATELY LEFT BLANK

5. SERVICE LINES AND CONNECTION POINT

5.1. General

Each individual electrical installation (as defined in AS/NZS 3000 (Wiring Rules)) shall have a separate and individual connection to the supply network (i.e. Separate *connection point - service line, point of attachment, consumer's mains* etc).

Note: The *distributor* will not accept any "Joint Use" arrangements where two or more *customers* share the same property pole and/or property line and/or overhead service (e.g. small lot subdivisions).

5.2. Connection point (Consumer's Terminals)

Unless otherwise determined or approved by the *distributor*, the *connection point* shall be located as detailed in Clauses 5.2.1 and 5.2.2.

5.2.1 Low Voltage

The *connection point* shall be located -

- (a) at the termination of the overhead *service line* onto a building or structure where the *service line* is installed without the use of property poles (i.e. typically the first span of *service line* to the first structure); or
- (b) on the first property pole (termination pole) from the point of origin of the *service line* where supply is connected by means of a property line.

Unless otherwise approved by the *distributor*, the termination pole shall not be located more than 20m from the property boundary. Where the *service line* does not cross a property boundary the first property pole shall not be located more than 20m from the origin of the *service line*.

In the case where the *service line* crosses a road reserve and extends into private property, the total length of the *service line* from the *distributor's* supply pole to the first property pole shall not exceed 50m; or

Note: To comply with this requirement, the distance that the first property pole is located within the property may need to be reduced so that the 50m limit of the *service line* is not exceeded (in special situations the service length may be increased at the discretion of the *distributor*).

- (c) in a service pillar or pit at the *customer's* property boundary in underground residential distribution areas and non - CBD commercial and industrial areas; or
- (d) at the termination of the underground *service line* on the *customer's premises*. This arrangement is generally restricted to the CBD; or
- (e) at the low voltage terminals of a distribution transformer installed at the *customer's premises* or at the load terminals of any switch or circuit protective device that may be installed by the *distributor* at such transformer. (Refer to Clause 5.10 "Substations on *Customer's Premises*").

5.2.2 High Voltage

The *connection point* shall be as determined by the *distributor* and documented in the connection agreement.

5.3. Service Lines

5.3.1 Working on or near the Distributor's Assets

It is the responsibility of the *electrical contractor* to obtain permission to work on or near the *distributor's* assets. (*Electrical Safety Regulation 2013*). Examples where

authorisation is required include, work on or near the *point of attachment*, accessing standard underground pillars or work at the low voltage end of a distribution transformer. Information on the requirements for becoming an authorised person can be obtained from the *distributor's* call centre. (Refer to page 1 for contact details).

5.3.2 General

Unless otherwise advised, the *distributor* will provide either an overhead *service line* or an underground *connection point* (typically an underground service pillar). For further details on each *service line* type refer to Clauses 5.4 and 5.5.

For *service lines* in general:

- (a) A charge may be made by the *distributor* for the installation and removal of a temporary *service line*.
- (b) A charge may be made by the *distributor* for any additional *service line* or additional phases for hobby or other purposes.
- (c) Where a *customer* requests that a type of *service line*, other than that proposed by the *distributor*, be installed and the *distributor* agrees to install such type of *service line*, the *customer* shall be required to pay additional costs in line with the Connection policy.
- (d) Where a *customer* requests that an existing *service line* be altered, and the *distributor* agrees to make such alteration, the *customer* shall be required to pay all costs.
- (e) Where the *customer* requests an alternate point of origin for a *service line*, a capital contribution may be required for any extension of the *distributor's* mains.
- (f) The *customer* shall ensure sufficient clear unobstructed access to, around, and below the *point of attachment* and *connection point* to allow the *distributor* to safely maintain the service. Note requirements of Clause 5.4 below.
- (g) The *customer* via their *electrical contractor* is required to provide the means of connection for either an underground or overhead connection, e.g. a *suitable mains connection box* or suitably sized enclosure with insulating shrouds to suit, complete with 12mm stainless steel bolts, nuts, washers and spring washers. The *electrical contractor* shall lug the conductors. Where aluminium cable is used for underground *consumer's mains*, cable ends are required to be terminated with suitable bi-metallic connectors, for connection to fuses and neutral link.

5.4. Overhead Service Lines

The *distributor* shall determine the point of origin, the route, the *point of attachment* and the facilities required for the attachment and connection of the *service line*. NOTE: This may include provision of a *customer* Property Pole as a suitable point of attachment, (Refer to Clause 5.4.2 for requirements). A direct line service is always the preferred option i.e. direct from the appropriate network distribution pole to the *customer's* first *point of attachment*. The *customer* or their *electrical contractor* shall consult the *distributor* prior to planning the installation. (Refer to service clearance details in Drawings QECMM 5.1 and 5.2).

The *distributor* will not erect or connect a *service line* that crosses an adjacent property or premises.

Only a person authorised by the *distributor*, shall install and connect an overhead *service line* to the *customer's* installation.

The *distributor* shall determine the type of overhead *service line* and shall supply, install and maintain the *service line* at its own cost (the *service line* will be installed from the *distributor's* works to the *connection point*), except that:

- (a) Where the service is a Standard Control Service and the *distributor* has agreed to an overhead *service line* in excess of 20m (either low or high voltage) the *customer* may be charged for all costs of the length of *service line* in excess of 20m. This distance is measured from the point where it crosses the *customer's* property alignment, or where such *service line* does not cross the property alignment, in excess of 20m from the point of origin of the *service line*. The contribution to be made by the *customer* is to be calculated in line with the *Connection policy*.
- (b) All poles or other structures on the *customer's premises* for the attachment of an overhead *service line* and overhead *consumer's mains* shall be provided and maintained by the *customer*.
- (c) The *distributor* will not erect an overhead *service line* at any height over a hazardous area or pool zone as defined in AS/NZS 3000 (Wiring Rules). (Refer to Drawing QECMM 6.4)
- (d) A *customer* shall provide suitable facilities on their *premises*, acceptable to the *distributor* for the attachment and connection of a *service line*. This may require the *customer* to install a property pole.
- (e) A *customer* must ensure that the route for a new overhead *service line* is cleared of trees and other flora that may contact the line and that the line clearances remain unaffected by subsequent works on the *premises*. (e.g. building alterations, land fill, driveways, trafficable areas, changes in landscape etc).
- (f) Overhead conductors after the *connection point* are the responsibility of the *customer*.
- (g) Flying fox services are at the discretion of the *distributor* and prior written approval is mandatory.

Prior approval for a flying fox service arrangement is essential; the *distributor* will not approve any flying fox arrangement without prior consultation.

Additional costs associated with the flying fox service connection (refer 5.3.2 (c) and (d)) will be payable in full prior to connection.

Note: Details of overhead services line clearances are shown in Drawings QECMM 5.1 and 5.2.

5.4.1 Cross Road Service Poles

The *distributor* shall only install cross road service poles:

- (a) Where required to maintain statutory clearances across the roadway; and
- (b) Where no property pole would be required if the *distributor's* mains poles were erected on the same side of the road as the property (consultation with the *distributor* required).

5.4.2 Property Poles

- (a) Precautions must be taken to prevent both internal and external corrosion in steel property poles. Due to the difficulties of assessing the extent of internal corrosion of steel in ground poles a rag bolt assembly is mandatory where a steel pole is used for the first property pole. Refer to Drawings QECMM 5.3, 5.5 and 5.6 for a 1.0kN SWL design or 5.4, 5.7 and 5.8 for a 3.5kN SWL design. Note that these drawings have prior *RPEQ* certification and if this design is

used exactly as detailed in the drawings then additional *RPEQ* certification is not required. If ANY modification is made to this design (including simple welding of attachments) then *RPEQ* certification is required for that modification hence *electrical contractors* should not be making on-site modifications without obtaining *RPEQ* sign off. Similarly pole manufacturers should not change the design of the drawings without obtaining *RPEQ* sign off. These drawings are not mandatory but provided as an example of an approved design. *Electrical contractors* can use other designs but must have *RPEQ* certification and provide a copy of the *RPEQ* certificate with the pole for approval by the *distributor* connection officer prior to connecting supply.

For Builder's Temporary Supply (BTS), where a steel reusable pole is used, refer to Drawings QECMM 5.9, 5.10 and 5.11 for details of an approved design. The connection of the overhead *service line* can be facilitated with the use of a mains connection box suitable for copper conductors.

The *point of attachment* is to be mounted within 600mm from the top of the pole (however this distance can be increased to ensure the point of attachment is no higher than 8m from the ground) and the *connection point* is to be as per Clause 5.4.5 (a).

- (b) Timber property poles are to be suitably treated and have a minimum SWL rating of 5kN (as indicated on the pole disc). Other types of timber property poles are acceptable provided they meet the requirements of AS/NZS 3000 (Wiring Rules) Appendix D.

Within the *Ergon Energy* distribution area it is required that all *customer* property poles be a minimum of 5.0m out of the ground.

- (c) Other types of property poles are acceptable that have an *RPEQ* certificate and are rated fit for use i.e. (1kN, 3.5kN or 7kN) and must also comply with Clause 5.4.6.
- (d) Private equipment can be installed on a property pole. The private equipment must not be located above the *service line*, shall be at least 1.2m below the *point of attachment* (does not include *consumer's mains/sub mains*) and must be in a position that does not limit access to the *point of attachment*.

5.4.3 Overhead Service Line Attachments

- (a) Standard service cables used are XLPE insulated aluminium in sizes 25mm², 35mm² (*Energex* only), 50mm² (*Ergon Energy* only) and 95mm². Paralleling of 25mm², 35mm² (*Energex* only) and 50mm² (*Ergon Energy* Only) is not allowed for residential connections. Paralleling of 95mm² is allowed for a commercial/industrial connection but is not the preferred arrangement. The preferred arrangement is 240mm² Al 4 core underground cables with a Commercial & Industrial pillar as the connection point. A 6mm² copper *service line* may be used for small *unmetered supplies* such as telephone cabinets etc.
- (b) The following safe working loads (SWL) apply:
 - (i) Attachments for 25mm² and 35mm² (*Energex* only) overhead *service lines* shall have a load rating of 1kN working load. (Refer to Drawing QECMM 5.12).
 - (ii) 50mm² (*Ergon Energy* only) and 95mm² services shall have a load rating of 3.5kN working load and parallel (twin) 95mm² overhead *service lines* (refer

above condition) shall have a load rating of 7kN working load. Safe working loads shall be determined by applying a factor of 2 to failing loads.

For overhead *service lines* requiring a 3.5kN design for the eye bolt, raiser bracket or service pole, (other than hardwood timber which requires 5kN), the *customer* must provide certification from a suitably qualified person (i.e. an *RPEQ*) that the structure is suitable for the application. (Refer to Drawing QECMM 5.15).

- (c) The method of attachment of an overhead *service line* to a structure shall be such that mechanical load is transmitted to the frame of the structure. Details of approved attachment details for 1kN and 3.5kN service attachments are contained in Drawings QECMM 5.12; 5.13; 5.14 and 5.15.
- (d) 'J' Hooks are not permitted on fascias or poles. For 1kN services a minimum M12 open eye screw or eye bolt is acceptable. For other services up to 3.5kN a minimum M16 eye bolt is required
- (e) Where any electric line or electrical article of a *customer's* electrical installation is to be supported by any structure, other than a wooden or steel pole conforming to the requirements of AS/NZS 3000 (Wiring Rules), the *customer* must provide certification from a suitably qualified person (i.e. an *RPEQ*) that the structure is suitable for the application.
- (f) The maximum height of the *point of attachment* of any overhead *service line* on a *customer's premises* shall not exceed 8m above ground or floor level and shall have ready and safe access by ladder. This maximum height may only be exceeded in special situations where the *distributor* has approved the arrangement, and given this approval in writing.
- (g) Where raiser brackets or eyebolts are used, the design and installation is to make provision for work to be carried out safely. (Refer to the Workplace Health and Safety Legislation).
- (h) The *point of attachment* must not be positioned such that the *distributor's* personnel need to climb on roofs or enter swimming pool areas. (Refer to Drawing QECMM 6.4).

5.4.4 Raiser Brackets

Proprietary raiser brackets (not exceeding 1.2m in height), certified by an *RPEQ*, tested to a suitable SWL (e.g. 1kN or 3.5kN minimum rating for raiser brackets), and approved by *Energex* or *Ergon Energy* are deemed suitable.

Notes:

1. Within the *Ergon Energy* distribution area, the maximum size overhead *service line* that will be erected to 1kN rated brackets is 3 phase 25mm². (Refer to Clause 5.4.3(a) for 3.5kN bracket requirements).
2. Refer to Drawing QECMM 5.12 for examples of acceptable service raiser bracket designs i.e. brackets that display an SWL and are fitted with a means of attachment that will retain the service in high wind conditions (e.g. a pigtail or closed loop).
3. Where timber is used as an anchorage for 1kN raiser brackets and eye bolts it is to be a minimum of 100mm X 75mm and securely fastened to or part of the building structural frame. (A bracket mounted on a fascia without suitable bracing to the structural frame is not considered to be an effective method).
4. Through roof mounted service raiser brackets shall be positioned no further than 0.5m back from the edge of the roof or guttering.

5. All service raiser brackets shall be positioned so that any backstay attached to the roof is in line with the direction of the service pull +/- 20 degrees.
6. Where an approved side pull type service raiser bracket is installed, and the angle of the *service line* from the *point of attachment* to the *connection point* exceeds 60 degrees or is greater than that recommended by the manufacture, a service raiser bracket designed for this application shall be installed. The height of this bracket shall not exceed 1.2m.

5.4.5 Connection point Overhead Service Lines

- (a) The *connection point* shall be no more than 600mm from the *point of attachment*.
- (b) The *point of attachment* and the *connection point* are to be positioned on the building or structure where the *distributor's* personnel have unobstructed ready and safe access from the same common ladder position. That is, it must be positioned where personnel do not climb on roofs, enter adjoining properties, or carry ladders through structures, and or buildings for access.
- (c) Clear level and safe access to the *point of attachment* shall be maintained by the *customer* to allow the *distributor* to maintain the service. A clear level area below the *point of attachment* that allows a ladder ratio of 4:1 vertical to horizontal is deemed suitable.
- (d) The *customer* shall, at their expense, relocate the *point of attachment* to an acceptable position complying with Section 5 when the existing *point of attachment* is located in an unsuitable location and:
 - Electrical work is performed at an existing installation resulting in a major alteration as per clause 6.11.5 or;
 - Building works are carried out at premises that results in the requirements of clause 5.4.5 (b) or (c) not being satisfied.

5.4.6 Connection Arrangements at Connection point

- (a) A *suitable mains connection box*, complete with house service connectors, shall be provided by the *customer* for the connection of overhead *service lines* to *consumer's mains*.
- (b) *Suitable mains connection boxes* shall be mounted to provide adequate support by brackets or similar and not be reliant on rigid conduit for support. (Refer to Drawings QECMM 5.13; 5.14 and 5.15).
- (c) If *consumer's mains* are replaced or upgraded on an existing installation, a *suitable mains connection box* or an insulated enclosure shall be installed to the same standard as for a new service.
- (d) Where an overhead *service line* is to be connected to overhead *consumer's mains*, clamps suitable for this application shall be provided. This does not apply where parallel overhead *service lines* or parallel *consumer's mains* are installed.
- (e) Where the conductors of either the *service line* or *consumer's mains* are of a size not suitable for a *mains connection box*, the method of connection shall be such that the *consumer's mains* are terminated with cable lugs within a UV resistant insulated enclosure. (Refer to Note 1 below and to Drawings QECMM 5.13, 5.14 and 5.15). The *customer* (via their *electrical contractor*) is required to provide an approved UV resistant insulated enclosure and crimp lugs complete with shroud, 12mm stainless steel bolts, nuts, washers and spring washers fitted onto the *consumer's mains*.

Exception: The requirement for a *suitable mains connection box* or UV enclosure is waived where the *distributor's service line* is terminated onto aerial overhead *consumer's mains*.

TABLE 5.1 below gives the suitable sizes of UV resistant insulated enclosures:

TABLE 5.1

UV RESISTANT INSULATED ENCLOSURE	
Service Type	PVC Enclosure Size
Single 35 or 50mm ² LV ABC service	360mm X 270mm X 205mm *
Single & Parallel (Twin) 95mm ² LV ABC service	540mm X 360mm X 220mm

* Certain manufacturers utilise a spacer to achieve 220mm depth.

Notes:

1. *Suitable mains connection boxes* are available for conductors up to 95mm². Where double insulated sheathed cables are used for the *consumer's mains*, the sheathing must be removed in accordance with the manufacturer's instructions before termination into the IPC connector.
2. Refer to Clause 6.8 for phase identification requirements.
3. It is recommended that these enclosures be mounted vertically with entry of *consumer's mains* positioned low, through the bottom of the enclosure.
4. For a builder's temporary supply (BTS), that utilises a reusable steel pole, the connection of the overhead *service line* can be facilitated with the use of a *suitable mains connection box*. Refer to Drawings QECMM 5.9; 5.10 and 5.11 for details of steel BTS poles design. All BTS must be metered.

5.5. Underground Service Lines

The *distributor* shall determine the point of origin, the route and the *point of entry* of the *service line*. The *customer* or *electrical contractor* shall consult the *distributor* prior to planning the installation.

For underground *service lines*:

- (a) Where supply is by either a low voltage or a high voltage underground *service line*, the *customer* shall be charged all costs for the length of *service line* in excess of 7m from the point -
 - (i) where it crosses the *customer's* property alignment; or,
 - (ii) where such a *service line* does not cross the property alignment in excess of 7m from the point of origin of the *service line*, except as provided for in Clause 5.2.1(c).
- (b) Where required by the *distributor* for commercial or industrial installations, *customers* shall provide suitable facilities on their *premises* for the entrance, support, protection and termination of an underground *service line*. (Refer to the *Energex Commercial and Industrial Substation Manual* for details or the *Ergon Energy Indoor Distribution Substation Design Standard*).

5.5.1 Underground Pit Systems

In areas where an underground pit system has been installed (e.g. In the *Energex* distribution area at Northlakes, Inala and Runaway Bay and at various locations in the *Ergon Energy* distribution area) special requirements apply to the installation/upgrade of the *consumer mains*. (Contact the relevant *distributor* for details).

5.5.2 Underground Services in Overhead Areas

Pillars should not be installed in areas subject to regular/frequent flooding (up to 1 in 10 years). This will be defined by Local Government flood maps where available or based upon previous flood events.

Where a *customer* in an overhead service area requests the installation of an underground service, and the *distributor* agrees to the request, supply shall be taken from a service pillar or pit installed on the footpath in line with the side property boundary. This service pillar or pit will be available to provide future underground supply to the adjoining property if required. Full recovery of costs for the additional assets will apply. A typical arrangement for an underground LV service pillar is shown in FIGURE 5.1.

5.5.3 Underground Service Pillars

It is the responsibility of the *electrical contractor* to install the *consumer's mains* and conduit into the service pillar for termination by the *distributor's* personnel. (Refer to Clause 5.3.1 for access details). FIGURE 5.1 shows a typical LV service pillar arrangement.

Ergon Energy Distribution Area

In Ergon Energy a 40mm Lead In (service) conduit is provided for the Electrical Contractor to use for the installation of consumer mains. Each Lead In conduit exits the pillar at a 45 degree angle, is installed 600mm deep and is identifiable with Orange Caution Tape tied to the end of the conduit extending to ground level for ease of location. A 25mm reducer is provided on each Lead In conduit. The reducer can be removed and replaced as necessary. Consumer mains shall only be installed via the Lead In (service) conduits provided. Alternative installation of mains to the pillar without the use of the conduits supplied can result in the pillar being undermined and de-stabilised and can result in damage to the supply cables.

The route of the *consumer's mains* is to be identified in accordance with AS/NZS 3000 (Wiring Rules).

Note: To prevent damage to the *distributors* service fuse, the conduit shall not protrude past the pillar base and shall be positioned to the rear of the fuse panel. The minimum length of the *consumer's mains* shall be sufficient to reach the top of the fuse panel +300mm.

FIGURE 5.1

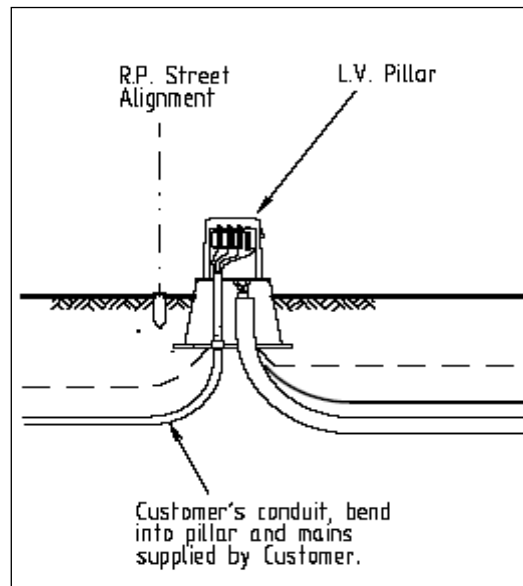

Note: Refer to Clause 6.12.1 for meter enclosure mounting requirements.

5.6. Additional Service Lines in Urban Areas

The *distributor* shall install only one *service line* to supply one building or group of buildings occupied by one *customer* on one property.

Exception: Where two or more *customers* occupy one property, supply by more than one *service line* shall be at the discretion of the *distributor*.

Where the *distributor* agrees to install an additional *service line*, the *customer* may be required to pay all costs of the second *service line*.

5.7. Additional Service Lines in Non-Urban Areas

In non-urban areas, more than one *service line* may be provided to a *customer* provided that:

- The second *service line* is a considerable distance (e.g. more than 200m) from the first *service line* measured along the *customer's* property alignment and the load to be supplied is a considerable distance (e.g. more than 100m) from any building supplied by the first *service line*;
- In the opinion, and at the discretion of the *distributor*, it is more practical to supply the load on the property through more than one *service line*.

Where the *distributor* agrees to install an additional *service line*, the *customer* may be required to pay all costs of the second *service line*.

5.8. Alterations to Service Lines

Any alteration to a *service line* shall only be made by a person authorised by the *distributor*. The *customer* may be required to pay all costs of a *service line* alteration, unless the alteration is required for the *distributor's* purposes.

Before commencing building alterations or the erection of structures in proximity to *service lines*, the *customer* or *customer's* representative shall contact the *distributor* to ensure electrical safety is not compromised. (Refer to page 1 for contact details).

5.9. Consumer's mains on the Distributor's Poles

In general, *consumer's mains* shall not be installed on the *distributor's* poles. However, approval at the discretion of the *distributor* may be given under the conditions set out in part (a) and (b) below:

(a) Unmetered Installations

Unmetered installations are generally owned by a telecommunications company, public body (or affiliated operator) or other companies (approved by a public body) and installed on public land. (Refer to Clause 2.6).

When the installation does not meet the requirements of an *unmetered supply* (e.g. council public parks) it will be treated as a metered installation.

In no case shall the maximum demand of these installations exceed the rating of a standard overhead service (i.e. 100A per phase). This arrangement generally applies only to Rate 3 Public Lighting where a standard charge per light applies.

Where the above has been satisfied, approval may be granted for the public body (or affiliated operator) or other companies (approved by a public body) to install the *consumer's mains* on poles designated by the *distributor*.

Note: Specific requirements apply (particular poles types are unsuitable). The *customer* must contact the *distributor* for details and approval.

(b) Metered Installations:

In all cases this arrangement is totally at the discretion of the *distributor* and the following criteria must be satisfied:

- (i) The supply network is within the boundaries of the *customer's* property; and
- (ii) The installation actual demand is above 400A (i.e. in excess of a standard overhead service arrangement); or
- (iii) The electrical installation is owned by a Public Body or other companies (approved by a public body) and complies with the following -
 - the installation is for the use of the general public; and
 - the installation is installed on public land; and
 - the public body or other companies (approved by a public body) is able to demonstrate that there is a community benefit in not installing a property pole (e.g. supply to parkland etc.); and
 - the *distributor's* network is within a reasonable distance from the *connection point* (i.e. not more than 20m); and
 - the network is on the same side of the road as the installation; and
 - the installation maximum demand is not greater than 100A per phase.

Note: Special conditions apply for all the above and approval, as well as the details of the requirements, must be obtained from the *distributor* prior to the commencement of any design or installation work. The *customer* shall meet all associated costs.

5.10. Substations on Customer's Premises

Where the aggregate maximum demand exceeds or is reasonably estimated to exceed 100kVA as determined by AS/NZS 3000 (Wiring Rules), the *distributor* may require a *customer* to provide free of charge the space necessary for a substation in accordance with the *Electricity Regulation 2006*.

5.10.1 Consumer's Mains Connections to Transformer Terminals

Where *consumer's mains* originate at the terminals of a transformer, they shall be adequately supported and shall be connected to the transformer terminals by flexible braid connectors and adaptor plates.

The *electrical contractor* is responsible for the supply and installation of the low voltage support stand/terminal cover, flexible braid connectors, adaptor plates and *consumer's mains*, plus any equipment required by the *distributor's* Commercial and Industrial Substation Manual. (Refer to page 1 for details).

5.10.2 Multiple Transformers

Where multiple transformers supply a single switchboard each transformer must be connected to a separate bus section, however, a bus-tie switching arrangement is permitted provided:

- (a) The bus-tie switches are fitted with fail safe interlocking devices to prevent paralleling of the supplies; and
- (b) If the bus-tie switches are a type that cannot be operated under load, fitted with a warning label to indicate the operating requirements; and
- (c) Be installed and identified in accordance with AS/NZS 3000 (Wiring Rules).

In general, where the *distributor* agrees to provide more than one connection point to an installation, the *customer* must ensure that the supplies cannot be connected in parallel.

5.10.3 Buried Earthing Systems

Provision of a high voltage substation requires the installation of buried earthing systems. These earthing systems are generally installed within 5m of the substation, however in some cases additional earthing cables may be required. These additional earthing cables would generally be located under the line and may extend some distance away from the substation. For safety reasons, it is important that building foundations, *customers'* low voltage earths or other metallic structures be located a distance of at least 5m or more away from the high voltage earthing system. The *distributor* will provide advice on the location of the earthing system for specific installations if required.

5.11. Joints in Consumer's mains

Joints in un-metered *consumer's mains* are permitted provided they comply with AS/NZS 3000 (Wiring Rules) and are not vulnerable to tampering by re-instating insulation to equivalent of an unbroken cable.

QLD Electricity Connection and Metering Manual



Part of the Energy Queensland Group

THIS PAGE HAS BEEN DELIBERATELY LEFT BLANK

OVERHEAD SERVICE CLEARANCES	OVERHEAD SERVICE CLEARANCES	OVERHEAD SERVICE CLEARANCES
<p>USE IN CONJUNCTION WITH SERVICE CLEARANCES TABLE ON DRAWING QECMM 5.2</p> <p>MAXIMUM OF 500mm TO RISER BRACKET</p>	<p>MAXIMUM OF 500mm TO RISER BRACKET</p>	<p>NO CLEARANCE LIMITS IN VICINITY OF ATTACHMENT POINTS (NOTE 2)</p> <p>* Applies from where a person is <u>LIKELY</u> to stand as determined by site risk assessment. For the purpose of service clearance determination, a person is considered <u>LIKELY TO STAND ON</u>: <ul style="list-style-type: none"> • a part of a structure that is strong enough to support a person's weight; and, • a surrounding wall or handrail where the wall or handrail is at least 200mm wide. </p>
Revision: A	OVERHEAD SERVICE CLEARANCES	QECMM - 5.1

SERVICE CLEARANCE TABLE Neutral Screened and Insulated Cables			INSULATED SERVICE CABLE
CODE	LOCATION	DIRECTION	
MINIMUM CLEARANCE FROM GROUND ROADS			
A	At centre-line of the carriageway	VERTICALLY	5.5m
B	At kerb line (bottom of kerb)	VERTICALLY	4.9m
C	At fence alignment	VERTICALLY	3.7m
OTHER THAN ROADS			
D	Private driveways and areas including elevated areas used by vehicles	VERTICALLY	4.5m
E	Areas not normally used by vehicles	VERTICALLY	2.7m
F	Road cuttings, embankments and other similar places.	HORIZONTALLY	1.5m
MINIMUM CLEARANCE FROM STRUCTURES AND BUILDINGS			
G	Unroofed terraces, balconies, sun-decks, paved areas, and similar areas that are subject to pedestrian traffic only, that have a hand rail or wall surrounding the area and on which a person is likely to stand (Note 2) must be-	VERTICALLY ABOVE VERTICALLY BELOW	2.4m 1.2m
H	Roofs or similar structures not used for traffic or resort but on which a person is likely to stand, and for parapets surrounding roofs or similar structures not used for traffic or resort but on which a person is likely to stand (Note 2) must be-	HORIZONTALLY (Note 1)	0.9m
I	Roofs or similar structures not used for traffic or resort but on which a person is likely to stand (Note 2) must be-	VERTICALLY	0.5m
J	Covered places of traffic or resort including for example windows which are capable of being opened, roofed open verandahs and covered balconies must be (Note 6)	HORIZONTALLY (Note 1)	0.2m
K	Blank walls, windows which cannot be opened (Note 2) must be-	IN ANY DIRECTION	1.2m
L	Other structures not normally accessible to persons (Note 2) must be-	HORIZONTALLY	0.2m
M		IN ANY DIRECTION	1.2m
N			

NOTES:

- Either the vertical clearance or the horizontal clearance must be maintained. Also, in the zone outside the vertical alignment of the building or structure, either the horizontal clearance from the vertical alignment, or vertical clearance above the horizontal level on which a person is likely to stand must be maintained.
- Stated clearances apply to a service line not attached to the part of the building described.
- The clearance stated does not apply to the part of the low voltage overhead service line not under tension. Drip loops are excluded however, consideration should be given to drip loop positioning. (Note: Point of supply is to be not more than 600mm from the point of attachment - POA).
- Where there is no formed footpath, the kerb line means:
 - the kerb line of a proposed footpath, or
 - where no footpath is proposed, the edge of the existing carriageway or of any proposed widening thereof.
 - where there is a formed footpath with kerb & channel, the kerb line means to the bottom of the channel.
- In situations where the eye screw of a consumer's installation is not provided with an earth tag and is in close proximity to metalwork, (eg the metalwork of a fascia) the eye screw shall be bonded to the earth tail of the house service neutral connector.
- Where a window sill is determined as not being a place a person is likely to stand (eg. hopper windows, security screened windows and sliding windows), a clearance of 2.4m vertically from floor or 1.2m horizontally shall apply
- For this table a conductor is taken to be insulated if it is insulated in accordance with AS/NZS 5000.1 (Electric cables - Polymeric insulated - For working voltage up to and including 0.6 / 1kV) or AS/NZS 3560.1 (Electric cables - Cross-linked polyethylene insulated - Aerial bundled - For working voltages up to and including 0.6 / 1 (1-2) kV). Otherwise, it is taken to be uninsulated.

QECMM - 5.2

Revision: A	SERVICE CABLE CLEARANCES FROM GROUND & STRUCTURES	QECMM - 5.2
------------------------------	--	--------------------

QLD Electricity Connection and Metering Manual



Part of the Energy Queensland Group

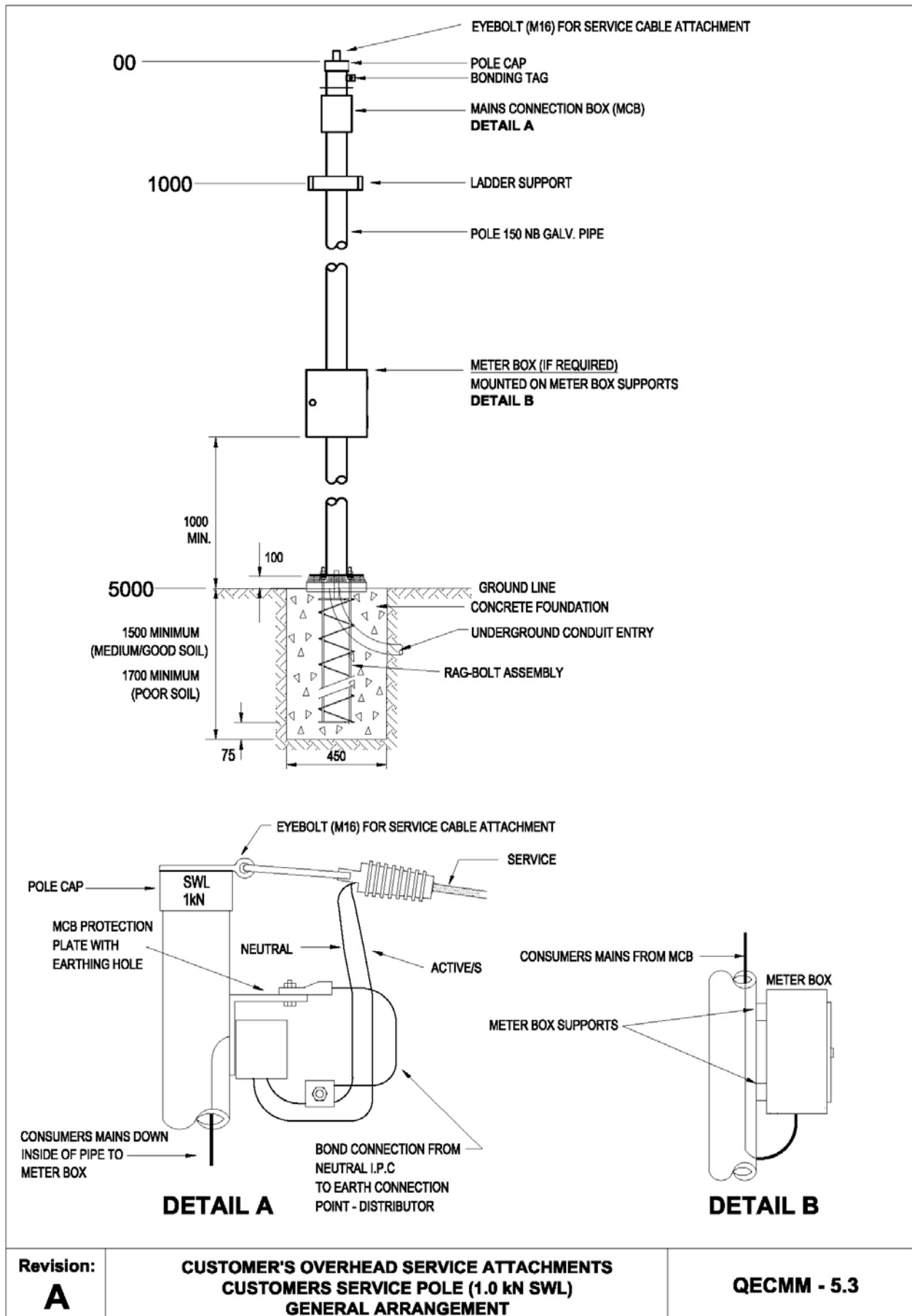

QLD Electricity Connection and Metering Manual



Part of the Energy Queensland Group

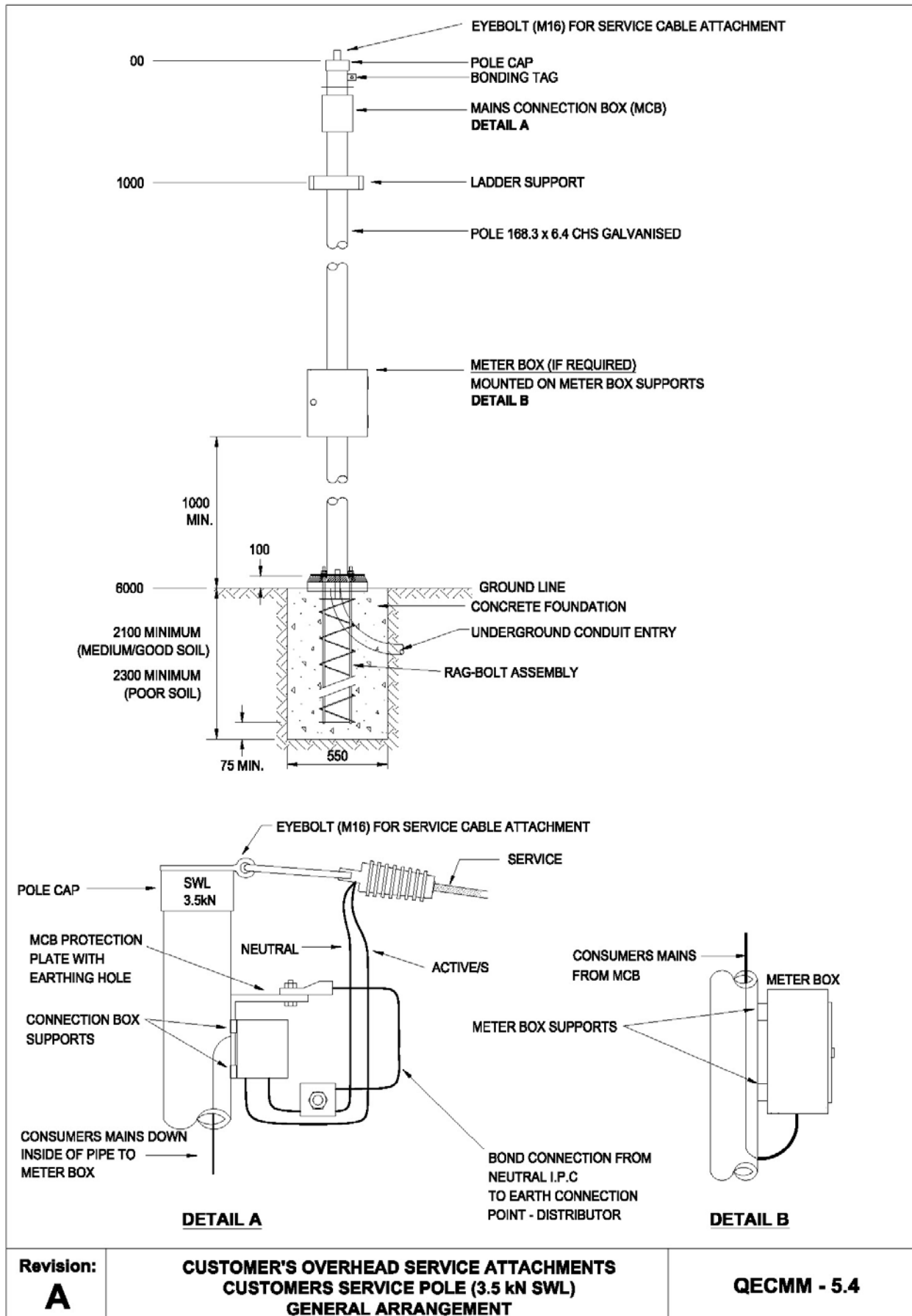

QLD Electricity Connection and Metering Manual



Part of the Energy Queensland Group

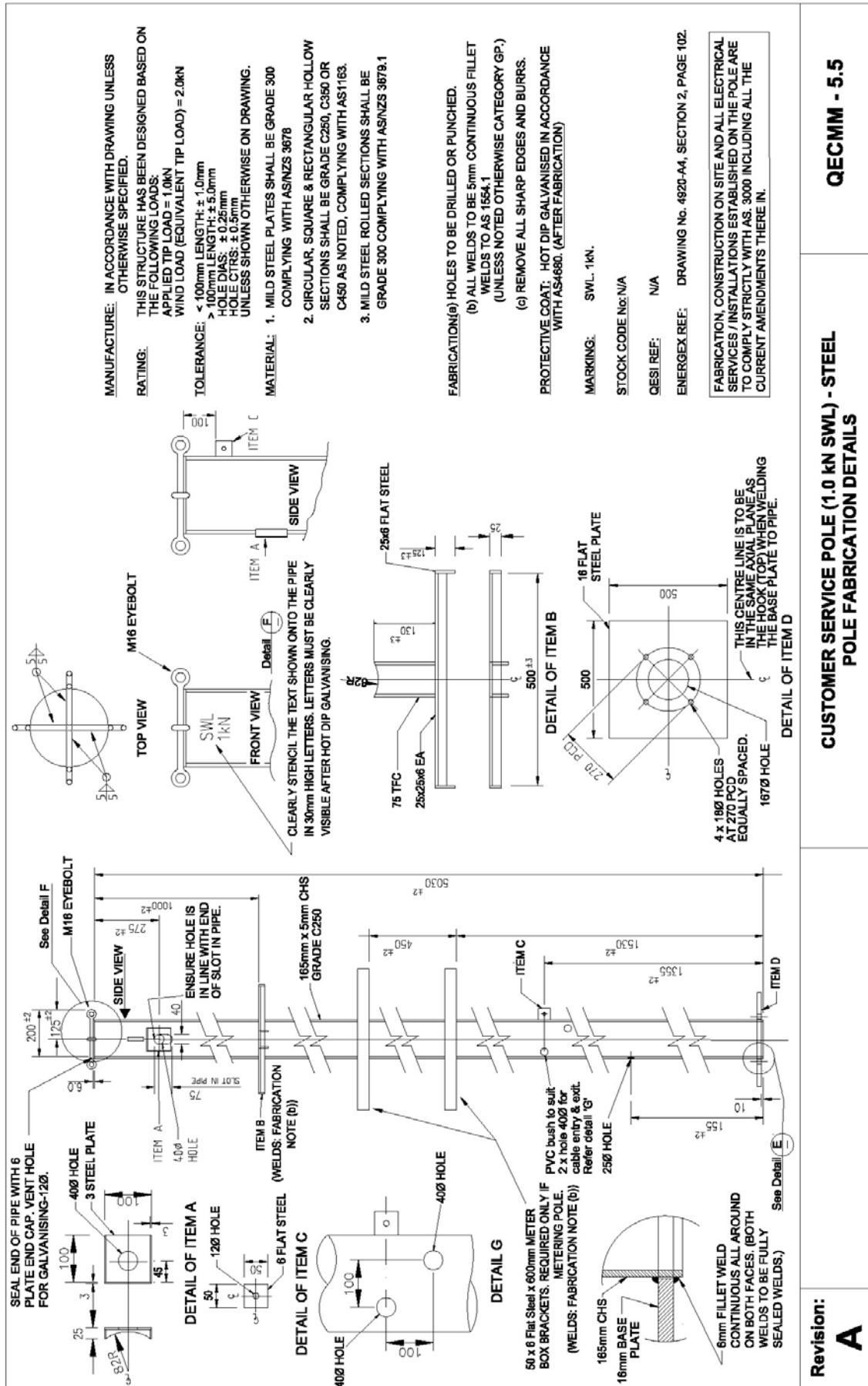

QECMM - 5.5

CUSTOMER SERVICE POLE (1.0 kN SWL) - STEEL POLE FABRICATION DETAILS

Revision: A

QLD Electricity Connection and Metering Manual



Part of the Energy Queensland Group

This Centre Line is to be directly in line with the Distributor's Pole from which the supply cable will be strung.

Section A

500 SQ.

FINISHED SURFACE LEVEL

CONSTRUCTION JOINT (As Required)

CONDUIT ENTRY FOR UNDERGROUND CABLE (As Required)

REINFORCEMENT CAGE (Refer Fabrication Detail)

CONCRETE F_c = 20MPa

75 MIN. COVER

Elevation

75 MIN. COVER

1500 SOCKET

450 DIA. MINIMUM

See Detail B

See Detail C

Section D

270 PCD

4 off N16 deformed bars

R6 Spiral Ligature at 220mm pitch

HOT DIPPED GALVANISED M16 HEX. HEAD NUTS AND FLAT WASHERS APART AND IN LINE FOR ASSEMBLY.

THREADED M16 x 150mm LONG

Detail C

4 off N16 deformed bars at 270 PCD equally spaced.

R6 Spiral Ligature spot welded to main bars at 220mm pitch. (Helix to have one complete turn at each end.)

Elevation

Detail B

HIGH STRENGTH CEMENT GROUT, (PACKED FROM 1 SIDE ONLY TO PREVENT VOIDS)

1xM16 HEX. HEAD NUT AND 1xM16 FLAT WASHER ON EACH FACE OF BASE PLATE AT EACH THREADED BAR. (Only Hot Dipped Galvanised Nuts and Washers to be used.)

BASE PLATE

FINISHED SURFACE LEVEL

Notes:

- All concrete work shall comply with AS.3600.
- Concrete Foundation:- F_c=20MPa., 80mm Slump, 20mm Max. AGG.
- Reinforcement :- Refer to fabrication details on this sheet.
- The owner/contractor shall be responsible for the correct setting out of works. The owner/contractor shall establish the actual position of all services on site before commencing work on the site.
- All excavation work and excavation protection shall comply with regulation 13 - "Workplace Health and Safety Regulations" - 1989 including latest amendments.
- The owner/contractor shall comply with acts of parliament, statutory, municipal and other regulations, or bylaws in any way affecting the working particular with regard to: (A) Workplace Health and Safety Act (B) Protection of Public Utilities (C) Traffic Hazards and Public Safety.
- The owner/contractor shall be responsible for any damage to public utility service installations such as water, gas and sewer pipes, electrical, traffic signal or telephone conduits and shall bear the costs of reinstating any services damaged during construction of the works.

This foundation has been designed based on Natural Ground having a minimum safe bearing capacity of 100kPa. Should the owner/contractor encounter unsuitable soil conditions at the site a Registered Professional Civil Engineer must be consulted prior to the construction of the foundation.

FABRICATION, CONSTRUCTION ON SITE AND ALL ELECTRICAL SERVICES / INSTALLATIONS ESTABLISHED ON THE POLE ARE TO COMPLY STRICTLY WITH AS/NZS 3000 INCLUDING ALL THE CURRENT AMENDMENTS THERE IN.

MATERIAL:
 N16 Deformed Bar Grade D500N conforming with AS4671
 R6 Structural Grade Plain Round Bar to AS. 1302
 Grade 230 R.
 M16 Hex. Head Nut Galvanised
 M16 Washer Flat Galvanised

FABRICATION:
 All welding in accordance with AS. 1554.1
 All resulting thread forms shall have a tolerance class of 6H/6g (in accordance with AS 1275)

PROTECTIVE COAT:
 Hot dip galvanised in accordance with AS. 4680 after fabrication.

REINFORCEMENT FABRICATION CONSTRUCTION DETAILS

CUSTOMER SERVICE POLE (1.0 KN SWL) - STEEL FOUNDATION CONSTRUCTION DETAILS

REVISION: **A**

QECMM - 5.6

QLD Electricity Connection and Metering Manual



Part of the Energy Queensland Group

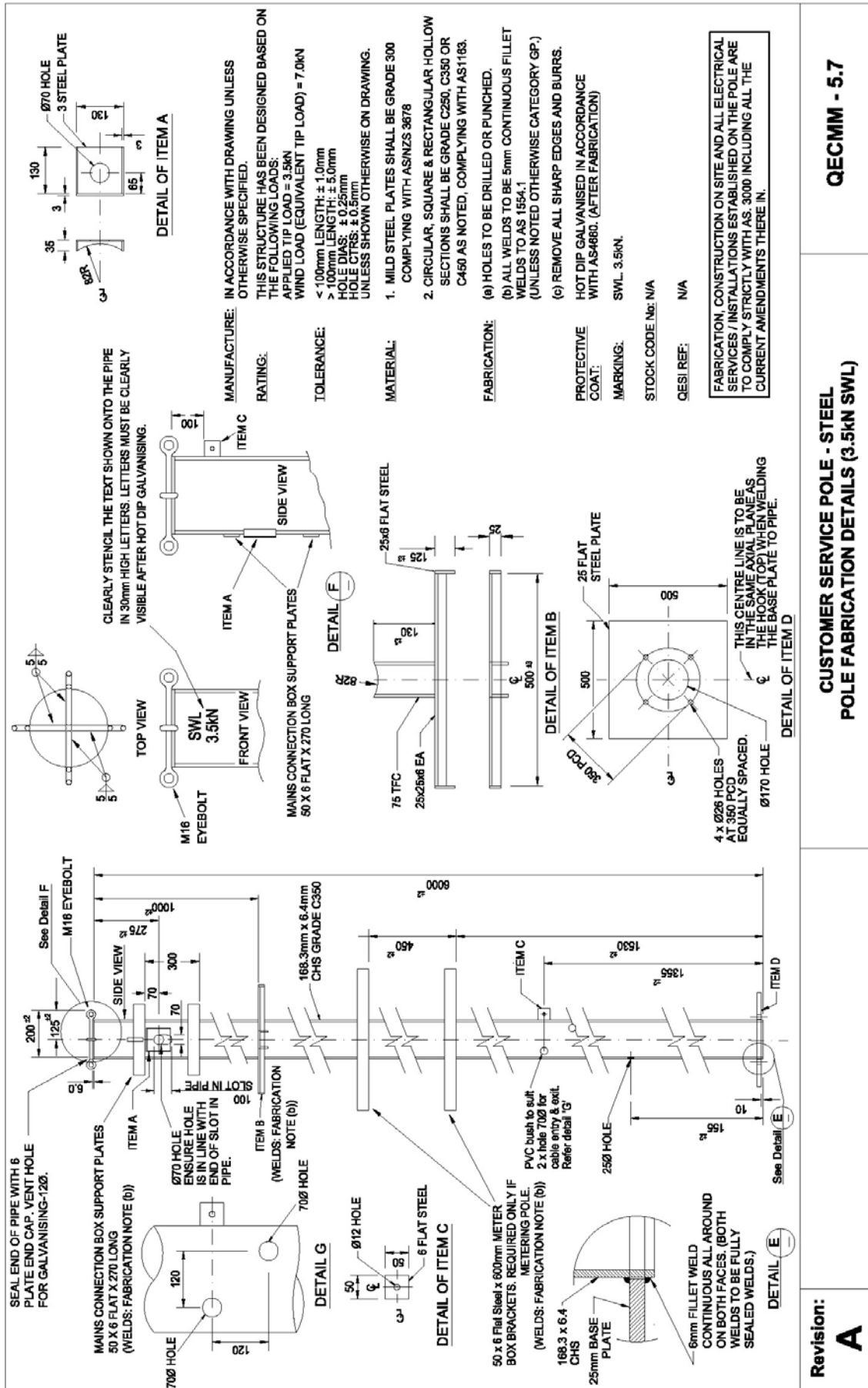

Revision:
A

**CUSTOMER SERVICE POLE - STEEL
POLE FABRICATION DETAILS (3.5kN SWL)**

QECMM - 5.7

QLD Electricity Connection and Metering Manual



Part of the Energy Queensland Group

Notes:

- All concrete work shall comply with AS:3600.
- Concrete Foundation: - $F_c=20\text{MPa}$, 80mm Slump, 20mm Max. AGG.
- Reinforcement :- Refer to fabrication details on this sheet.
- The owner/contractor shall be responsible for the correct setting out of works. The owner/contractor shall establish the actual position of all services on site before commencing work on the site.
- All excavation work and excavation protection shall comply with regulation 13 - "Workplace Health and Safety Regulations" - 1989 including latest amendments.
- The owner/contractor shall comply with acts of parliament, statutory, municipal and other regulations, or bylaws in any way affecting the working particular with regard to: (A) Workplace Health and Safety Act (B) Protection of Public Utilities (C) Traffic Hazards and Public Safety.
- The owner/contractor shall be responsible for any damage to public utility service installations such as water, gas and sewer pipes, electrical, traffic signal or telephone conduits and shall bear the costs of reinstating any service damaged during construction of the works.

This foundation has been designed based on Natural Ground having a minimum safe bearing capacity of 100kPa. Should the owner/contractor encounter unsuitable soil conditions at the site a Registered Professional Civil Engineer must be consulted prior to the construction of the foundation.

FABRICATION CONSTRUCTION ON SITE AND ALL ELECTRICAL SERVICES / INSTALLATIONS ESTABLISHED ON THE POLE ARE TO COMPLY STRICTLY WITH AS/NZS 3000 INCLUDING ALL THE CURRENT AMENDMENTS THERE IN.

MATERIAL:
M24 4.6/S Threaded rod grade 400 conforming with AS/NZS1111
R8 Structural Grade Plain Round Bar to AS: 1302 Grade 230 R.
M24 Hex Head Nut Galvanized
M24 Washer Flat Galvanized

FABRICATION:
All welding in accordance with AS: 1554.1
All resulting threaded forms shall have a tolerance class of 6H/8g (in accordance with AS 1275)
PROTECTIVE COAT:
Hot dip galvanized in accordance with AS: 4680 after fabrication.

REINFORCEMENT FABRICATION

Revision:
A

CONSTRUCTION DETAILS

QECMM - 5.8

QLD Electricity Connection and Metering Manual



Part of the Energy Queensland Group

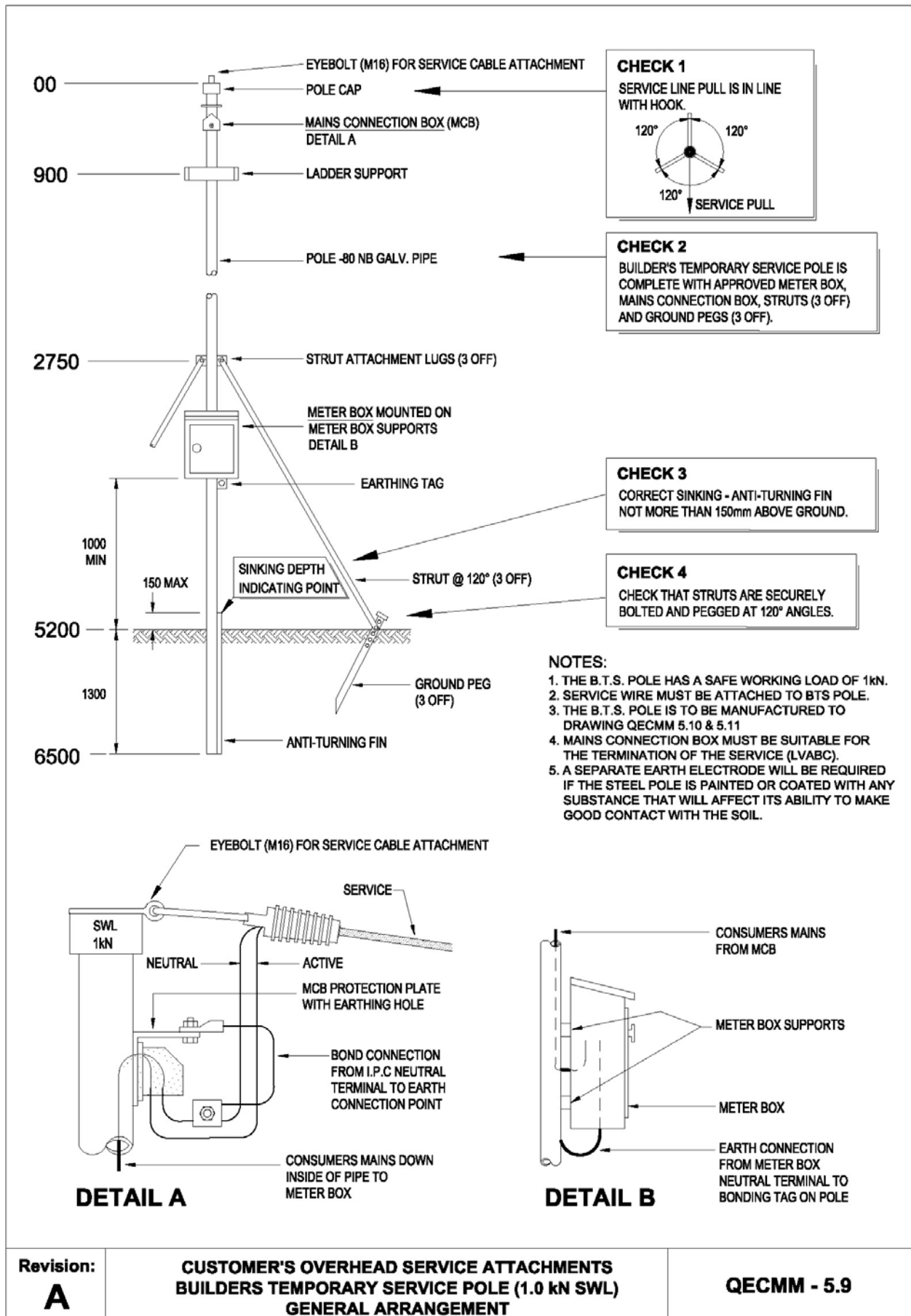

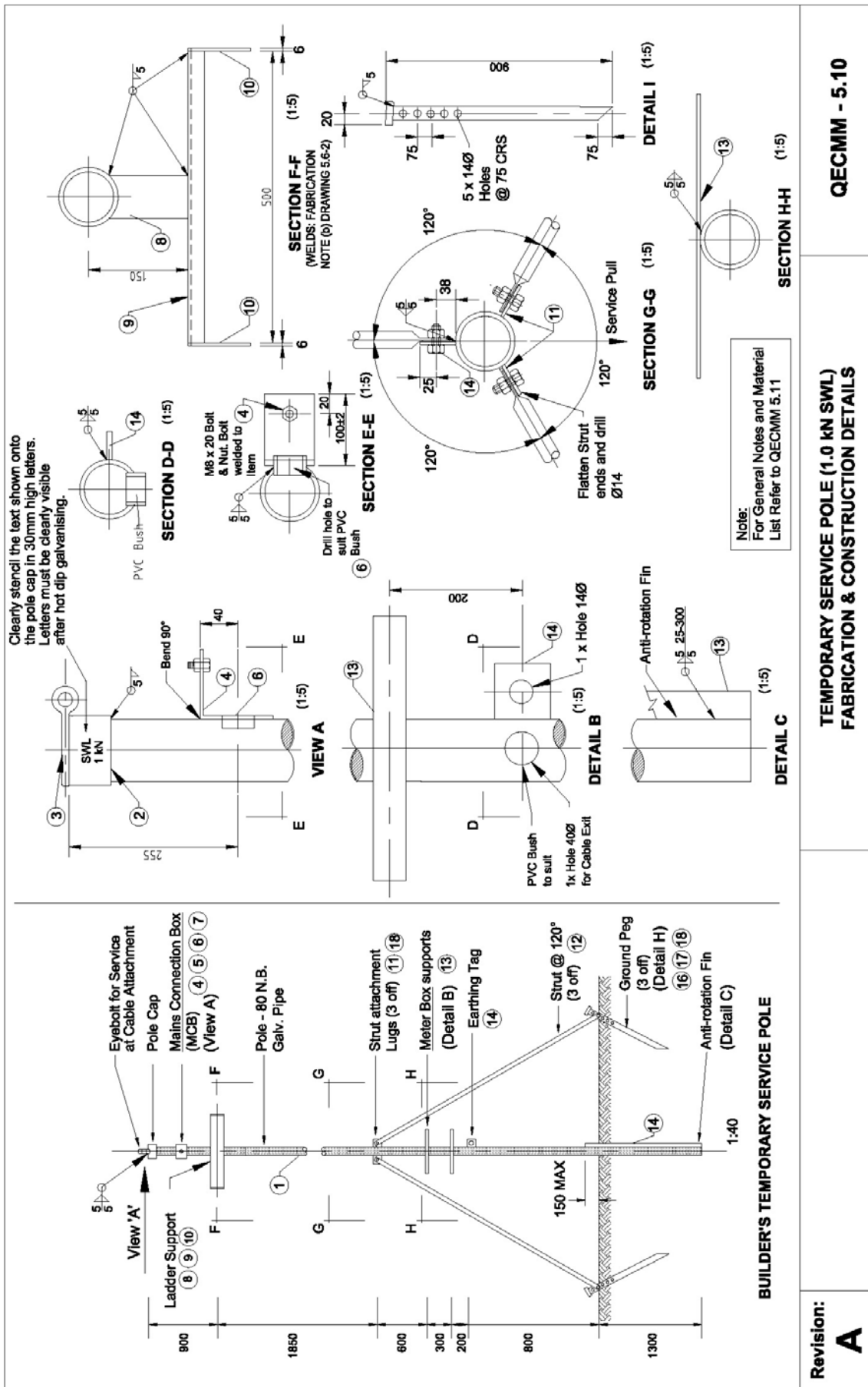

Revision: A

TEMPORARY SERVICE POLE (1.0 kN SWL) FABRICATION & CONSTRUCTION DETAILS

QECMM - 5.10

MATERIAL LIST			
Item	Description	No. Off	Description
①	Pole	1	80 N.B. x 4.0 Thk. x 6500Lg. Std. Galv. Pipe
②	Cap or Disc	1	To suit 80N.B. Pipe
③	Service Attachment Ring	1	M16 Eyebolt
④	Mains connection Box Baseplate	1	FL 75 x 3 x 200 Lg. Bent 90° as shown on drawing
⑤	Mains Connection Box	1	3 terminal clipal Cat. No. IP23
⑥	Threaded PVC Bush	1	To suit MCB
⑦	Screw (Drill & tap item-4 to suit MCB)	2	M5 x 12Lg. S/S Grade 304
⑧	Ladder Support Bracket	1	Taper-flange Channel
⑨	Ladder Support Member	1	L 25x25x6x500Lg
⑩	Ladder Stops	2	L 25x6x125Lg
⑪	Strut Attachment Lug	3	FL 75 x 10 x 75Lg.
⑫	Strut Members	3	25N.B. x 3150Lg. Std. Galv. Pipe
⑬	Meter Box Supports	2	FL 50 x 6 x 400Lg.
⑭	Earthing Lug	1	FL 50 x 6 x 50Lg.
⑮	Stabilising fin	1	FL 50 x 6 x 1450Lg.
⑯	Peg	3	L38 x 38 x 6 x 900Lg. (See Detail 3)
⑰	Striking Plate	3	FL 50 x 10 x 50 Lg.
⑱	Bolt & Nut	6	M12 x 40 Lg. Hex. Galv.

SPECIFICATIONS

RATING: This structure has been designed based on the following loads:
Applied tip load - 1.0 kN.

TOLERANCE: All tolerances to be ±5.0

MATERIAL: Structural steel in accordance with AS 4100.

MATERIAL: Structural Steel in Accordance with AS 1204 Grade 250. See material list for details.

FABRICATION:
(a) Holes to be drilled or punched undersize & reamed.
(b) Welding to be in accordance with AS 1554.1
(c) All sharp edges and burrs to be removed.

PROTECTIVE COAT: All steelwork to be effectively corrosion protected.

MARKING: SWL 1 kN

NOTES:
1. FOR CONSTRUCTION AND DETAILS REFER QECMM 5.10
2. NB = NOMINAL BORE

Revision: A	TEMPORARY SERVICE POLE (1.0 kN SWL) FABRICATION AND CONSTRUCTION DETAILS
	QECMM - 5.11

QLD Electricity Connection and Metering Manual

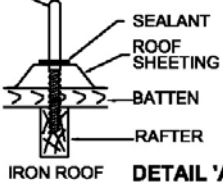
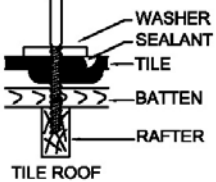
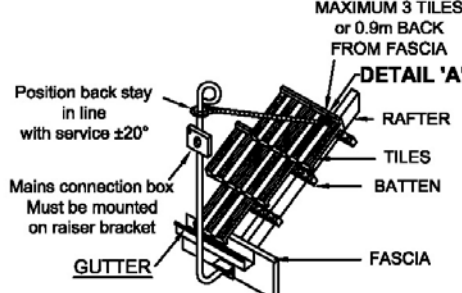
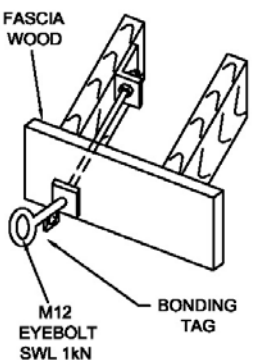
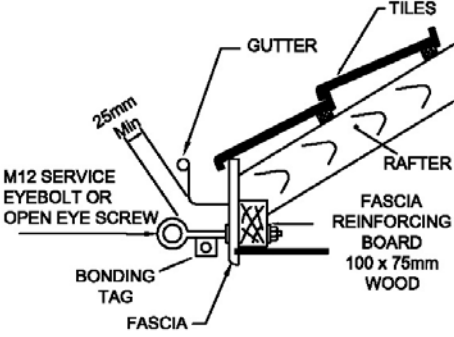
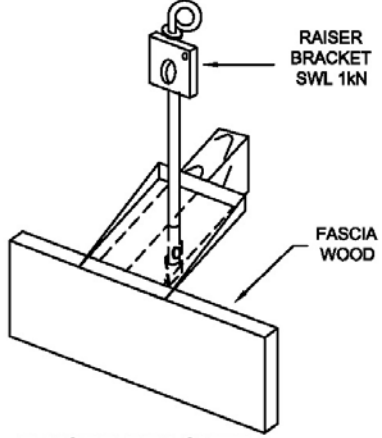
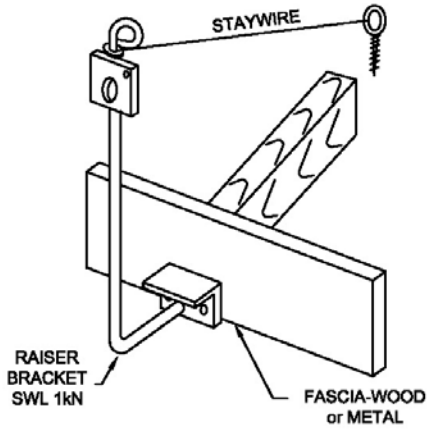
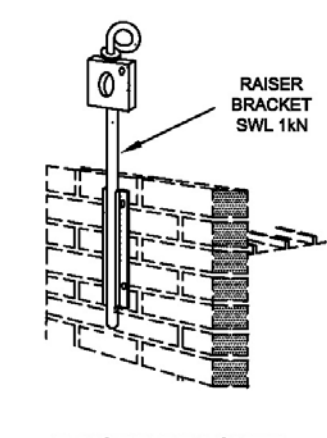
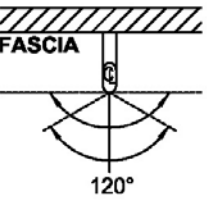
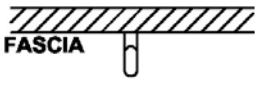

Part of the Energy Queensland Group

<p>Eyebolt/open eye screw to Manufacturers requirement</p>  <p>IRON ROOF DETAIL 'A'</p>  <p>TILE ROOF</p> <p>RAISER BRACKET - STAY DETAIL</p>  <p>Position back stay in line with service $\pm 20^\circ$</p> <p>Mains connection box Must be mounted on raiser bracket</p> <p>MAXIMUM 3 TILES or 0.9m BACK FROM FASCIA</p> <p>DETAIL 'A'</p> <p>RAFTER TILES BATTEN FASCIA GUTTER</p>	<p>EYEBOLT - TYPE 1</p>  <p>FASCIA WOOD M12 EYEBOLT SWL 1kN BONDING TAG</p> <p>EYEBOLT - TYPE 2</p>  <p>TILES GUTTER RAFTER FASCIA REINFORCING BOARD 100 x 75mm WOOD FASCIA BONDING TAG M12 SERVICE EYEBOLT OR OPEN EYE SCREW 25mm Min</p>	
<p>RAISER BRACKET RAFTER HOOK TYPE</p>  <p>RAISER BRACKET SWL 1kN FASCIA WOOD</p>	<p>RAISER BRACKET - FASCIA TYPE</p>  <p>STAYWIRE RAISER BRACKET SWL 1kN FASCIA-WOOD or METAL</p>	<p>RAISER BRACKET PARAPET TYPE</p>  <p>RAISER BRACKET SWL 1kN</p>
<p>DIRECTION OF SERVICE - RAISER BRACKET/OPEN EYE SCREW</p>  <p>FASCIA</p> <p>120°</p> <p>RAISER BRACKET: The raiser bracket is to be installed in accordance with Manufacturers instructions.</p> <p>NOTE: Services will not be connected where the bracket is installed incorrectly i.e. service direction altered without permission/agreement by Manufacturer.</p>	<p>DIRECTION OF SERVICE - EYEBOLT</p>  <p>FASCIA</p> <p>EYEBOLT Service permitted in any required position. Service must not come in contact with any structure and statutory clearances apply.</p>	
<p>NOTES</p> <ol style="list-style-type: none"> Manufacturers and Registered Professional Engineer Qld (RPEQ) installation instructions are to be followed in all cases - the detail in this drawing is INFORMATIVE ONLY. Raiser brackets and eyebolts are to be HOT DIPPED GALVANISED STEEL and marked with a suitable 'SWL rating'. Raiser brackets are to be certified by an RPEQ and approved by the distributor. 1kN raiser brackets must not be used to terminate 50/95mm² LVABC service. A 3.5kN raiser bracket or an eyebolt/open eye screw installed on a suitable portion of the building or a property pole is to be used. If the service bracket/eyebolt is within 25mm of any structural metal work e.g. guttering or metal fascia of the building, the distributor will bond between the service attachment and the neutral conductor of the service. The customer is to provide suitable means to connect bonding conductor. ie. Earth tag with 12mm hole. 		
<p>Revision: A</p>	<p>TYPICAL EXAMPLES FOR 25/35mm² LVABC (1kN) SERVICES ATTACHMENTS ON STRUCTURES - EYEBOLT & RAISER BRACKET</p>	<p>QECMM - 5.12</p>

CUSTOMER TO PROVIDE THE MEANS FOR ATTACHMENT AND CONNECTION OF THE SERVICE TO THE CUSTOMER'S INSTALLATION		
<p>REFER QECMM 5.12 FOR SERVICE ATTACHMENT DETAIL. PROVIDED BY CUSTOMER.</p> <p>THREE PHASE SERVICE ARRANGEMENT SHOWN</p> <p style="text-align: center;">25/35 mm² LVABC SERVICE CONNECTION WOOD OR METAL FASCIA</p>	<p>MCB WITH SERVICE CONNECTORS. PROVIDED BY CUSTOMER.</p> <p>THREE PHASE SERVICE ARRANGEMENT SHOWN</p> <p style="text-align: center;">25/35 mm² LVABC SERVICE CONNECTION GALVANISED STEEL RAISER BRACKET</p>	
<p>M12 SERVICE ATTACHMENT. OPEN EYE SCREW HOOK, OPEN EYEBOLT (THREADED), OR CLOSED EYEBOLT (THREADED). PROVIDED BY CUSTOMER.</p> <p>THREE PHASE SERVICE ARRANGEMENT SHOWN</p> <p style="text-align: center;">25/35 mm² LVABC SERVICE CONNECTION CUSTOMER'S WOOD POLE</p>	<p>BOND CONNECTION (IF REQUIRED TO BE EQUIVALENT SIZE OF SERVICE MAINS) PROVIDED BY DISTRIBUTOR</p> <p>THREE PHASE SERVICE ARRANGEMENT SHOWN</p> <p style="text-align: center;">25/35 mm² LVABC SERVICE CONNECTION CUSTOMER'S CONDUCTIVE POLE</p>	
<p>NOTES</p> <ol style="list-style-type: none"> 1. TO PREVENT CORROSION COPPER CONDUCTORS SHALL NOT BE DIRECTLY CONNECTED TO GALVANISED SURFACES. 2. CUSTOMER TO SUPPLY AND INSTALL APPROVED MAINS CONNECTION BOX OR NON-METALLIC UV STABILISED WEATHERPROOF ENCLOSURE. (REFER TO CLAUSE 5.4.6(e) SEE DETAIL FOR MIN SIZE. 		
<p>Revision: A</p>	<p>CUSTOMER'S OVERHEAD SERVICE ATTACHMENTS 1.0kN SWL CONNECTION AND BRIDGING DETAIL</p>	<p>QECMM - 5.13</p>

CUSTOMER TO PROVIDE THE MEANS FOR ATTACHMENT AND CONNECTION OF THE SERVICE TO THE CUSTOMER'S INSTALLATION

UP TO 200 AMP

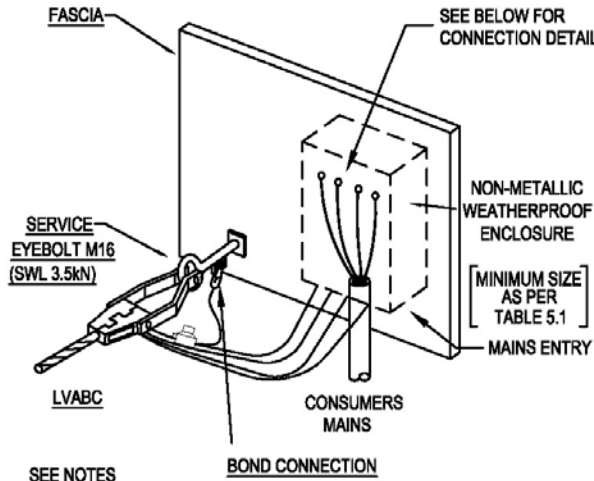

SEE NOTES

TYPICAL LVABC TO SINGLE CONSUMERS MAINS CONNECTION DETAIL

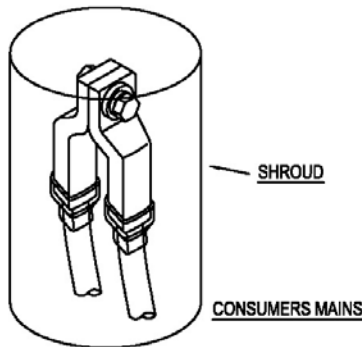

LVABC CONNECTION TO SINGLE CONSUMERS MAINS

200/400 AMP

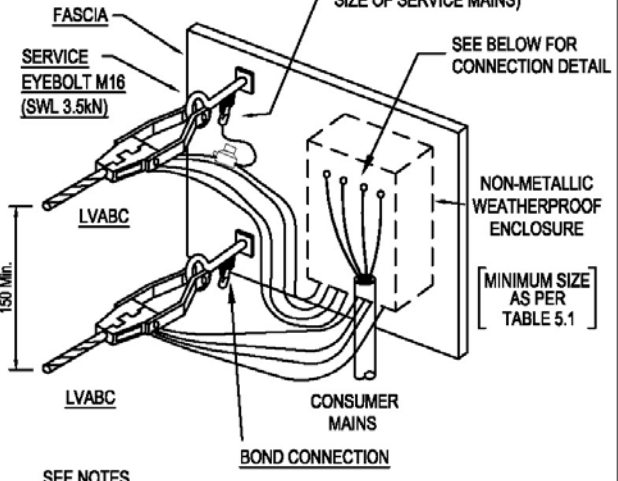

SEE NOTES

TYPICAL LVABC TO PARALLEL SERVICES MAINS CONNECTION DETAIL

NOTES

1. CUSTOMER TO SUPPLY AND INSTALL APPROVED MAINS CONNECTION BOX OR NON-METALLIC UV STABILISED WEATHERPROOF ENCLOSURE AND SUITABLE LUGS. (REFER TO CLAUSE 5.4.6(e). SEE DETAIL FOR MIN SIZE)
2. CUSTOMER TO SUPPLY LUGS TO SUIT CURRENT RATING OF CABLE AND SHALL ACCOMMODATE A 12MM S/S BOLT. CUSTOMER TO SUPPLY LUG DIES WHERE REQUIRED. CONSUMERS MAINS TO ENTER THROUGH BOTTOM OF ENCLOSURE.
3. ALTERNATE CONNECTIONS METHOD USE APPROPRIATE COPPER BUS BAR.
4. COVER WITH INSULATING SHROUD AND SECURE WITH ZIP TIE.
5. THE BONDING OF EXPOSED METALWORK (EYEBOLT) MUST USE A CONDUCTOR SIZE THE SAME AS THE LVABC NEUTRAL.
6. IPC'S MUST BE USED TO CONNECT ALL EARTHING CONDUCTORS TO LVABC NEUTRAL.

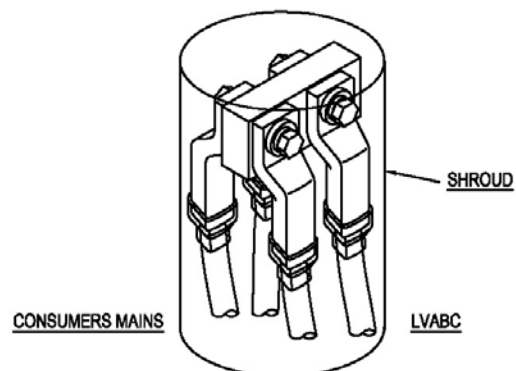

LVABC CONNECTION TO PARALLEL CONSUMERS MAINS

Revision:

A

CUSTOMER'S OVERHEAD SERVICE ATTACHMENTS CONNECTION AND BRIDGING DETAIL FOR SINGLE AND PARALLEL LVABC SERVICES FOR C & I INSTALLATIONS (MAX 400 A)

QECMM - 5.14

ERGON ENERGY ONLY		
<p>Hot dipped galvanized service attachment eyebolt (M16) with bonding tab swl 3.5kN Provided by customer</p> <p>Mains connection box c/w service connectors Provided by customer</p> <p>Termination clamp Provided by Distributor</p> <p>Service cable</p> <p>Wood or metal Fascia</p> <div style="border: 1px solid black; padding: 2px; width: fit-content;"> <p>Bond connection Req'd to service eyebolt Provided by Distributor</p> </div> <p style="text-align: center;">50/95mm² LV ABC SERVICE CONNECTION WOOD OR METAL FASCIA - 3.5kN SWL</p>	<p>Termination clamp Provided by Distributor</p> <p>Stay Provided by customer</p> <p>Service cable</p> <div style="border: 1px solid black; padding: 2px; width: fit-content;"> <p>Bond connection Req'd to service eyebolt Provided by Distributor</p> </div> <p>Hot dipped galvanized steel raiser bracket swl 3.5kN Provided by customer</p> <p>Mains connection box c/w service connectors Provided by customer</p> <p style="text-align: center;">50/95mm² LV ABC SERVICE CONNECTION GALVANISED STEEL RISER BRACKET - 3.5kN SWL</p>	
<p>Hot dipped galvanized service attachment eyebolt (M16) with bonding tab SWL 3.5kN Provided by customer</p> <p>Mains connection box c/w service connectors and hot dipped galvanized mounting bracket Provided by customer</p> <p>Termination clamp Provided by Distributor</p> <p>Service cable</p> <p>Wood Pole</p> <p>Consumers mains</p> <div style="border: 1px solid black; padding: 2px; width: fit-content;"> <p>Bond connection Req'd to service eyebolt Provided by Distributor</p> </div> <p style="text-align: center;">50/95mm² LV ABC SERVICE CONNECTION CUSTOMER'S WOOD POLE</p>	<p>Hot dipped galvanized service attachment eyebolt (M16) with bonding tab SWL 3.5kN Provided by customer</p> <p>Termination clamp Provided by Distributor</p> <p>Service cable</p> <p>Conductive Pole</p> <p>Consumers mains</p> <div style="border: 1px solid black; padding: 2px; width: fit-content;"> <p>Bond connection Req'd to service eyebolt Provided by Distributor</p> </div> <p>Mains connection box c/w service connectors and hot dipped galvanized mounting bracket Provided by customer</p> <p style="text-align: center;">50/95mm² LV ABC SERVICE CONNECTION CUSTOMER'S CONDUCTIVE POLE</p>	
<p>Revision: A</p>	<p>MAINS CONNECTION BOX WITH SERVICE CONNECTORS 50/95 mm² LVABC SERVICE - 3.5kN SWL ATTACHMENTS</p>	<p>QECMM - 5.15</p>

QLD Electricity Connection and Metering Manual



Part of the Energy Queensland Group

THIS PAGE HAS BEEN DELIBERATELY LEFT BLANK

6. METERING REQUIREMENTS

The information in Sections 6 to 8 is for Power of Choice areas only i.e. connected to the National Electricity Market (NEM).

For Power of Choice exempt areas i.e. not connected to the National Electricity Market (non-NEM) refer to Appendix D. This includes all remote generation sites and the Mt Isa Network.

6.1. General

This section includes indicative advice on metering requirements, for specific information contact the *metering provider*.

Where a *customer* directs a *retailer* to request metering or tariff changes, any alterations to the *customer's* switchboard installation or meter enclosure shall be the *customer's* responsibility (e.g. removal of asbestos contaminated waste) (Refer to Clause 6.12).

Metering equipment deemed to be necessary by the *metering provider* to record electricity consumption shall be supplied and maintained by the *metering provider* and shall remain their property.

Network devices deemed to be necessary to control electricity consumption shall be supplied and maintained by the *distributor* and shall remain their property. All meter and *network device* active terminals shall be connected directly to the Metering Isolation Link or Metering Active Link for direct connected installations.

Where it is known that a single tariff two or three-phase supply will be required at the time of initial connection, provision for the metering shall be installed at this time in accordance with the requirements of the *metering provider*. It is anticipated that this will be a polyphase meter. All phases of a service line are required to be connected at the initial connection of the premises.

All metering and control equipment shall be back-wired and mounted on a hinged panel attached to a metering enclosure or a switchboard frame.

For multiple tenancy installations, access to sub boards within tenancies will be required for verification of submains and metering. (Refer to Clause 2.7).

Where metering or control equipment is no longer required, the *metering provider* shall be contacted to arrange for its removal.

Customer's ancillary equipment such as surge diverters, voltmeters, phase failure relays etc. shall be connected on the load side of the revenue metering equipment. *Customer* owned current transformers for energy management are permitted on the line side of revenue metering equipment at multiple tenancy installations.

6.2. Metering Determination

Customer's installations other than those approved by the *distributor* as suitable for *unmetered supply* (e.g. non-standard installations located on public land (refer to Clauses 2.6 and 5.9)) will be metered by one of the following methods:

- (a) *Direct connected meters*; or
- (b) *Current transformer metering*; or
- (c) HV current transformer - voltage transformer metering. (Refer to Section 9).

The *customer* (or their *electrical contractor*) is responsible for determining and monitoring the installation's load requirements, and method of metering (i.e. *direct connected* or *current transformer metering*). This applies to new connections and/or alterations or additions. The *customer* may need to consult with the *customer's retailer* at the earliest opportunity in order to determine their metering requirements.

6.3. Controlled loads

Where *controlled loads* are required (Controlled Supply/Night Rate tariffs), provision for a separate *network device* shall be made (Refer to Drawing QECMM 6.1 for cable access drilling details). The *network device* will only be installed when the *customer* has requested *controlled load* as part of the EWR for the installation.

Section 7 contains more detail on requirements for connection of controlled loads

6.4. Customers Energy Management Systems

A *customer* requiring an interface with the *metering provider's* facilities should contact the *metering provider*.

6.5. Sealing of Metering Equipment

The *metering provider* will seal all the metering equipment and may seal cubicles or panels which house revenue metering equipment, or *unmetered* sections of a switchboard. It is an offence to break or interfere with any seal unless authorised by the *metering provider*.

Meters, *network devices*, metering isolation links, metering neutral links, metering active links, voltage circuit fuses and contactors associated with the metering, and which are required as a condition of a supply arrangement (e.g. *controlled supply*), are typical of equipment that requires sealing.

The *customer* shall make provision for the sealing of all *current transformer metering* panels, dedicated current transformer and voltage transformer chambers and HV metering panels.

6.6. Metering Isolation

To facilitate the requirements of the *Electrical Safety Act 2002* and *Electrical Safety Regulation 2013* for performing electrical work, and the *Electricity Act 1994* and *Electricity Regulation 2006*, supply to the revenue metering equipment for each *customer* is to be capable of being individually isolated.

All metering shall be connected with suitable active isolation devices connected to the line side of the metering to allow safe access to the metering equipment.

6.6.1 Isolation of *Direct Connected Metering*

Direct connected metering shall be installed on the line side of the individual installation's main switches.

6.6.1.1 Single Installations

A metering isolation link per phase shall be connected to the line side of the metering. This arrangement maintains supply to electronic meters. (Refer to Clause 6.6.2 and Drawing QECMM 6.2).

Exception:

Where overload protection for the *consumer's mains*, in accordance with AS/NZS 3000 (Wiring Rules), cannot be achieved by the positioning of the installation's circuit breaker main switches on the load side of the metering the following shall apply:

A metering isolation D curve circuit breaker connected on the line side of the metering, and sized for overload protection of the *consumer's mains*, shall be installed on the front of the meter panel in place of the metering isolation link. The circuit breaker shall be enclosed in a sealable non-metallic enclosure with a clear cover to allow the *customer* to determine if the circuit breaker is in the open or closed position without removing the cover.

Notes:

1. Enclosures that are lockable only are not acceptable.
2. The *distributor's* service fuse shall not be considered as overload protection (refer to Clause 2.8).
3. Where metering isolation circuit breakers are used in a three phase installation, all three phases must have circuit breakers. If individual CBs are used they must comply with Clause 6.6.2.

If the marking on the circuit breaker is not legible when the cover is in place, the open and closed positions are to be identified by additional marking on the enclosure.

A permanent indelible label shall be fixed on or adjacent to the circuit breaker enclosure stating the following:

Metering isolation circuit breaker
Contact an Electrical Contractor if off.

6.6.1.2 Multiple Installations

A lockable load-break isolator (with facility for locking off) that is capable of isolating supply to the entire electrical installation shall be installed for all multiple *customer* installations including multiple *customers* fed from remote metering points. Where a circuit breaker main switch is installed for overload protection of the *consumer's mains* in accordance with AS/NZS 3000 (Wiring Rules), it shall be lockable, connected on the line side of the metering and can be used in place of the building isolator (Refer to Drawings QECMM 6.3-1 and 6.3-2).

Metering isolation links are required for individual *customers*. (Refer to Clause 6.6.2).

6.6.1.3 Metering Isolation - Existing Installations

When minor work is being carried out at an existing installation (including a like for like meter change, *network device* change or connection of additional circuits) it will not be necessary to alter the wiring of the meter to before the main switch. (Refer to the notes below).

This change need only be made where there is a major alteration to the metering or switchboard (for example where the switchboard is replaced, when replacing single phase meters with a polyphase meter or connection of additional phase/s). This will include the addition of metering isolation link/s (Refer to Clause 6.6.1.1).

All meters at the one meter location must follow the same sequence (i.e. be either all "before" or all "after" the main switch/s or any lockable isolator).

Exceptions:

1. Where *direct connected* meters are installed to facilitate a *customer* requested supply/tariff change, additional tariffs (e.g. controlled supply tariff) or installation of an *MEGU* on an existing single *customer* installation, they shall be connected on the line side of the individual installation's switchgear and provision for isolation is required in accordance with Clause 6.6.1.1.
2. On existing multi-tenancy installations where the individual tenancy main switch is connected on the line side of the meters, a new meter shall be connected on the line side of the individual tenancy main switch. A means of isolation in accordance with Clause 6.6.1.1 must be provided to allow isolation of the meter without interrupting supply to other *customers*.
3. On existing single phase multi-tenancy installations utilising plug-in meters, the need to fit isolation link/s is not required in situations where a replacement plug-in meter is to be used. These include a single phase tenancy with a *Micro Embedded Generating Unit (MEGU)* or a tenancy with Time of Use metering (TOU)

Notes for Clause 6.6.1.3:

1. Where the *distributor's* service fuse is greater than 100A, fault current limiting devices (supplied and installed by the *customer*) complying with AS/NZS 3000 (Wiring Rules), are required to protect any *direct connected meters*. Fault current limiting devices shall be installed within the first 500 mm of the take off point. (Refer to Drawings QECMM 6.3-1 and 6.3-2).
2. Standard practice in multiple tenancy *direct connected metering* installations, where the service fuse protection is greater than 100A, is to install a 100A fuse in the metering isolation link in place of the solid link. Where fuses are installed, the *metering provider* will provide the fuse and place a label on the panel adjacent to the metering isolation links stating: "WARNING - The metering isolation links have been fused for protection of *metering provider* Equipment".
3. Where the *metering provider* determines that the meter requires an 80A fuse for adequate overload/fault protection, *metering providers* can install an 80A fuse in the metering isolation link provided the Maximum Demand of the installation does not exceed 80A. Should a 100A supply be required, the *metering provider* shall ensure the meter used is suitably rated for, and protected by, the 100A service fuse. All other requirements of Notes 1 and 2 above remain applicable.

6.6.2 Metering Isolation Links/CBs

Metering isolation links/CBs shall be installed in accordance with the following:

- (a) Metering isolation links shall be clear cased type that comply with AS 60269, sealable, back wired, fitted with a tubular link and installed on the line side of all *direct connected metering* equipment; and
- (b) All metering isolation links/CBs on a metering panel shall be connected in the same line - load sequence; and
- (c) The metering isolation links shall be mounted horizontally or vertically on the front of the metering panel and if not obvious, clearly labelled to indicate the meter and portion of the installation that they control. Clearance around the ends of metering isolation links shall be 40mm; and

- (d) The load through a metering isolation link/CB shall not exceed 125A. In multiple supply applications (e.g. general and *controlled supplies*), where the load exceeds 125A, additional metering isolation links/CBs shall be required. Where a fuse is used to replace the solid link (Refer to Clause 6.6.1.3) the maximum load through the metering isolation link shall not exceed the rating of the fuse; and
- (e) On multiple installations metering isolation links/CBs shall be provided for each *network device* and installed on or adjacent to the relevant meter/metering equipment; and
- (f) For *customers* with three phase supply the metering isolation links/CBs are to be grouped together and if not obvious, permanent labelling must be applied to the meter panel to show the meter(s) and installation that they control.

Within the Energex distribution area where metering isolation links are fitted on an existing meter panel with surface wiring a front wired metering isolation link suitable for this purpose is acceptable.

Aluminium cables are not suitable for connection directly into Metering Isolation Link terminals unless fitted with a suitable means of termination, such as a soft-form bi-metallic sleeve or ferrule that is compatible with the Metering Isolation Link terminal metal.

Where cables of these types are used as *consumers mains*, they shall comply with the requirements of the electrical component/cable manufacturers and AS/NZS 3000, particularly in regard to termination and bending.

6.6.3 Isolation of *Current Transformer Metering*

Current Transformer metering shall be capable of being individually isolated by a suitable isolator or main switch. All isolation equipment shall be clearly identified and readily accessible and shall be installed and maintained by the *customer*.

Where *direct connected metering* is installed at the same switchboard as *current transformer metering*, the *direct connected metering* is to comply with Clause 6.6.1.

(a) Specific Single *Customer Current Transformer Metered* Installations

Specific single *customer current transformer metered* installations include installations where:

- (i) Supply to the installation is interrupted for extended continuous periods of time (>2 days) e.g. irrigation pumps, flood lifters, grain silos etc. (i.e. where the main switch is used to control the installation and leave the electronic meter without supply so that it cannot be read); or
- (ii) "Safety Services" are installed and require supply to be maintained.

Note: AS/NZS 3000 (Wiring Rules) permits lockable isolators for installations supplying "Safety Services".

In these specific single *customer current transformer metered* installations the *customer* shall install a lockable load-break isolator (with facility for locking on and off) on the line side of the *current transformer metering* chamber with the main switch(s) installed on the load side. In these specific installations, the isolator may be locked in the on position. (Refer to Drawing QECMM 6.3-2).

Where the metering current transformers are installed remote from the main switchboard, the isolator shall be marked "Metering Isolator".

(b) Other Single *Customer Current Transformer Metered* Installations

This includes all other single *customer current transformer metered* installations where supply to the meter will not be interrupted for extended continuous periods of time.

The preferred arrangement is to connect all single *customer current transformer metered* installations as per (a) above, however, in the interests of reducing costs to the *customer*, a main switch used as the lockable isolator installed on the line side of the *current transformer metering* is permitted provided isolation of customer outgoing circuits is still provided on the same switchboard as the CTs. The main switch shall be capable of being locked in the off position. (Refer to Drawing QECMM 6.3-2).

(c) Multiple *Customer Current Transformer Metered* Installations

(i) Isolation of entire installation (Building Isolator).

A lockable load-break isolator (with facility for locking off) that is capable of isolating supply to the entire electrical installation is required.

Note: A charge will be made where the *distributor* is required to isolate supply.

(ii) Isolation of individual *customers*.

A lockable load-break isolator (with facility for locking off) shall be installed on the line side of each set of revenue metering current transformers with the *customer's* main switch(s) installed on the load side located on the same switchboard as the CTs. (Refer to Drawings QECMM 6.3-1 and 6.3-2).

6.7. Metering Active and Neutral Requirements

6.7.1 Connection of Metering Neutral Conductors to Main Neutral

The metering neutral shall be connected to the main neutral in such a manner that it cannot be disconnected or removed, e.g.

- (a) Soldered or crimped to the main neutral;
- (b) A flag lug under the main neutral connection. Slotted lugs shall not be used;
- (c) A sealable terminal or bolt on the neutral link/bar where -
 - (i) the *consumer's mains* are a busway or busbar arrangement;
 - (ii) the installation main switchboard is supplied by more than one *connection point* and a bus-tie arrangement is in place (the *consumer's mains* neutrals shall be connected to a common neutral link/bar);
- (d) Where the main neutral conductor is 25 mm² or larger a sealable terminal may be used;
- (e) Under a stud fitted with a suitable nut that is drilled and tapped into the *consumer's mains* neutral lug, provided the arrangement can be sealed.

Note: In domestic installations where parallel *consumer's mains* are used the metering neutral conductor shall be soldered to one conductor only.

6.7.2 Accessibility of Neutral Connections

The metering neutral connection is to be readily accessible and shall not be located behind a panel where access requires isolation of supply. (Refer to Clause 6.23.3.8 for meter neutral label).

On heavy current switchboards (Refer to AS/NZS 3000 (Wiring Rules)) the main neutral and MEN connections to the busbar shall be located in an accessible position with a minimum of 600mm clearance from exposed live parts. If a minimum clearance of 600mm cannot be achieved, the use of a permanent barrier or location within a chamber separate from that of the main switch or other exposed live parts is acceptable.

The arrangement must allow the main neutral and MEN connections to be safely accessed without isolating the supply to the switchboard or moving other cables. (Refer to AS/NZS 3000 (Wiring Rules)).

The use of shrouds over cable connections is not a sufficient barrier as the shrouds need to be removed during polarity testing (unless access to conductors is provided via test probe holes without the need to remove the shrouds).

6.7.3 Metering Neutral Links

The metering neutral shall be connected to a dedicated terminal of a metering neutral link.

All meter and *network device* neutral terminals shall be connected to a dedicated terminal of the metering neutral link via a separate neutral conductor.

Soldered meter and *network device* neutral connections are not permitted.

Existing installations

Where *direct connected* meters are installed to facilitate a *customer* requested supply/tariff change, additional tariffs (e.g. controlled supply tariff) or installation of an *MEGU* on an existing single *customer* installation, a metering neutral link shall be installed and connected as per the requirements of Clause 6.7.3.

6.7.4 Metering Active Links

Where common *consumer's mains* are installed for the purpose of supplying more than one *customer*, metering active links shall be used.

Exemption: It is acceptable to loop from the spare line side terminal of the metering isolation link provided the rating of the link is not exceeded and it is compliant with Clause 3.2.2.

Metering active links may be required to facilitate the ease of connecting large cables to metering isolation links in multi-tenancy installations. (Refer to Drawings QECMM 7.4 and QECMM 6.3-2).

6.7.5 Metering Active and Neutral Link Construction

Metering active and neutral links shall -

- (a) incorporate a separate connecting device for the incoming and each outgoing circuit; and

- (b) consist of tunnel terminals using either of methods (i); (ii) or (iii) for termination of the conductors.
 - (i) Two screws shall be provided for each terminal; or
 - (ii) One screw, the outside diameter of which is not less than 80% of the tunnel diameter; or
 - (iii) One screw, which is arranged so that the conductor is clamped by suitable ferrules or plates in direct contact with the conductor.

Where metering active or neutral links are used, they must be sealable or, where this facility does not exist (for larger sized *consumer's mains*), the links must be installed within a suitable dedicated enclosure fitted with a sealable cover.

6.7.6 Metering Active and Neutral Link Mounting

Metering active and neutral links shall be mounted on the rear of the meter panel or meter enclosure.

Where metering active and neutral links are mounted on the rear of the meter panel, they shall be mounted in such a way that they do not interfere with the mounting of the metering equipment.

To not interfere with metering equipment (normally mounted on the upper or middle section of the meter panel) it is preferable for the metering active and neutral links to be mounted as close as practical to the bottom of the meter panel.

Where metering active and neutral links are mounted on the rear of the meter enclosure and the material on which they are mounted is conductive, they shall be mounted on insulating material with low water absorption properties that will extend past the live parts of the link by a minimum of 25mm in all directions. This mounting arrangement is not required where the link has been specifically designed and type tested for installation onto metal surfaces.

Access to metering links must not be obstructed by any structure or wiring within the switchboard.

6.7.7 Metering Active and Neutral Link Labelling

A permanent label is required on the front of the meter panel to indicate the location of the metering active and neutral links.

Metering active and neutral links shall be identified as such and marked to identify which meter is fed from each outgoing circuit of the metering link. Labelling must be legible and durable in accordance with AS/NZS 3000.

6.8. Conductor Identification

To assist in identification of conductors and correct phase sequencing of polyphase meters, the individual conductors of *consumer's mains* shall be clearly identified at both ends (including up to each set of Metering Isolation Links) by colour coding of the conductor insulation (e.g. red, white and dark blue to identify active conductors). This identification may be achieved by installation of 150mm minimum of colour coded sleeving installed at the conductor terminations (e.g. at the service pillar, mains connection box, transformer terminals, switchboard/metering panel MILs etc). Insulation tape is not an acceptable means of identification.

6.9. Metering requirements for a Builder's Temporary Service (BTS)

Builder's Temporary Services are required to comply with all metering requirements of the QECMM for typical metering installations. These requirements include but are not limited to:

- All metering and control equipment shall be back-wired and mounted on a hinged panel attached to a metering enclosure or a switchboard frame. (Refer to Clause 6.1).
- A metering isolation link per phase shall be connected to the line side of the metering. (Refer to Clause 6.6).
- An eyebolt/screw/closed attachment must be used as per general arrangement drawing. (Refer QECMM 5.9).

Builder's Temporary Services are exempt from Clause 6.14.5 as they do not need to be dedicated to revenue metering equipment.

6.10. Metering and Control Equipment - Accommodation

The *customer* shall provide and maintain at their expense, suitable space, housing, mounting and connecting facilities to accommodate meters and control equipment for each supply arrangement (e.g. general and *controlled supplies*).

Unless otherwise specified and agreed with the *distributor*, the minimum space requirements for *high voltage metering* panels shall be as specified in Section 9.

6.11. Metering and Control Equipment - Position

6.11.1 General

Meters and control equipment shall be positioned so that they are not subjected to mechanical damage, vibration, high temperature or other environmental situations that might affect their correct operation (e.g. exposure to direct sunlight). Where security of a meter enclosure is necessary, a metering lock must be purchased to allow access. (Refer to Clause 6.15).

The *customer* shall provide safe and ready access so that meters and control equipment may be fixed, read, tested, adjusted and removed without difficulty at any reasonable time but generally between the hours of 8.00am to 5.00pm Monday to Friday. The minimum access requirements for a meter enclosure shall be as per the requirements for switchboards as detailed in AS/NZS 3000 (Wiring Rules).

Unless otherwise approved by the *distributor*, or as varied by Clause 6.11.3, all meters and control equipment supplied for any one installation (as defined in the National Electricity Rules) shall be located in one readily accessible position, preferably on an outside wall at the front of the building.

Current transformer meters should be installed towards the front of the building on a readily accessible outside wall.

Note: Where a property or building is of a type that may be subdivided, the meters and wiring should be located in an area that would be set aside as *common property* or within each individual lot.

6.11.2 Domestic Properties

On domestic *premises* a meter position suitable to the *distributor* shall satisfy the following criteria:

- (a) Unless otherwise approved in writing by the *distributor*, meters shall be erected on the side of the *premises* facing a street from which there is pedestrian access or within the first 2 m along an adjacent side of the *premises*. (Refer to Drawing QECMM 6.4).
- (b) Meters shall not be located behind any fence in an urban area, other than the perimeter fence located at the extremities of the property boundary.

Where access to meters is through locked gates in the perimeter fence, the *distributor's* metering lock purchased from an authorised locksmith must be installed. The lock must be accessible from outside the gate. (Refer to Clause 6.15).

Note: Key/security card boxes or dual locking bars are acceptable.

- (c) On domestic rural or *urban* properties greater than half a hectare, the metering equipment shall be situated in a readily accessible position in accordance with (a) and or (d) of this clause.
- (d) For acreage and farm properties the metering equipment shall be accessible by motor vehicles.

Note: The preferred meter position is at the main residence, central meter position or at the front property boundary.

6.11.3 Unmetered Submains

6.11.3.1 Unmetered Submains - General

Details of the proposed meter positions, *unmetered* submains and their circuit protective devices shall be submitted to the *distributor* for approval before their installation.

Exception: Approval is not required where the *unmetered* submains comply with Clauses 6.11.3.3 to 6.11.3.5.

Voltage drop on *unmetered* submains shall not exceed 2.5% of the supply voltage (voltage drop calculations must be included with the submission). (Refer to page 1 for contact details).

6.11.3.2 Meter Positions – Multiple Metering Points

Installations with multiple metering points as detailed in Clauses 6.11.3.3 and 6.11.3.4 are to have community metering (where required) located on the main switchboard.

6.11.3.3 High Rise Buildings

For buildings up to four floors, a single meter position on common property on the ground floor is approved.

For high rise buildings in excess of four floors, one meter position on every floor is approved.

6.11.3.4 Shopping Centres

For shopping centres, other than high rise buildings complying with Clause 6.11.3.3 above, an additional metering point for every twelve *customers* will be permitted.

6.11.3.5 Community (Strata/Group) Title and Cluster Developments

In general the *distributor* will provide one *connection point* to a community title scheme or cluster development installation. Unless otherwise approved by the *distributor*, all community metering shall be located at one position. Where additional Community

Metering points are approved, each shall be treated as a separate *NMI* (Refer to Drawing QECMM 6.5).

Where a cluster or community title scheme development consists of a number of multi-tenanted buildings, additional meter position/s located on common property may be permitted.

The following meter positions will also be acceptable:

(a) Overhead Reticulation

- (ii) The main switchboard located on *common property* and all metering equipment installed at this position.
- (iii) The main switchboard and the first metering point located on *common property* and subsequent metering points located on *common property* or as otherwise approved by the *metering provider*.

(b) Underground Reticulation

Arrangements given in either (i) or (ii) above: or

The individual *consumer's mains* (for each unit) installed on *common property* and connected to the *distributor's* reticulation with the metering equipment located at the unit.

Note: Where more than 3 sets of *consumer's mains* are to be connected to a distributor's pillar, approval must be obtained from the *distributor*

Note: A general arrangement is for twelve *customers* or units per metering point or as otherwise approved by the *distributor*.

The *Energex* Subdivision Standards - Developer Design & Construct Estates Manual provides further information regarding Community Title and Cluster Developments in the *Energex* distribution area. It is available for download on the *Energex* website.

6.11.4 Unsuitable Locations

The following locations are unsuitable for the installation of metering equipment:

- (a) Within or at any height above any pool zone as defined in AS/NZS 3000 (Wiring Rules).
- (b) Locations where the only point of access is through the fenced area around the pool.
- (c) Within any hazardous area defined in AS/NZS 3000 (Wiring Rules) or within a gas emitting device (gas meter regulator) exclusion zone defined by AS 5601-2004 (Australian Gas Code) and AS 4645.1. In particular, *electrical contractors* should be aware of the hazardous areas associated with exchange or in-situ fill LPG gas cylinders. (Refer to AS/NZS 3000 (Wiring Rules) and AS/NZS 2430.3.4).
- (d) Over stairways or ramps, in narrow passageways, toilets or fire isolated stairways.
- (e) In vehicle docks, driveways, factory walkways etc. where the equipment, or a person working on the equipment would not be adequately protected.
- (f) In close proximity to machinery.
- (g) Locations where exposure to fumes, dust or dampness may result in unsatisfactory working conditions.
- (h) In positions where the ambient temperature exceeds 50⁰ C (e.g. boiler rooms).

- (i) In areas with insufficient light.
- (j) In confined spaces.
- (k) In areas where the integrity of a security system will be affected by entry of the *metering provider's* personnel, (refer to Clause 6.15), or where access is normally restricted for health or other reasons.
- (l) In multiple installations, the meter position is not to be situated within any lockable portion of an individual tenancy (i.e. shall only be located in a common area).
- (m) Within enclosed carports or verandahs.
- (n) In areas enclosing dogs.
- (o) Behind a property perimeter fence without an adjacent gate. (Refer to Clause 6.11.2 for meter positions on domestic properties).
- (p) In areas subject to varying high intensity magnetic fields. (Refer to Clause 6.22 for current transformer meter panels in the vicinity of heavy current carrying conductors).
- (q) On the *distributor's* works. (For exception details refer to Clause 5.9).
- (r) Secured private areas.
- (s) Where the noise level exceeds the LAeq.8h level of 85dB(A) as per the Qld Health and Safety Regulation and Australian Standard AS/NZS 1269.1
- (t) In areas where the *distributor's* staff require inductions to access the site (permanent sites only, building sites/builders temporary supplies are exempt from this item). This item is a recommendation only and may not be possible in all instances.
- (u) Where access may require any additional provisions e.g. EWP or scissor lift to perform a rescue of an injured worker.

6.11.5 Existing Installations

Where work is performed on an existing installation, compliance with the following requirements must be satisfied;

Electrical Additions & Alterations (Major) - Where major upgrades are carried out to a *customer* installation (e.g. *consumer's mains* upgrade and/or meter enclosure replacement and/or replacement of a meter panel not housed in an enclosure) the location of the meters shall comply with all requirements of Section 6.

Note: refer also to clause 5.4.5 (d) for requirements to relocate overhead service *point of attachment* where major alterations are carried out.

Electrical Additions & Alterations (Minor) - Where minor upgrades are carried out to a *customer* installation (e.g. additional tariff or *MEGU* metering, load centre change, replacement of a meter panel within an enclosure where the enclosure is not being replaced) the meters may be left in the existing location, provided the metering location is suitable to the *metering provider* (refer to Clause 6.11.1 & 6.11.4 for unsuitable locations).

Building Renovations / Alterations - Where building alterations or similar works are carried out to *premises* which results in the metering equipment no longer being in a position that is suitable to the *metering provider* (refer to Clause 6.11.4 for unsuitable locations), the *customer* shall, at their expense, relocate the metering equipment to an acceptable position complying with Section 6.

Other Repairs & Damage caused outside a person's control (e.g. Natural Disaster) – Compliance with Section 6 is required where the metering is located in an unsuitable location (refer to Clause 6.11.4). In instances where the metering is not located in an unsuitable location, repairs may be carried out by “using methods that were acceptable when that part of the electrical installation was originally installed”, provided those methods satisfy the fundamental safety principles of Part 1 of AS/NZS 3000.

In addition to the above, all new or replacement metering panels shall also comply with Clause 6.14.

Only the appointed *Metering Provider* can work on or remove metering equipment. (Refer to responsibilities section).

6.12. Metering and Control Equipment - Housing

ASBESTOS WARNING

Older type switchboard and meter panels may contain asbestos. Electrical workers who are required to work on these panels need to identify if this hazard is present and, if necessary, take appropriate action. Old Zelemite (black) electrical switchboards can contain up to 20% asbestos. When working on an electrical switchboard that is aged (pre 1987), assume the presence of asbestos, even if it is not marked as such.

Asbestos information including codes of practice and legislative requirements is available on the Workplace Health and Safety Queensland web site www.deir.qld.gov.au/workplace/ under the heading “laws and prosecutions”.

6.12.1 Where meters and control equipment are erected in a position exposed to the effects of the weather, direct sunlight, corrosive atmosphere and the like they shall be enclosed in a suitable meter enclosure. Meter reading windows in meter enclosures are not permitted.

Meters, control equipment and their enclosures shall be protected from mechanical damage, by either their location or the manner of mounting.

Note: Where a meter enclosure is installed on a temporary structure, the supporting structure shall be mechanically sound. Where the temporary structure is used for building purposes it shall comply with the requirements of AS/NZS 3012 (e.g. includes the connection of permanent supply for domestic building purposes in a URD estate).

6.12.2 Where meters and control equipment are accessible only from the outside of a building, they shall be enclosed in a suitable meter enclosure mounted on, or recessed into the outside wall of the building. Meter enclosures shall not be installed where they protrude or open across a property boundary.

Exception: Meter enclosures mounted on the front boundary may open towards the footpath. It is recommended that meter enclosures mounted in these positions be locked. (Refer to Clause 6.15 for metering lock details).

On a single *direct connected metering* installation a meter enclosure shall comply with either: "Specification for Metallic Enclosures for Meters in Direct Connected

Installations" QECMM Appendix A, or (at the discretion and written approval of the distributor) another type of metering enclosure complying with AS 6002.

6.12.3 Where a meter enclosure used to house revenue metering equipment is erected on a pole, it shall be constructed of an approved material (not timber), be adequately fixed in position and where necessary, suitably treated against corrosion.

6.12.4 All metallic meter enclosures shall be earthed. Where double insulation is maintained throughout the meter enclosure (in accordance with the requirements of AS/NZS 3000 (Wiring Rules)), earthing is not required.

6.13. Metering and Control Equipment – Spacing Requirements

Item A.3 of the "Specification for Metallic Enclosures for Meters in Direct Connected Installations" in Appendix A, specifies minimum space requirements for metering equipment on direct connected installations.

Clause 6.21 specifies minimum space requirements for meter panels for low voltage *current transformer metering*.

Minimum space requirements for mounting of meters and control equipment are shown in TABLE 6.1.

TABLE 6.1

Meter and Network Device Details	Height (mm)	Width (mm)	Depth (mm)	Approx. Weight (kg)
Single Phase Meter	255	150	130	1.5
Polyphase Meter	285	180	135	2.1
Network device	190	110	110	0.5
Metering Isolation Link	90	45		

A minimum clearance of 25mm is required between any item of metering or control equipment.

The minimum clearance around the ends of metering isolation links shall be 40mm minimum.

Exception: Metering isolation links associated with each NMI can be mounted side by side with no clearance between provided the minimum clearance around the ends of metering isolation links is 40mm minimum.

6.14. Metering and Control Equipment - Mounting

6.14.1 All meters, *network devices* and metering isolation links must be mounted on a side hinged panel so that the metering and control equipment always remains in the vertical plane. Meters and *network devices* must be mounted vertically with cable connections at the bottom (Refer to Drawing QECMM 6.1 and Appendix A).

Existing installations

Where *direct connected* meters are installed to facilitate a *customer* requested supply/tariff change, additional tariffs (e.g. controlled supply tariff) or installation of an *MEGU* on an existing single *customer* installation, allowance is also to be made for the metering equipment to be mounted on a hinged panel in accordance with Clause 6.14.1.

- 6.14.2** Meter panels shall be constructed of a durable, non-conducting, fire resistant material with low water absorption properties and shall not contain asbestos. Alterations requiring a replacement meter panel shall comply with the above. Existing meter panels in good condition do not require replacement however insulated fire retardant backing boards with low water absorption properties and not containing asbestos must be installed behind all new and retrofitted electronic equipment associated with the *customers* metering and control equipment on existing panels that are not constructed of fire resistant material.
- 6.14.3** Bolts/screws used to mount and fix equipment on insulated meter panels shall be fit for purpose. Where mounting bolts/screws protrude through the meter panel and can be contacted, a non-conducting bolt/screw (e.g. nylon or plastic) shall be used.
- Note:** Metal screws with needle points and self drilling tips are not permitted. The insulating of metal screws using silicone or other material is not permitted.
- 6.14.4** The panel within the meter enclosure should be not more than 300 mm from the front of the meter enclosure.
- 6.14.5** The meter panel is dedicated for revenue metering equipment and *network devices*. *Customer* owned equipment (including GPOs, Contactors etc) shall not be installed on the meter panel (this excludes metering isolation links/CBs as this equipment is part of the revenue metering). *Customer* owned metering neutral and active links should also be mounted on the rear of the meter panel or meter enclosure and shall not be mounted on the front of the meter panel (refer to Clause 6.7.6).
- Note: Where a larger panel is used, it is permissible for *customer* owned equipment to be installed on the same panel outside of an area dedicated for use for metering equipment provided the meter panel area meets the minimum size specified in Appendix A, is indelibly marked with a demarcation line and is labelled to indicate the meter panel section is dedicated for metering equipment
- Meter panels on temporary builder's supplies do not need to be dedicated to revenue metering equipment unless they are intended to be installed in the permanent position.
- 6.14.6** **Height of Metering and Control Equipment – Mounting Height**
- Unless otherwise approved in writing by the *distributor*, the top of any metering equipment shall have a maximum height of 2000mm above floor or ground level. The bottom of the meter, *network device* or item of metering equipment shall not be less than 900 mm above floor or ground level when not installed in an enclosure or dedicated switch room or meter room. This height may be reduced to 700mm (500mm for metering isolation links) above floor or ground level when installed within an enclosure or dedicated switch room or meter room.
- Where the *customer* is required to provide a platform to access a meter installation, it shall be designed to AS 1657, be certified by a RPEQ that the structure is suitable for the application, and be designed to support a minimum load of 200kg. A certificate of approval shall be submitted to the *distributor* prior to connection of

supply. Where meters and switchboards are installed on service poles, the platform shall be self-supporting and permanently mounted.

The service pole shall not be used to support any platform structure, and any step-type ladder access shall be clear of any fences or sharp objects that may be considered a fall hazard.

For clearances in front of the metering enclosure doors refer to AS/NZS 3000 (Wiring Rules) (i.e. minimum clearances of 600mm).

For existing installations where access is considered unsafe, the *metering provider* may refuse to read the meters until the unsafe condition has been rectified by the *customer* or may repair the access at the *customer's* cost. (Electricity Regulation 2006).

6.15. Metering Locks

Where the *distributor* agrees to meters being erected in an enclosure within an area which may be locked for security reasons, or where meters may be subject to vandalism, the *distributor's* metering lock must be purchased and installed to permit access. (Refer to page 1 for purchasing details and Drawing QECMM 6.6 for lock types). The installation of "Private Locks" is not permitted for providing access to metering equipment.

Where the *distributor's* metering lock is installed, all tenants who require access to the meter panel shall be provided with such access.

Note: If the *distributor's* personnel are requested to open the metering lock for tenant access, the *customer* will be charged a call out fee.

Metering locks shall not be used on a garage door, verandah door or similar doors that provide access to private areas. (Refer to Clause 6.11.4 and Drawing QECMM 6.6).

The *distributor* may provide master metering lock keys to *metering providers* when requested in accordance with their procedures. *Metering providers* will keep master keys secure and return them to the *distributor* when no longer required or when requested by the *distributor*.

6.16. Current Transformer Metering - General Requirements

The following procedures are to be adopted when assessing the metering requirements, for new installations or additional load for an existing installation, and arranging for the installation of *current transformer metering*.

In general, calculated loads greater than 120A per phase or actual loads greater than 90A per phase will require current transformer metering. Contact the *metering provider* for further information.

6.17. Current Transformer Equipment supplied by the Distributor

The *distributor* will supply the current transformers, E.S.A.A. pattern test block, voltage circuit fuses with HRC cartridges and fuse sealing blocks with covers. *Energex* provides current transformer ratio and neutral identification labels for use in their area. The *metering provider* will provide the meter and/or communications equipment.

6.18. Current Transformer Selection

In general the standard current transformers supplied by the *distributor* or the *metering provider* are E.S.A.A type "S", "T" and "W".

TABLE 6.2 below details the type, ratio and accuracy range of current transformers supplied.

TABLE 6.2

TYPE OF CT	CT RATIO	CLASS (AS 60044)	ACCURACY RANGE OF CT (AMPS)	MAX. 3 PHASE LOAD (kVA)	MAX. SINGLE PHASE LOAD (AMPS)
S (long range)	200/5	0.5S ext 200%	2 - 400	250	350
T (long range)	800/5	0.5S ext 200%	8 - 1600	1000	1400
W (long range)	1500/5	0.5S ext 200%	15 - 3000	2000	3000

6.19. Current Transformer Metering - Housing

6.19.1 On new installations and where major alterations are to be carried out, each set of current transformers and meter voltage fuses are required to be mounted in a separate dedicated metering chamber. This chamber is to enclose only the *metering provider's* equipment. (Refer to Drawing QECMM 6.7).

In general, each current transformer chamber is a dedicated chamber for one NMI and as such, no other equipment or wiring is permitted in or to pass through the chamber, however, cables enclosed in a continuous metal duct located in a back corner of the current transformer chamber are permitted. (Refer to TABLE 6.4).

6.19.2 Current transformer chambers shall be labelled to indicate the presence of the revenue metering current transformers and access panels shall have provision for sealing. The electrical contractor or switchboard manufacturer shall supply and install labels stating "Revenue Metering Current Transformers" on current transformer chambers.

6.19.3 To allow commissioning and testing of *current transformer metering* installations to be performed safely, all live low voltage parts within current transformer chambers are to be individually insulated (insulation must completely cover all live parts). Heat shrink insulation is acceptable for insulating busbars. All bolted busbar or cable connections are to be covered with non-adhesive insulation secured in place by cable ties.

A non-conductive insulated barrier alone (removable cover over CT chamber) is not an acceptable method of insulation.

6.19.4 Where a removable cover is used to enclose the dedicated metering current transformer chamber it shall be fitted with a minimum of two handles to allow safe removal without disconnecting supply. This requirement does not apply to hinged covers. Locks are not permitted as a means of securing current transformer chambers due to the difficulty in obtaining access. (Refer to Clause 6.5 for sealing requirements).

6.19.5 Entry and exit holes in the current transformer chamber for primary wiring and secondary current transformer meter wiring shall be provided with suitable grommets or bushings to protect the conductor insulation or sheathing. Holes shall

be sized for the passage of these conductors only. (Refer to AS/NZS 3000 (Wiring Rules)).

6.19.6 The minimum space to mount and gain access to current transformers is shown in TABLE 6.3. Drawing QECMM 6.7 shows typical arrangements for the equipment within the current transformer chamber.

Fuse blocks may be mounted on the side of the enclosure provided the minimum clearances to busbars and live parts are maintained for safe removal of fuses.

Busbars or cables shall be evenly spaced to facilitate current transformer removal and replacement.

A minimum clearance of 20mm is required around each current transformer with a minimum clearance of 70mm between the CTs and the bolts securing the removable section of busbar.

TABLE 6.3

Type of CT	In Line Mounting		Staggered Mounting	
	Min. Width of Opening Dim. "a" Dia. 1 (mm)	Min. Width of Opening Dim. "b" Dia. 1 (mm)	Min. Width of Opening Dim. "a" Dia. 2 (mm)	Min. Width of Opening Dim. "b" Dia. 2 (mm)
S (200/5)	470	350	385	450
T (800/5)	575	400	495	500
W (1500/5)	650	450	570	550

6.19.7 To gain access to any current transformer or voltage circuit fuses it shall not be necessary to interrupt supply to a *customer*.

6.20. Current Transformer Metering – Installation Requirements

6.20.1 Current Transformers

6.20.1.1 For general dimensions and mounting of current transformers for correct polarity refer to Drawings QECMM 6.8.

6.20.1.2 Current transformers shall be installed in a manner that facilitates replacement and mounted with suitably sized bolts, nuts and washers (self tapping screws are not permitted). A readily removable section of busbar as shown in Drawing QECMM 6.7 shall be provided within the current transformer chamber.

6.20.1.3 The current transformer secondary terminals shall be readily accessible and between 500mm and 1800mm from floor or ground level to allow access to terminals without undue risk to personnel when the switchboard is live.

6.20.2 Voltage Circuit Fuses

6.20.2.1 Voltage circuit fuses shall be mounted in such a manner that the fuse carriers may be removed, replaced and sealed without undue risk to personnel when

the switchboard is live (generally facing the front of the chamber). (Refer to Clause 6.19.6 and Drawing QECMM 6.9).

6.20.2.2 A sealable fuse mounting block with HRC fuse cartridges shall be used on all new work and when upgrading existing installations. (Refer to Drawing QECMM 6.9).

6.20.2.3 The voltage circuit fuses shall be connected in such a manner that the energising current of the meter voltage coil will not be registered through the current transformers (i.e. should be connected to line side of the current transformers).

6.20.2.4 The supply conductors to the voltage circuit fuses shall be as short as practicable, in no case exceed 500mm in length, be separated from bare live busbars and shall originate from within the current transformer chamber. The conductors shall be double insulated and a minimum of 10mm² stranded cable of not more than 7 strands. No joints are permitted in these conductors. Where colour coded cables are unavailable, colour coding shall be provided by the use of appropriate coloured sleeving at both ends with a minimum length of 150mm at each end. (Refer to Drawing QECMM 6.10).

6.21. Current Transformer Metering – Meter Panels

6.21.1 In general, meter panels for current transformer metering shall be installed remote from the switchboard. A separate meter panel is required for the metering equipment of each NMI.

Exception: Approval will be given for panels to be mounted within switchboards provided the:

- (a) Switchboard is readily accessible. (Refer to Clause 6.11); and
- (b) The meter panel is dedicated for revenue metering equipment for that NMI; and
- (c) The meter panel is shielded and/or sufficiently spaced from electromagnetic fields (refer to Clause 6.22); and
- (d) No panels or equipment (including meter panels) shall be mounted in front of the current transformer chamber.

Note: *Direct connected meter* wiring is permitted behind or on a current transformer meter panel provided it is for a secondary supply meter associated with the same *customer* (i.e. for the same *NMI*). All *direct connected meter* wiring behind the meter panel shall be separated and segregated from the current transformer meter wiring by enclosure within an earthed metal conduit, trunking or duct.

6.21.2 Unless otherwise approved by the *distributor*, a hinged panel with minimum dimensions of 600mm x 600mm shall be provided for the mounting of meters and metering test block on the same vertical surface. (Refer to Drawing QECMM 6.11).

Exception: For single supply current transformer metered installations, meter panels with minimum dimensions of 600mm high X 460mm wide are permitted.

Unless specifically approved by the *distributor* no *customer's* equipment or wiring shall be permitted within the meter panel enclosure. (Refer to Drawing QECMM 6.11).

6.21.3 The panel shall be hinged on a vertical edge such that the panel can be opened at least 90° with the meters mounted. (A double offset hinged section may be required).

6.21.4 Meter panels shall be constructed of durable, non-conducting fire resistant material with low water absorption properties and shall not contain asbestos.

6.21.5 Meter Panels are required to have provision for sealing.

6.21.6 Clearances Required for *Current Transformer Metering* Panels

6.21.6.1 The clearance from the back of the meter panel to the back of the enclosure shall be a minimum of 75mm.

6.21.6.2 Where meters are enclosed, the clearance between the front of the meter panel and the back of the closed door (including any hat section) shall be not less than 175mm.

6.22. Spacing between Meters and Heavy Current Carrying Conductors

6.22.1 The presence of external magnetic fields from nearby heavy current carrying conductors can cause errors in meter registration. To ensure maximum accuracy of the metering installation it is necessary to take adequate precautions against the effects of external magnetic fields.

6.22.2 Grouped Conductors

There are no special requirements for spacing or shielding where the current is carried by a three phase cable or three single core cables in a trefoil formation.

6.22.3 Separated Conductors

Where conductors of a circuit are physically separated, as in spaced single core cables or busbars, meters/meter must be suitably spaced from the conductors to reduce the effect of the magnetic field.

Where spacing alone cannot be achieved, magnetic shielding of suitable thickness may be used to reduce the minimum clearance by enclosing the conductors in a mild steel pipe or duct or enclosing the meters/meter wiring within a mild steel enclosure. Stainless steel, some alloy steels, aluminium, copper and other non-ferrous metals are not suitable materials for magnetic shielding.

The minimum spacing between revenue meters/meter wiring and conductors carrying heavy currents shall be derived from TABLE 6.4 - intermediate points may be obtained by interpolation.

TABLE 6.4

Conductor Current (A)	Min Spacing (mm)			
	No Shielding	Thickness of Shielding (mm)		
		1.2	2.5	5.0
Up to 150	100	-	-	-
400	500	375	250	125
600	700	525	350	175
1000	900	675	450	225
1500	1200	900	600	300
2000	1400	1050	700	350
3000	1700	1275	850	425
4000	2000	1500	1000	500

Note: Where the above spacing cannot be maintained within the switchboard, it is expected that the meter panel be installed remote from the switchboard. Particular care should be taken when the switchboard is constructed of aluminium or stainless steel.

6.22.4 Under no circumstances shall current transformer meter wiring be grouped with other conductors. Meter wiring run externally to the switchboard enclosure shall be contained within a separate conduit or cable trunking. (Refer to Clause 6.22.3 and 6.23.3.5).

Each individual set of current transformer meter wiring installed behind a meter panel containing multiple groups of current transformer meters, shall be grouped and separated from the other sets of current transformer meter wiring.

6.23. Current Transformer Metering – Additional Requirements

6.23.1 For all *current transformer metering* (unless an agreement has been negotiated with the *metering provider*), the *electrical contractor* is responsible for the:

- (a) Supply of the meter panel.
- (b) Mounting of the meter panel.
- (c) Mounting of the current transformers.
- (d) Mounting of the voltage fuse block.
- (e) Mounting of the test block.
- (f) Supply and installation of all secondary wiring between the current transformers, test block and meter, including the voltage supply.
- (g) Wiring of the meter panel (surface wiring of meter panels is not permitted).

Current transformers, metering test block, voltage circuit fuses and fuse sealing block will be made available to the *electrical contractor* to install.

To obtain LV *current transformer metering* equipment, *electrical contractors* are required to submit a CT Metering Equipment Order Form that is available from the *distributor's* web site. (Refer to *distributor's* contact details page 1).

Once this form has been approved, LV *current transformer metering* equipment can be issued to the *electrical contractor*.

Energex: LV *current transformer metering* equipment will be issued over the counter directly to the *electrical contractor* from the major depots listed on the CT Metering Equipment Order Form.

Ergon Energy: LV *current transformer metering* equipment can be issued either over the counter directly to the *electrical contractor* from the major depots listed on the CT Metering Equipment Order Form or by mail order to the address supplied on the form.

Where the metering is more complex than a standard installation the *electrical contractor* shall consult with the *metering provider*. The contractor may be required to deliver a suitable metering panel to the *metering provider* for wiring and testing prior to being delivered on site.

Note: Paralleling and summation of *current transformer metering* is not acceptable as it compromises total metering accuracy.

6.23.2 Current Transformer Metering Test Block

6.23.2.1 A test block supplied by the *distributor* shall be incorporated in all installations with current transformer metering. (Refer to Drawing QECMM 6.12).

6.23.2.2 The test block shall be mounted immediately below, and in the same plane as the current transformer meter, such that the voltage connection terminals are on the right hand side when viewed from the front of the test block. (Refer to Drawings QECMM 6.10 and 6.11).

6.23.2.3 Connecting wiring shall be enclosed under the test block cover (surface wiring is not permitted).

6.23.3 Wiring to Current Transformers, Test Blocks etc.

6.23.3.1 The connections and colour coding shown in Drawing QECMM 6.10 shall be the standard. Where multi-core cables are used for special site requirements (e.g. armoured cables required) the cores must be individually identified

Where single insulated grey coloured cable is not available one of the following arrangements may be used:

(a) single double insulated (SDI) cable no larger than 6mm² with grey coloured sheathing; or

(b) black single insulated conductors sleeved at both ends with not less than 300mm of grey coloured sleeving.

6.23.3.2 All voltage and current meter wiring (other than voltage circuit fuse supply conductors referred to in Clause 6.18.2.4) shall be PVC insulated stranded cable of no more than 7 strands. No joints are permitted in these conductors.

6.23.3.3 Where 2.5mm² conductors are used the bare ends shall be doubled over prior to connection to the current transformers and test block to facilitate a secure connection to the terminals.

6.23.3.4 The insulation on all voltage and current meter wiring should be stripped back 15mm (30mm where doubled up 2.5mm² is used) to ensure terminal screws make positive contact with the bare conductor. It is essential that terminal screws are connected securely to the bare conductors and not to the insulation of the wiring.

6.23.3.5 All current transformer wiring shall be enclosed in a continuous conduit, cable trunking or earthed metal duct from the current transformer chamber to the metering enclosure.

6.23.3.6 Current transformer metering secondary wiring shall be earthed as shown in Drawing QECMM 6.10. The earth conductor shall be connected directly to the main earth conductor or earth bar and not to a separate earthed medium such as the switchboard frame.

6.23.3.7 The earthing conductor shall be PVC insulated stranded cable of no more than 7 strands and can be 2.5mm² cable for all current transformer metering installations.

6.23.3.8 A meter neutral label shall be attached to the meter neutral conductor adjacent to its connection to the main neutral. (Refer to Clause 6.7.2 for metering neutral conductor connection details).

6.23.3.9 Cable tails through meter panels should have a minimum length of 150mm to allow for connection into the meters. Current transformer meters will be erected and connected by the *metering provider's* personnel only.

6.23.3.10 All current transformer metering, wiring and installations are to be completed in accordance with the wiring diagrams in this manual.

6.23.3.11 To ensure compliance of the current transformer metering, contractors should use the Electrical Contractor's LV CT Metering Check Sheet. This form

can be changed to include the contractor's logo and be part of the contractor's quality system. Additional checks can be included if considered necessary.

6.23.4 Changes to Existing Current Transformer Metering Installations

When all or part of the existing metering installation requires changing (e.g. upgrading of a switchboard, change to the type of supply), the *metering provider* may require the total metering installation, including current transformers, to be upgraded to comply with the requirements of this manual and the *National Electricity Rules*.

6.23.5 Changes to Existing Current Transformer Metering Installations

Ergon Energy requires **all** LV *current transformer metering* installation designs to have prior approval for the metering arrangement. This requires the submission of Switchboard Layout and Single Line Diagrams as early as possible to allow design modifications to be carried out if necessary prior to switchboards being built.

If this information is not provided *Ergon Energy* cannot guarantee supply will be connected if the switchboard does not comply.

This requirement arises from the distances between sites in the *Ergon Energy* area of supply. Early submission of drawings will assist in reducing the time and costs for all parties and avoid late modifications of *current transformer metering* switchboards.

QLD Electricity Connection and Metering Manual



Part of the Energy Queensland Group

Electrical Contractor's LV CT Metering Check Sheet			
Address Where CT Metering Installed:			
National Metering Identifier (NMI) (If known):			
Details of Electrical Mechanic Responsible for Testing of CT Installation:			
Name: Licence No:			
Pre-commissioning Checks			
Clause No.	Checklist	Checked	Comments
Switchboard/CT Chamber			
6.6.3	Lockable isolator on line side of CTs:		
6.19.1	Dedicated CT chamber provided:		
6.19.2	CT chamber correctly labelled:		
6.19.4	Removable CT chamber cover fitted with 2 handles:		
Current Transformers			
6.18	CT ratio matches expected load:		
6.19.3	No exposed live parts within CT chamber:		
6.20.1.1	Primary and secondary polarity is correct:		
6.20.1.1	Removable bus bars allow CTs to be easily replaced:		
6.20.1.2	CT secondary terminals are accessible:		
Voltage Circuit Fuses			
6.20.2.1	Fuses carriers are accessible and easily removable:		
6.20.2.3	Fuses are connected to the line side of the CTs:		
6.20.2.4	Cables from bus bars to fuses are $\leq 500\text{mm}$ and a minimum of 10mm^2 SDI:		
6.20.2.4	Correct marking of cables from bus bars to fuses (e.g. trace or bell out cables):		
Meter Neutral & Earthing			
AS/NZS 3000	Test continuity to confirm that cabinets are earthed:		
6.23.3.8	Meter neutral is connected to main neutral and meter neutral label is attached:		
Meter Panel Wiring & Test Block			
6.11.4	Meter panel located in suitable location		
6.21.2	Meter panel size is minimum 600 x 600mm (or 460 x 600mm for single tariff CT installation):		
6.14.6	Meters are mounted at correct height:		
6.21.3	Meter panel is hinged:		
6.22	Meters and wiring spaced from heavy current carrying conductors:		
6.23.2.2	Test block is mounted correctly:		
6.23.3.1	Colour coding is correct:		
6.23.3.2	Meter wiring is correct size for circuit length:		
6.23.3.6	Secondary returns are starred and earthed:		
Sealing			
6.5	CT chamber, voltage circuit fuses and meter panel are sealable:		

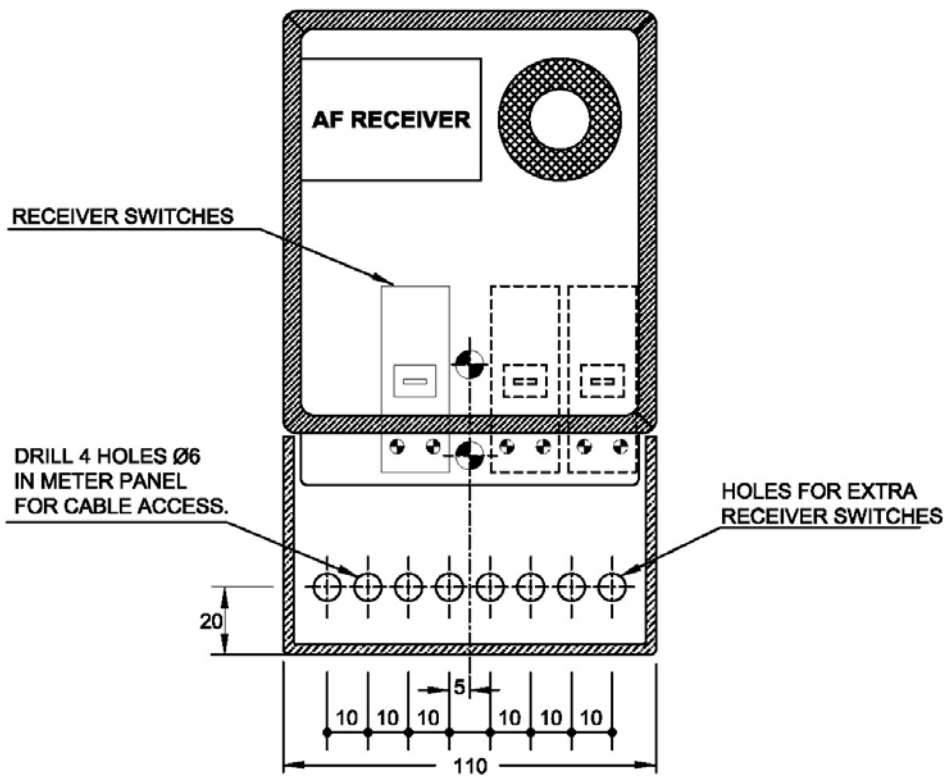

<p>Revision: A</p>	<p>DRILLING DETAILS FOR CABLE ACCESS AF RECEIVER</p>	<p>QECMM - 6.1</p>
-------------------------------	---	---------------------------

METERING ISOLATION LINK

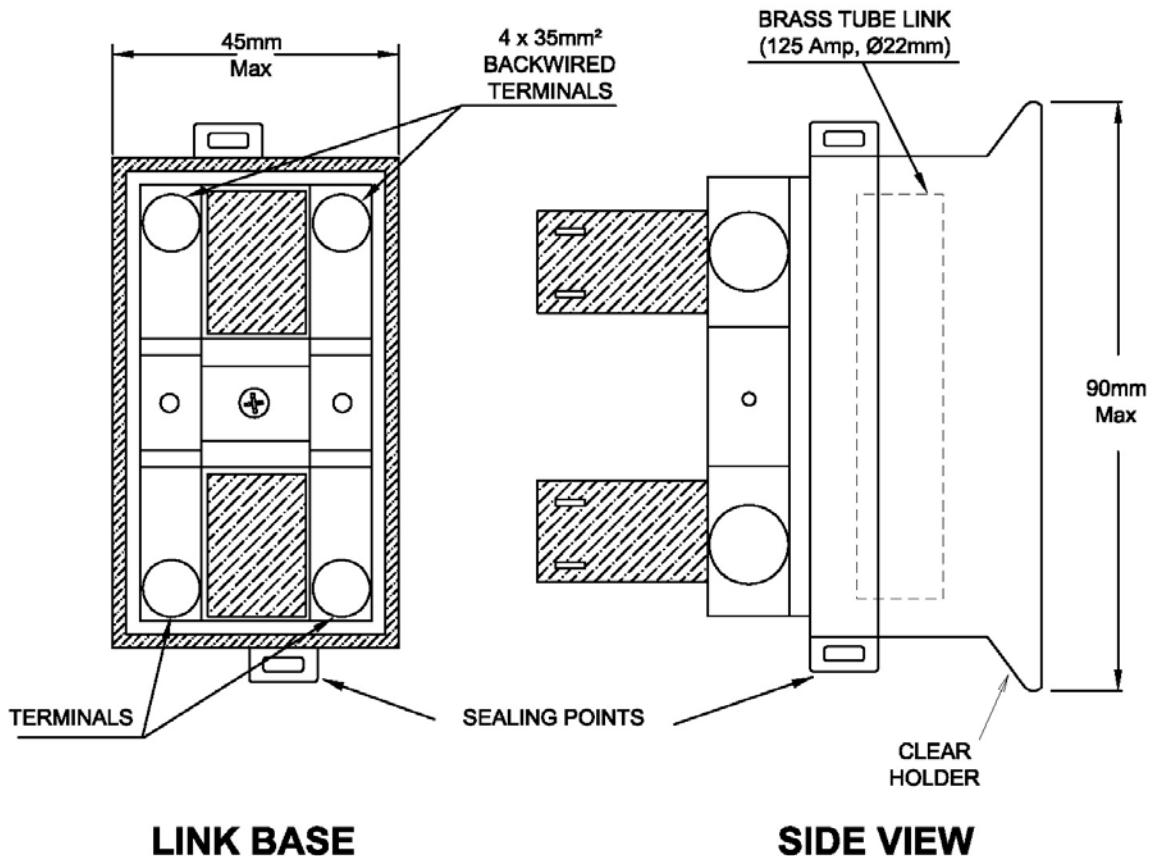

NOTES:

1. USE APPROVED METERING ISOLATION LINK, SUPPLIED WITH A 125 AMP BRASS TUBE LINK AND INSTALLED ON THE FACE OF THE METERING PANEL.
2. FOR POLYPHASE METERING - THE THREE METERING ISOLATION LINKS ARE TO BE GROUPED TOGETHER.
3. IT IS RECOMMENDED THAT THE METERING ISOLATION LINKS ARE MOUNTED HORIZONTALLY UNDERNEATH THE METER.
4. CLEARANCE OF 40mm TO BE LEFT AT EACH END OF LINK TO FACILITATE SEALING.

Revision: A	GENERAL DIMENSIONS METERING ISOLATION LINK	QECMM - 6.2
------------------------------	---	--------------------

QLD Electricity Connection and Metering Manual



Part of the Energy Queensland Group

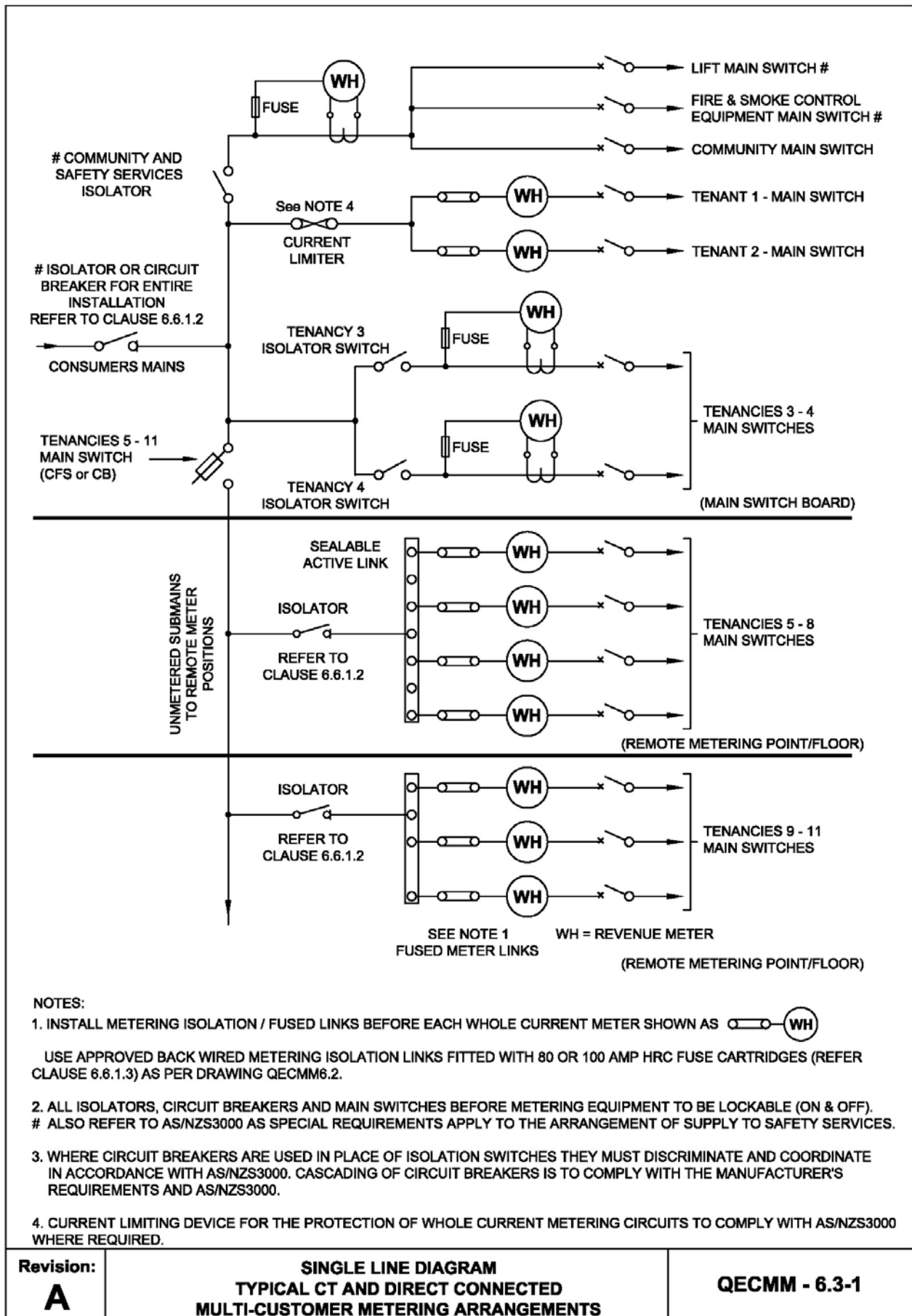

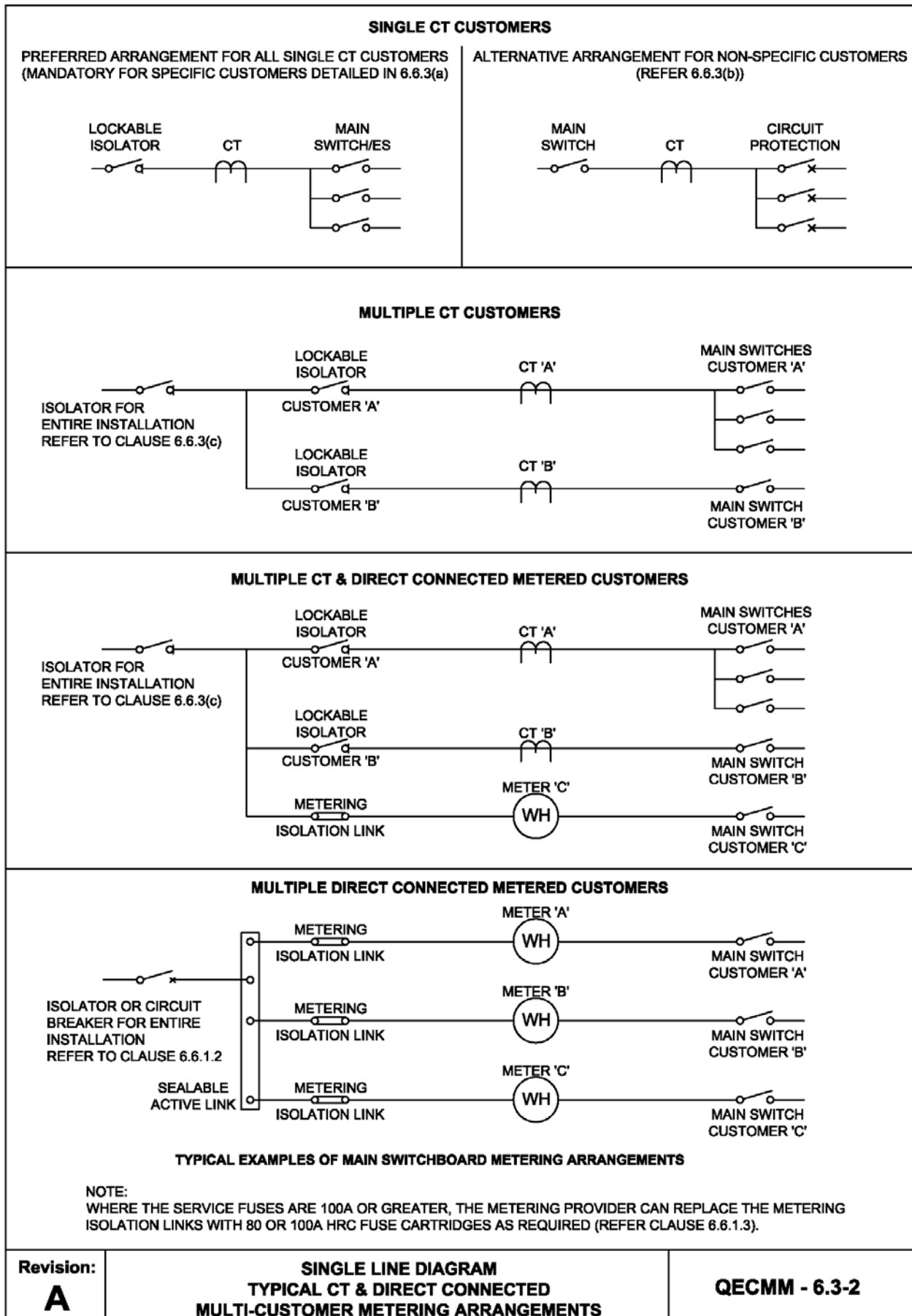

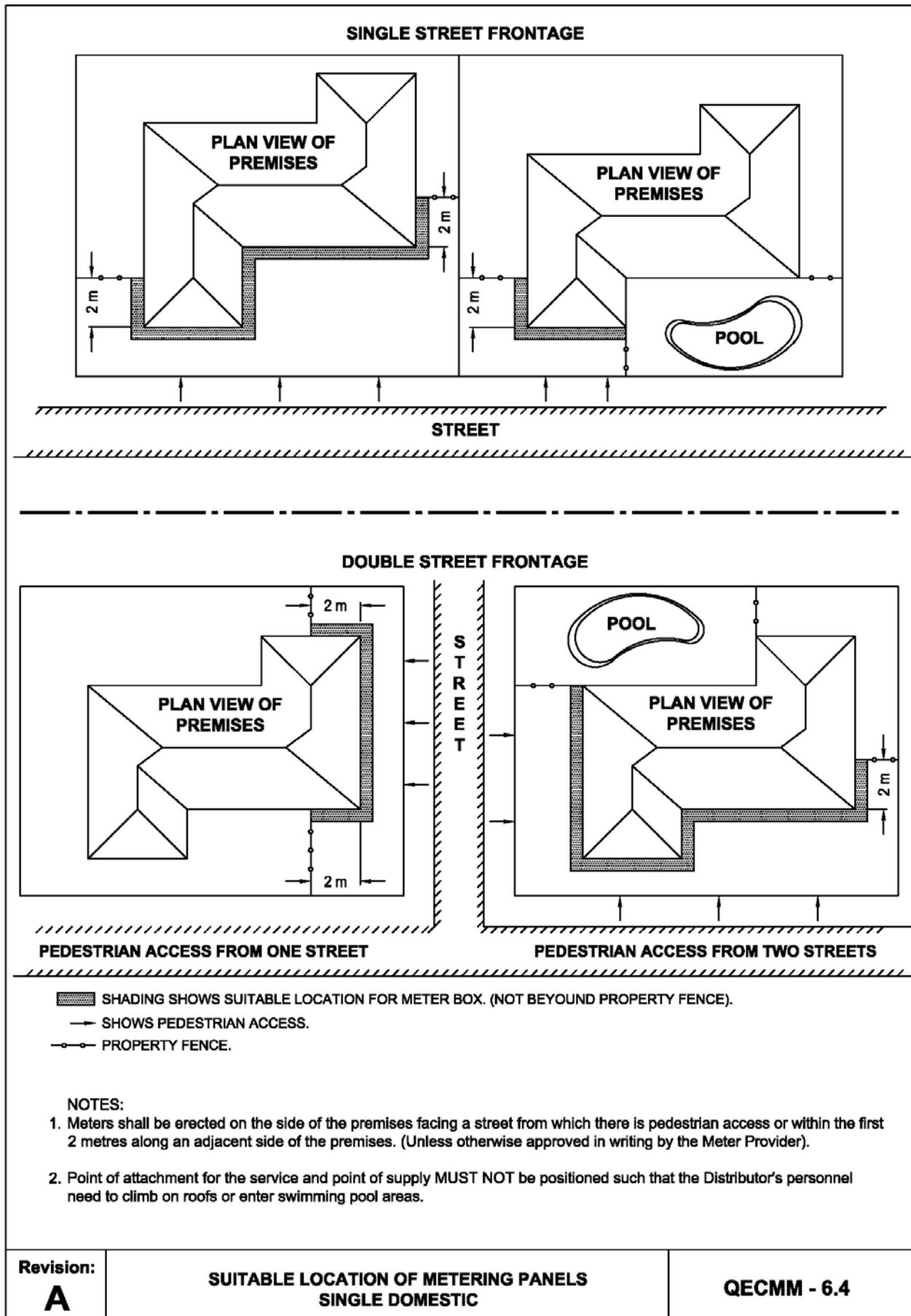

QLD Electricity Connection and Metering Manual



Part of the Energy Queensland Group

OH/UG	Community Title Scheme / Multi unit dwellings	Customer Reticulated community title schemes	Distributor's Reticulation community title schemes	Single unit dwellings
Meter Position	1 meter position on common property	The MSB and first meter position on common property plus 1 additional Meter position for every additional 12 customers if required	1 meter position per dwelling fed from the point of supply	1 meter position per unit
Point of Supply	1 Point of supply per community title scheme	1 Point of supply per community title scheme	1 Point of supply per unit	1 Point of supply per unit
	refer DWG A (I), (II).	refer DWG C	refer DWG D	refer DWG E

NOTES:

1. Common Property made exclusive use. DWG B

Where the area of common property has been designated for the exclusive use to each lot, ie. Fenced off and prohibiting access to other owners or occupiers to their metering position, service line and/or consumers terminals.
A separate point of supply & metering position shall be required for each unit and conform to Clause 6.11.4.

Under no circumstances shall the service line or consumers mains be permitted to cross or enter the area of exclusive use in order to service another lot.





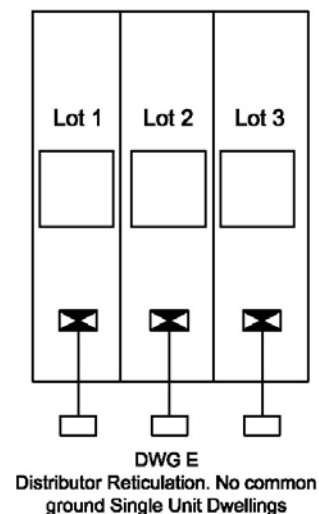
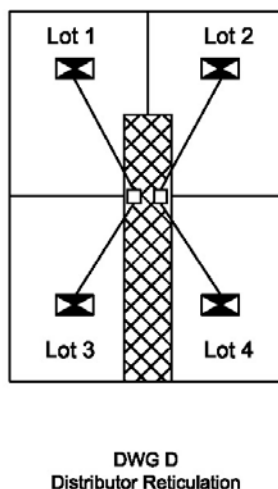
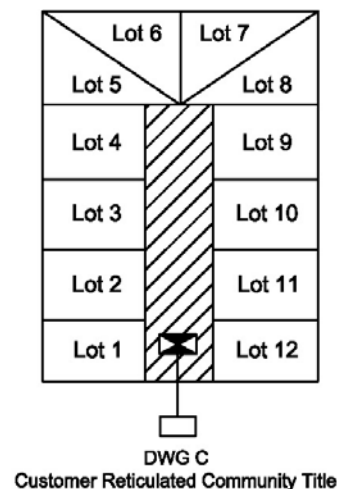
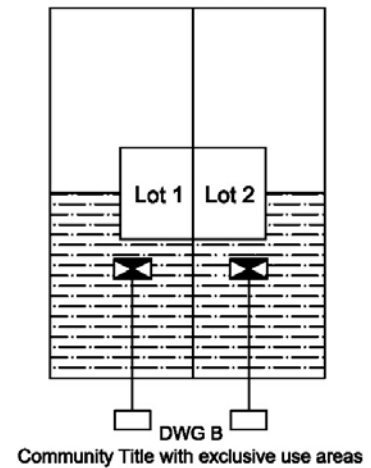
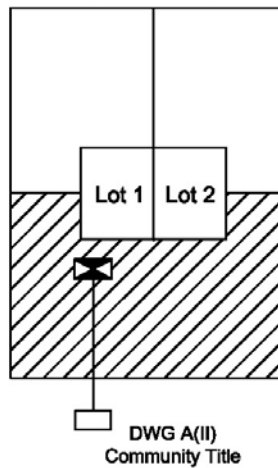
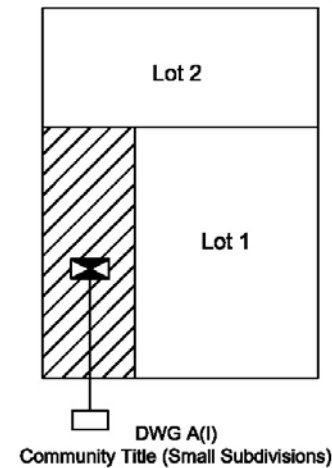

2. Dual occupancy developments shall only be entitled to have one point of supply and one metering position. ie. Granny flats, sheds, dependant persons accommodation.

Note: Point of supply and metering positions shown on diagrams are indicative only.

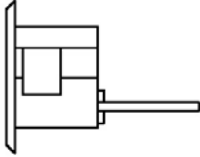
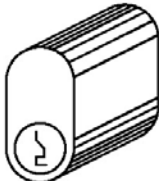
Point of supply
 Common Ground
 Metering Position
 Street/Laneway
 Exclusive Use Area

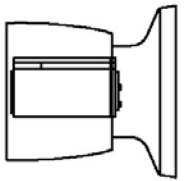

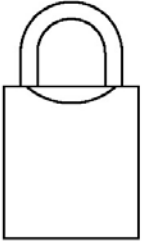
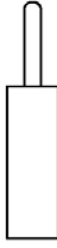
Revision: A	SUITABLE LOCATION OF METERING PANELS COMMUNITY TITLE	QECMM - 6.5
------------------------------	---	--------------------

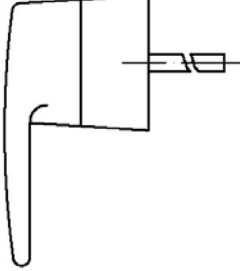
RIM LOCK CYLINDER		
		<p>TYPE 201 CYL FOR USE IN NIGHTLATCH/STREAMLATCH/DEADLATCH TYPE LOCKSETS. (CYLINDER ONLY PROVIDED.)</p>
MORTICE LOCK CYLINDER		
		<p>TYPE 570 CYL FOR USE IN CYLINDER MORTICE LOCKS AND LATCHES. (CYLINDER ONLY PROVIDED.)</p>
KEY - IN - KNOB CYLINDER		
		<p>TYPE 530 CYL FOR USE IN KEY-IN-KNOB AND KEY-IN-LEVER LOCKSETS. (CYLINDER ONLY PROVIDED.)</p>
BRASS PADLOCK		
		
<p>TYPE 234 FOR USE IN ERGON ENERGY TYPE 234/SS FOR USE IN ENERGEX</p> <p>234/45/119 - 19mm SHACKLE 234/45/138 - 38mm SHACKLE 234/45/148 - 48mm SHACKLE 234/45/190 - 90mm SHACKLE</p> <p>(COMPLETE LOCK PROVIDED.)</p>		
METER CUBICLE LOCK		
		<p>TYPE 'L' HANDLE OR 'T' HANDLE TO BE USED AS A METER CUBICLE LOCK. (COMPLETE LOCK PROVIDED.)</p> <p>NOTES: 1. USE 'EX' PREFIX TO INDICATE ENERGEX METERING KEY SYSTEM EG ENERGEX RIM LOCK CYLINDER USE TYPE EX201 CYL. 2. A LIST OF APPROVED LOCKSMITHS IS AVAILABLE ON THE DISTRIBUTORS WEBSITE - SEE CONTACTS PAGE FOR DETAILS.</p>
Revision: A	MASTER KEYED METERING LOCK DETAILS	QECMM - 6.6

TYPICAL ENCAPSULATED
CURRENT TRANSFORMER
TYPE S, T & W.

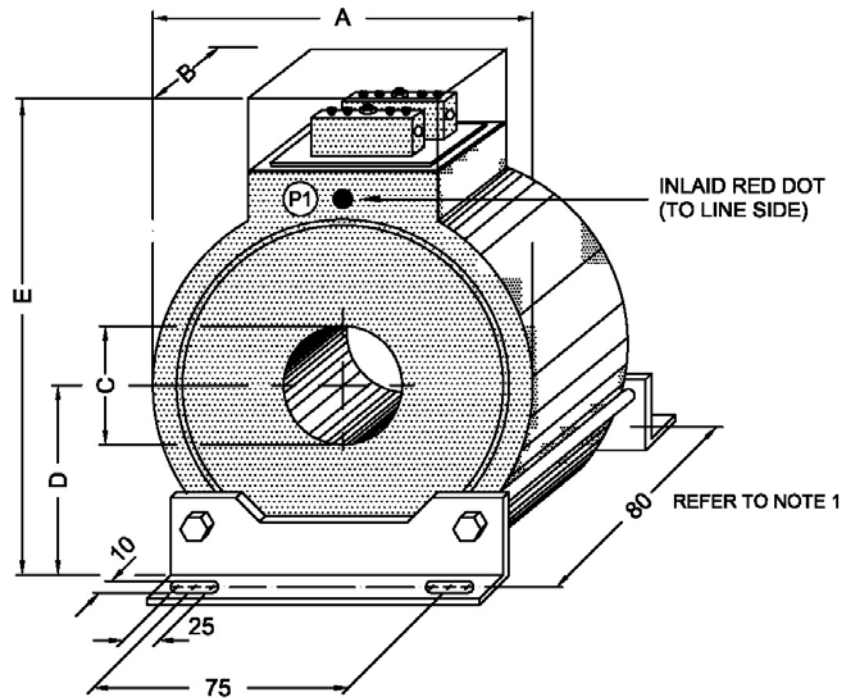

C.T. DESIGNATION	MAX. WIDTH A	MAX. THICKNESS B	WINDOW DIAMETER C	POSITION OF WINDOW CENTRE D	MAX. HEIGHT E	CT. RATIO
S	130	70	45	65	180	200/5 0.5S ext 200%
T	165	65	80	85	210	800/5 0.5S ext 200%
W	170	65	112	85	220	1500/5 0.5S ext 200%

NOTES:
1. ERGON 200/5, 85mm DIMENSION REQUIRED

Revision:

A

**GENERAL DIMENSIONS
METERING CURRENT TRANSFORMERS**

QECMM - 6.8

3Ø FUSE SEALING BLOCK

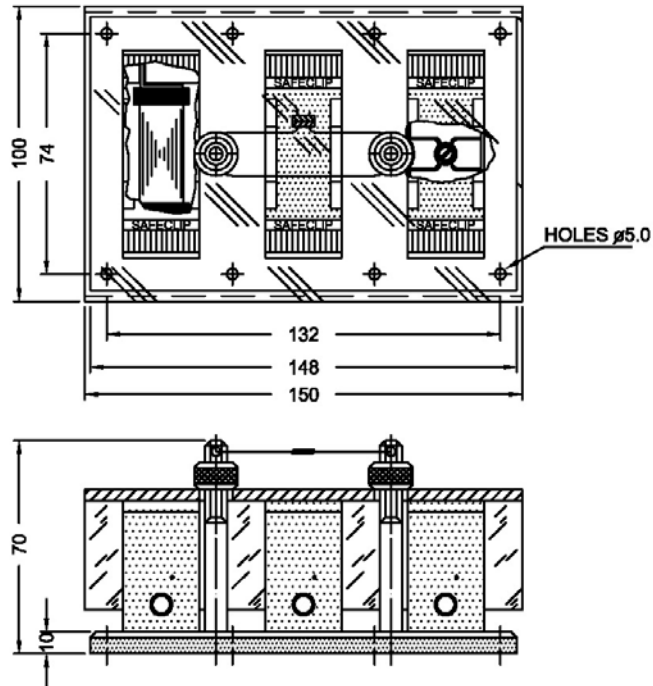

SINGLE FUSE SEALING BLOCK

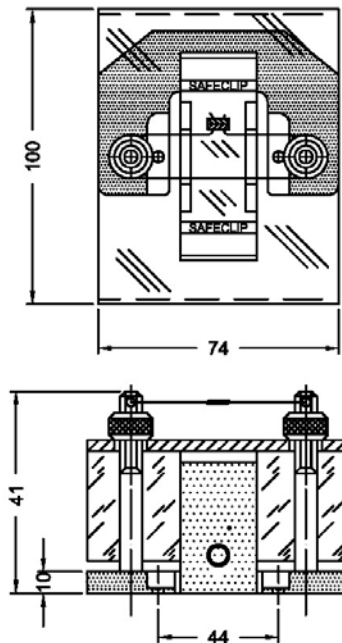

Revision:

A

**GENERAL ARRANGEMENT
METERING FUSE SEALING BLOCKS**

QECMM - 6.9

QLD Electricity Connection and Metering Manual



Part of the Energy Queensland Group

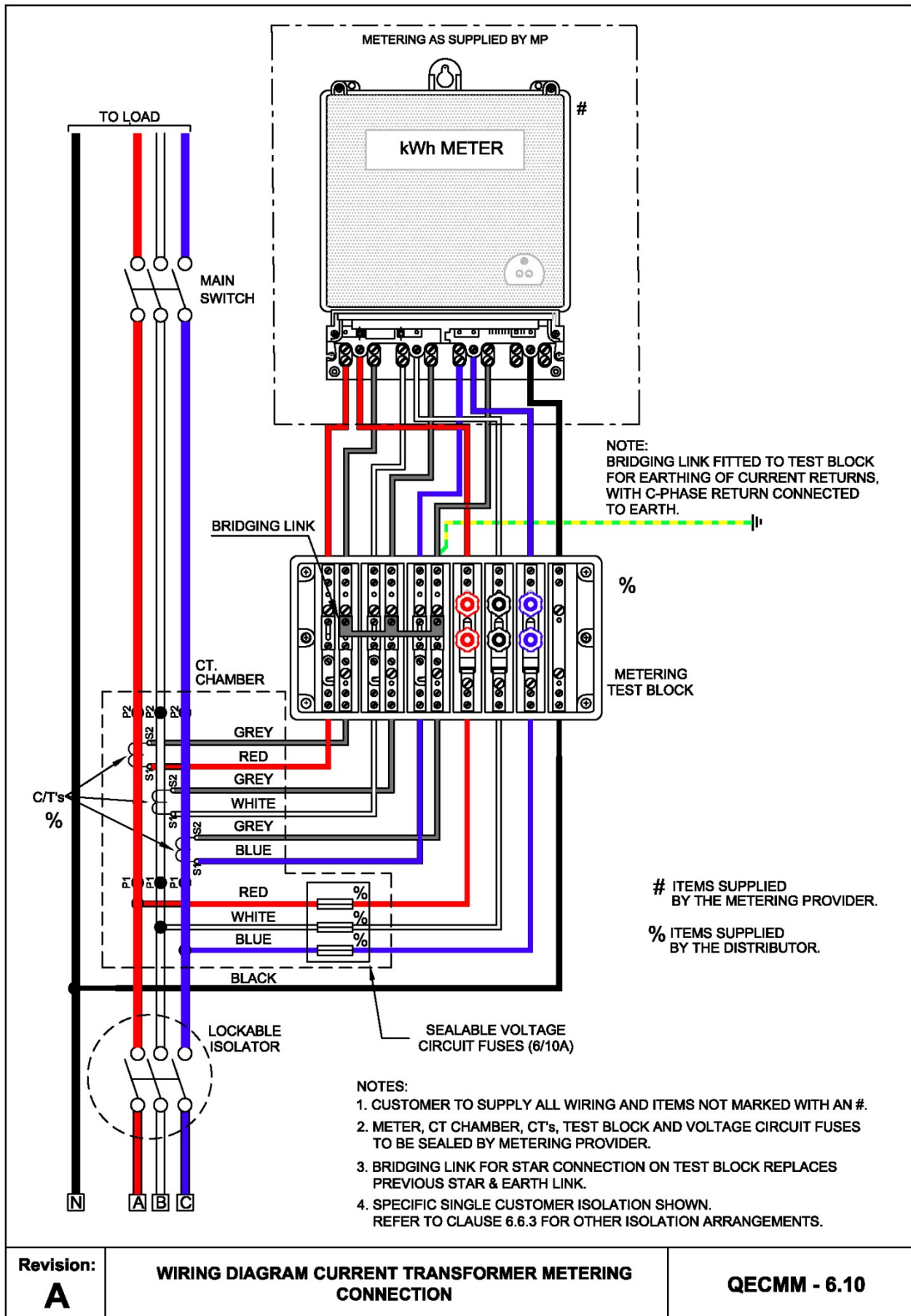

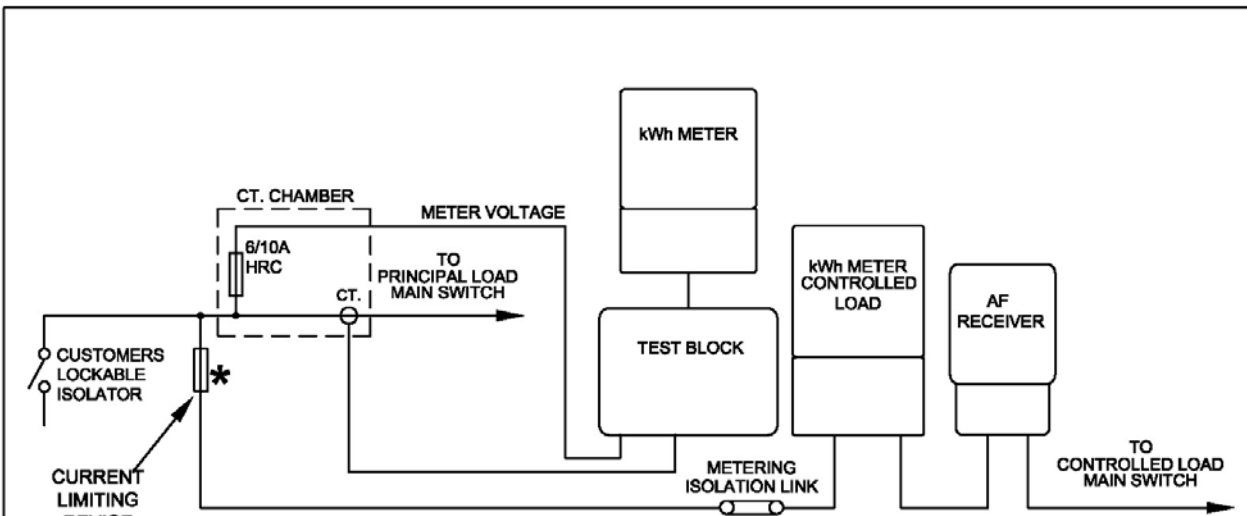

NOTES:

1. * CURRENT LIMITING DEVICES FOR THE PROTECTION OF WHOLE CURRENT METERING CIRCUITS SHALL COMPLY WITH AS3000 AND IN NO CASE SHALL BE RATED GREATER THAN A 100A HRC FUSE OR EQUIVALENT.
2. THE METERING PROVIDER MAY USE AN INTEGRATED METER IN PLACE OF THE SEPARATE CONTROLLED LOAD METER AND AF RECEIVER.

TYPICAL LAYOUT OF A CURRENT TRANSFORMER OPERATED METER PANEL INCORPORATING A DIRECT CONNECTED METER FOR A SEPARATE CONTROLLED SUPPLY.

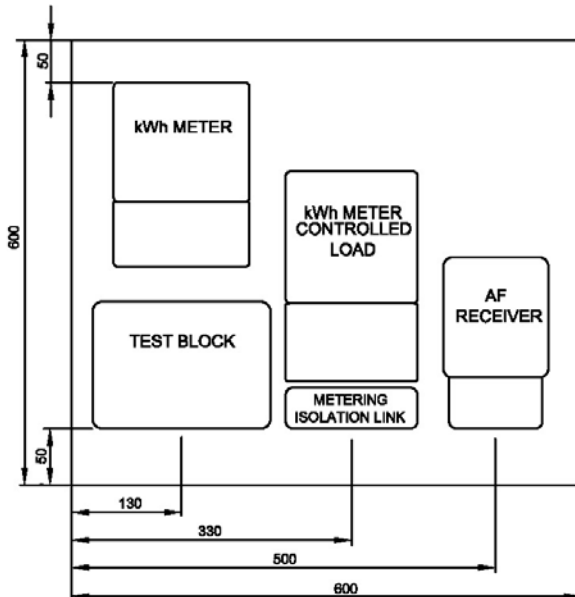

TYPICAL LAYOUT FOR SINGLE NMI CT. METERING

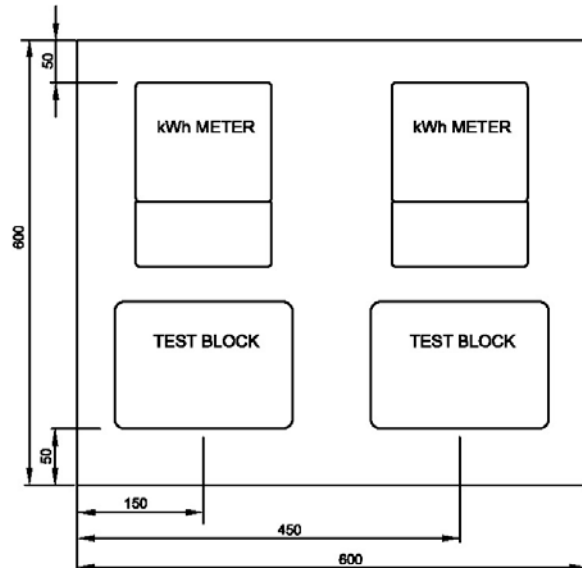

NOTE:
REFER TO CLAUSE 6.19.2.

Revision: A	TYPICAL PANEL LAYOUT & SINGLE LINE DIAGRAM CT. OPERATED METER PANEL	QECMM - 6.11
------------------------------	--	---------------------

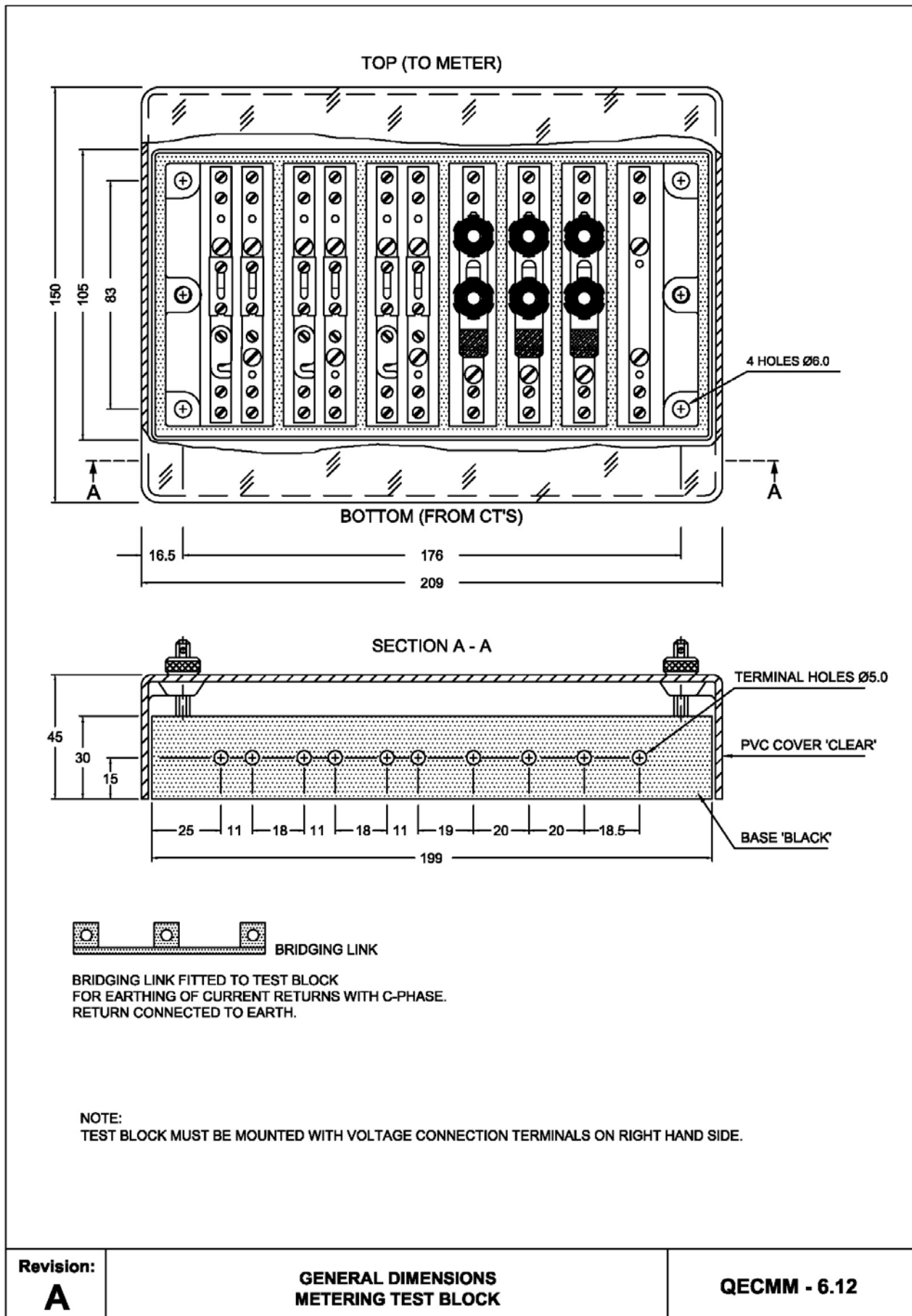

7. CONTROLLED SUPPLIES - METHOD OF CONTROL

7.1. General

For *controlled supplies*, the *distributor* will supply a *network device*.

Two and three switch *network devices* will be utilised for the following situations:

- (a) For single installations where a combination of water heating and other *controlled loads* are connected. (Refer to Drawings QECMM 7.1, 7.3, 7.5, 7.6 and 7.7).
- (b) For multiple installations, such as flats and home units. (Refer to Drawing QECMM 7.4)

The *electrical contractor* shall install all *network device* wiring.

The *electrical contractor* shall install all meter wiring unless an agreement has been negotiated with the *metering provider*.

Equipment connected to a *controlled supply* is to be permanently connected however specific equipment may be connected via a socket outlet at the *distributor's* discretion (refer to Frequently Asked Questions document in Technical Documents Section of *distributor's* website).

Where a socket outlet is provided for this purpose, it shall be dedicated to the *controlled supply* equipment (spare *controlled supply* outlets are not permitted).

A permanent indelible label shall be fixed on or adjacent to the socket outlet stating the following:

Controlled Supply Only

7.2. Network Devices

7.2.1

Where equipment other than water heating, is to be connected to a *controlled supply*, this equipment is to be connected via a dedicated circuit and connected to a dedicated switch in a multi-switch *network device*.

Note: On existing installations where submains are installed from the main switchboard/metering point to a distribution switchboard other equipment can be connected to the *controlled supply*, however, it will be switched at the same time as the hot water supply. This shall only be permitted provided the main switchboard/metering point and distribution switchboard are not located within close proximity (within 20 meters) or back to back with each other.

7.2.2

Single phase installations with *controlled supplies* shall be connected in accordance with Drawings QECMM 7.1 - 7.3

7.2.3 Multiple installations where multi-switch *network devices* are utilised must be provided with a *network device* switch per *customer* in accordance with Drawing QECMM 7.4. Switching of individual *customer's* hot water by the use of contactors is not permitted.

Notes:

1. Connections to multi-switch *network devices* shall be clearly labelled to identify the switch applicable to each *customer*.
2. A separate metering isolation link is to be used for supply to the *network device(s)*. Where more than one switch per *customer* is required then an individual *network device* per *customer* shall be used as per Clause 7.2.2.

7.2.4 Poly phase installations with direct connected meters shall be connected in accordance with Drawings QECMM 7.5 – 7.8.

Note: Three phase loads (e.g. motors) shall be controlled via a *network device* switching a contactor. (Refer Drawing QECMM 7.8).

7.3. Contactor for Control of Non-Continuous Load

Where the single phase load to be controlled exceeds 30A resistive (e.g. electric water heaters), 20A inductive (e.g. motors) or a combination of resistive and inductive load (e.g. air conditioners), a contactor is required. Where a contactor is required it shall be supplied by the *customer*, be of a type acceptable to the *distributor* and shall be installed in an accessible position within the Main Switchboard, in a sealable fit for purpose enclosure (if required). (Refer to Drawings QECMM 7.2, 7.6, 7.8 and 7.9).

In the Energex distribution area an additional switch of a multi switch *network device* may be used in place of a contactor in domestic installations provided the load on each switch complies with that given above. Paralleling of switches is not permitted.

Contactors with no external moving parts are suitable for use without further protection and do not require provision for sealing.

Three phase installations requiring a contactor shall have the *network device* connected in accordance with Drawing QECMM 7.8 for *direct connected meters* and Drawing QECMM 7.9 for *current transformer metering*.

The contactor shall not be used for automatic load control (e.g. it shall not have a humidistat, a flow switch, a thermostat, a pressure switch or the like connected in its control circuit).

7.4. Size of Network Device Wiring

The wiring from a *controlled supply* meter to a *network device* (or controlled load main switch) and all meter neutral wiring shall be PVC insulated stranded copper cable of no more than 7 strands, a minimum of 4mm² and shall not exceed 6mm².

Aluminium cables are not permitted for connection directly into *network device* terminals.

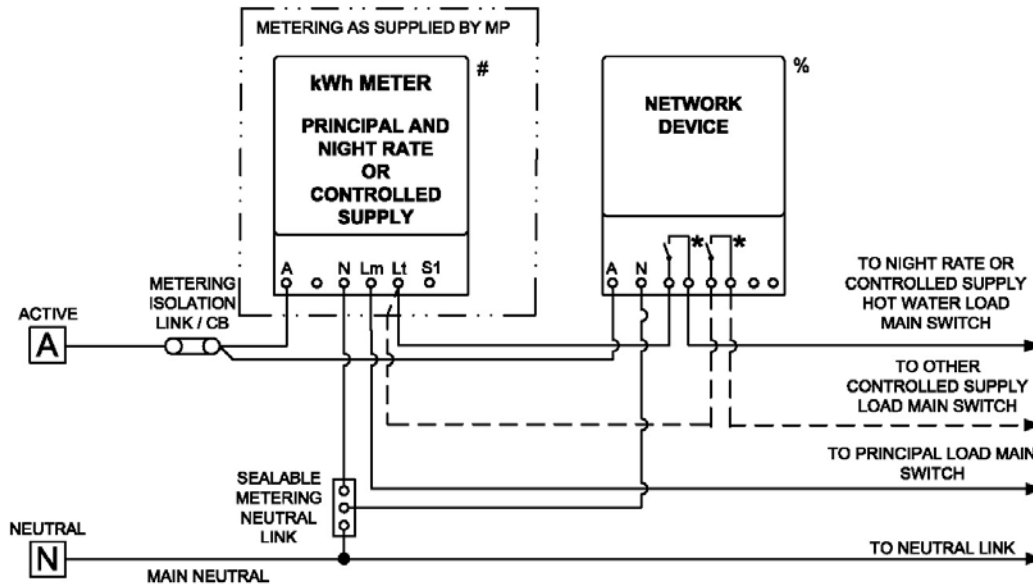

ITEMS SUPPLIED BY METERING PROVIDER.
 % ITEMS SUPPLIED BY DISTRIBUTOR.
 * SWITCH POSITION AND NUMBER OF SWITCHES DETERMINED BY SUPPLY AND LOAD TYPE.

- NOTES:
1. ELEMENT 1 FOR PRINCIPAL SUPPLY ONLY, ELEMENT 2 FOR EITHER NIGHT RATE OR CONTROLLED SUPPLY.
 2. CONTROLLED CIRCUIT ASSOCIATED WITH SECONDARY SUPPLY CONNECTED TO UNSWITCHED TERMINAL OF TWO ELEMENT METER.
 3. SECONDARY SUPPLY SWITCHING IS DONE BY THE NETWORK DEVICE.
 4. METERING ARRANGEMENT INDICATIVE FOR POC AREAS.

Revision: A	WIRING DIAGRAM - DIRECT CONNECTED METERING SINGLE PHASE PRINCIPAL SUPPLY PLUS NIGHT RATE OR CONTROLLED SUPPLY	QECMM - 7.1
------------------------------	--	--------------------

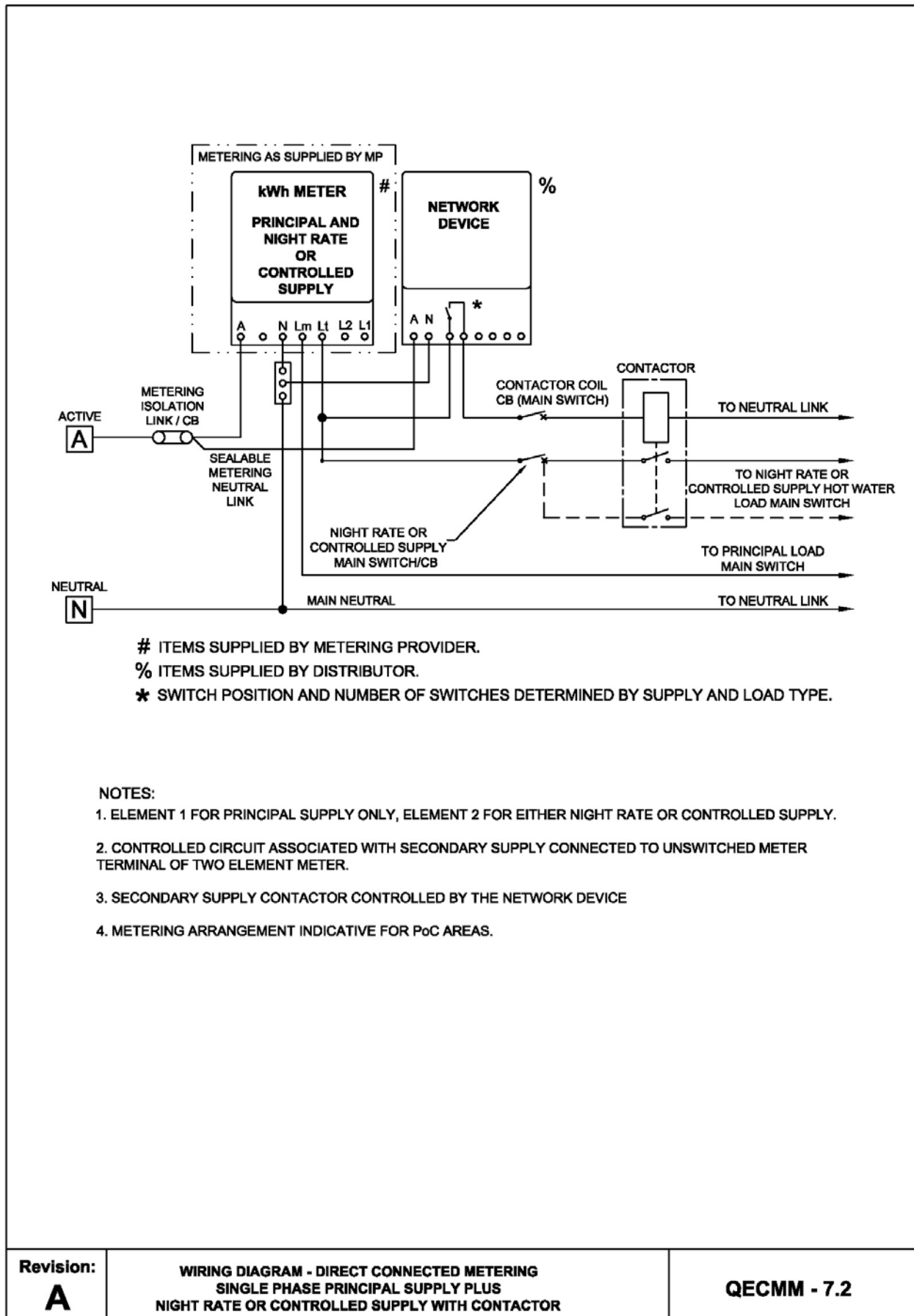

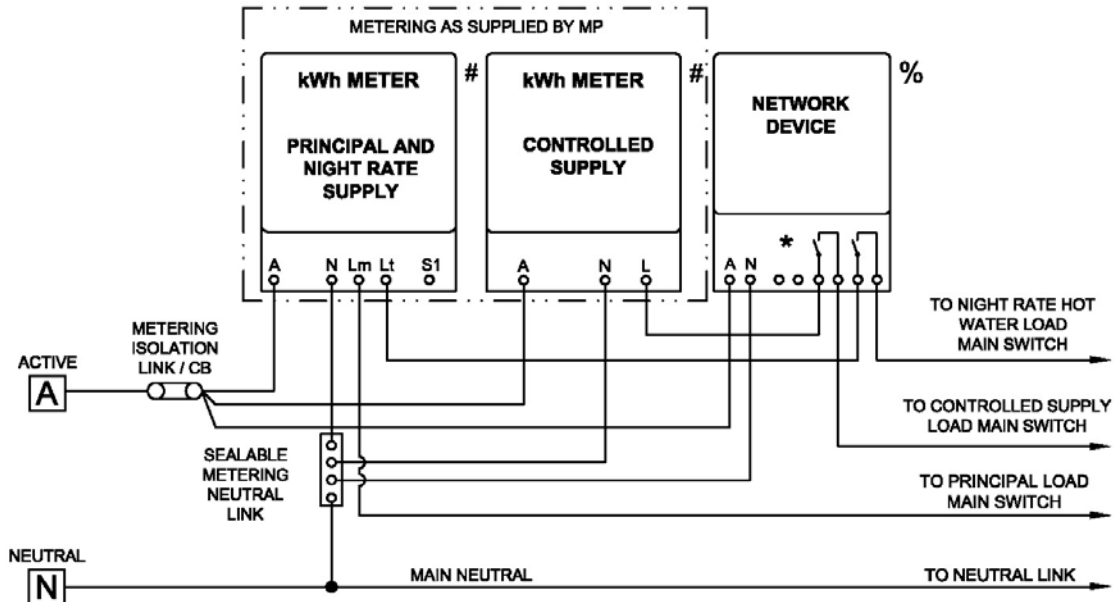

ITEMS SUPPLIED BY METERING PROVIDER.
 % ITEMS SUPPLIED BY DISTRIBUTOR.
 * SWITCH POSITION AND NUMBER OF SWITCHES DETERMINED BY SUPPLY AND LOAD TYPE.

NOTES:

1. ELEMENT 1 FOR PRINCIPAL SUPPLY ONLY, ELEMENT 2 FOR EITHER NIGHT RATE OR CONTROLLED SUPPLY.
2. CONTROLLED CIRCUIT ASSOCIATED WITH NIGHT RATE SUPPLY CONNECTED TO UNSWITCHED TERMINAL OF TWO ELEMENT METER.
3. SECONDARY SUPPLY SWITCHING IS DONE BY THE NETWORK DEVICE.
4. METERING ARRANGEMENT INDICATIVE FOR PoC AREAS.

Revision:

A

**WIRING DIAGRAM - DIRECT CONNECTED METERING
 SINGLE PHASE PRINCIPAL SUPPLY PLUS
 NIGHT RATE AND CONTROLLED SUPPLIES**

QECMM - 7.3

QLD Electricity Connection and Metering Manual



Part of the Energy Queensland Group

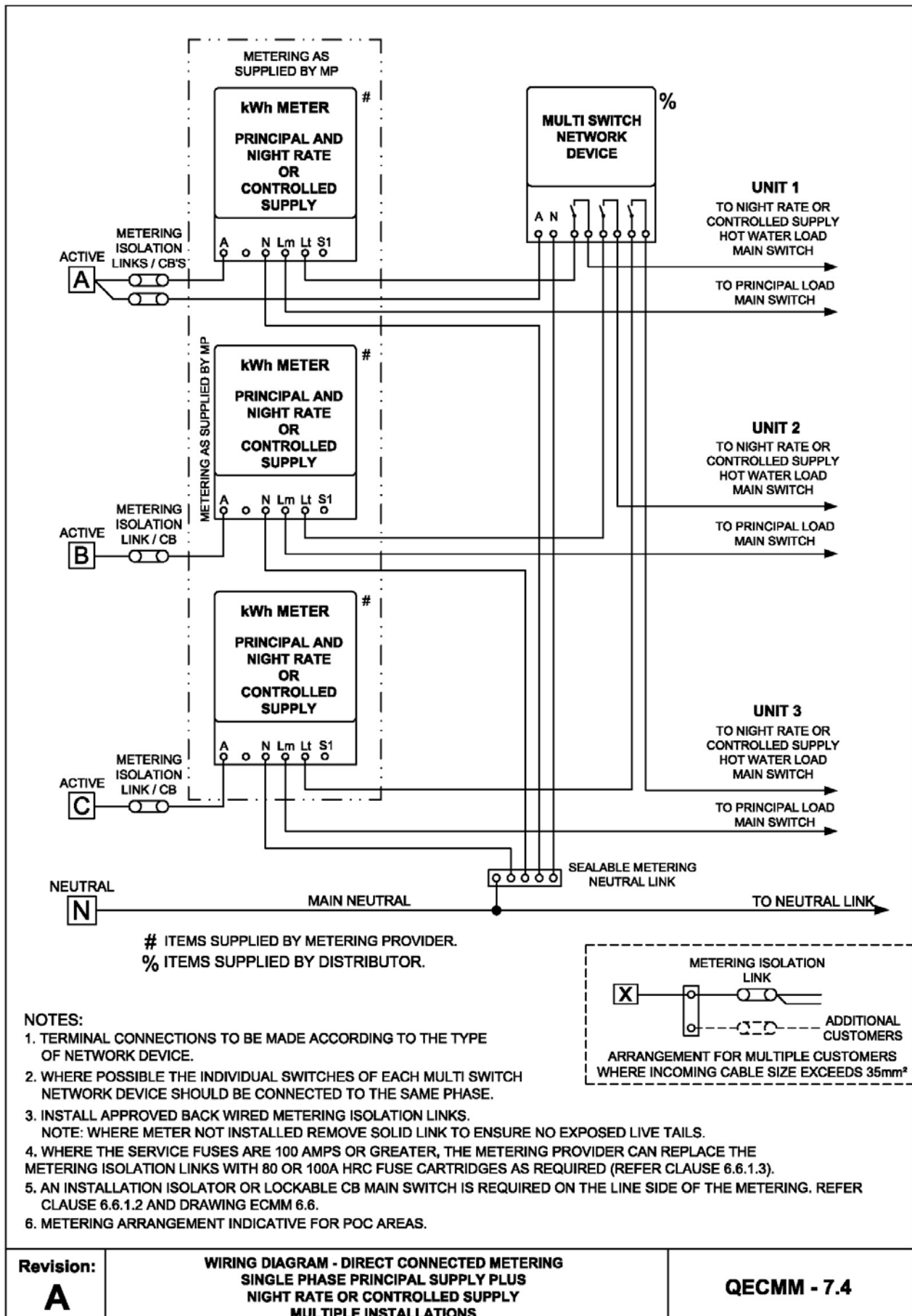

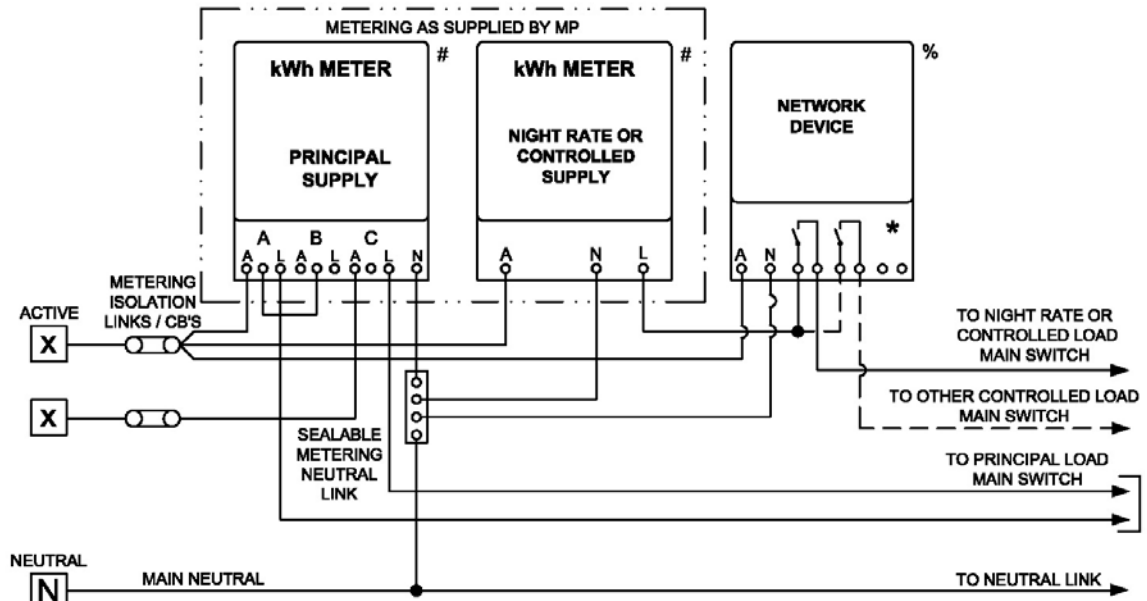

- # ITEMS SUPPLIED BY METERING PROVIDER.
- % ITEMS SUPPLIED BY DISTRIBUTOR.
- * SWITCH POSITION AND NUMBER OF SWITCHES DETERMINED BY SUPPLY AND LOAD TYPE.

NOTES:

1. METERING ARRANGEMENT INDICATIVE FOR PoC AREAS.

Revision:

A

**WIRING DIAGRAM - DIRECT CONNECTED METERING
TWO PHASE PRINCIPAL SUPPLY PLUS
SINGLE PHASE NIGHT RATE OR CONTROLLED SUPPLY**

QECMM - 7.5

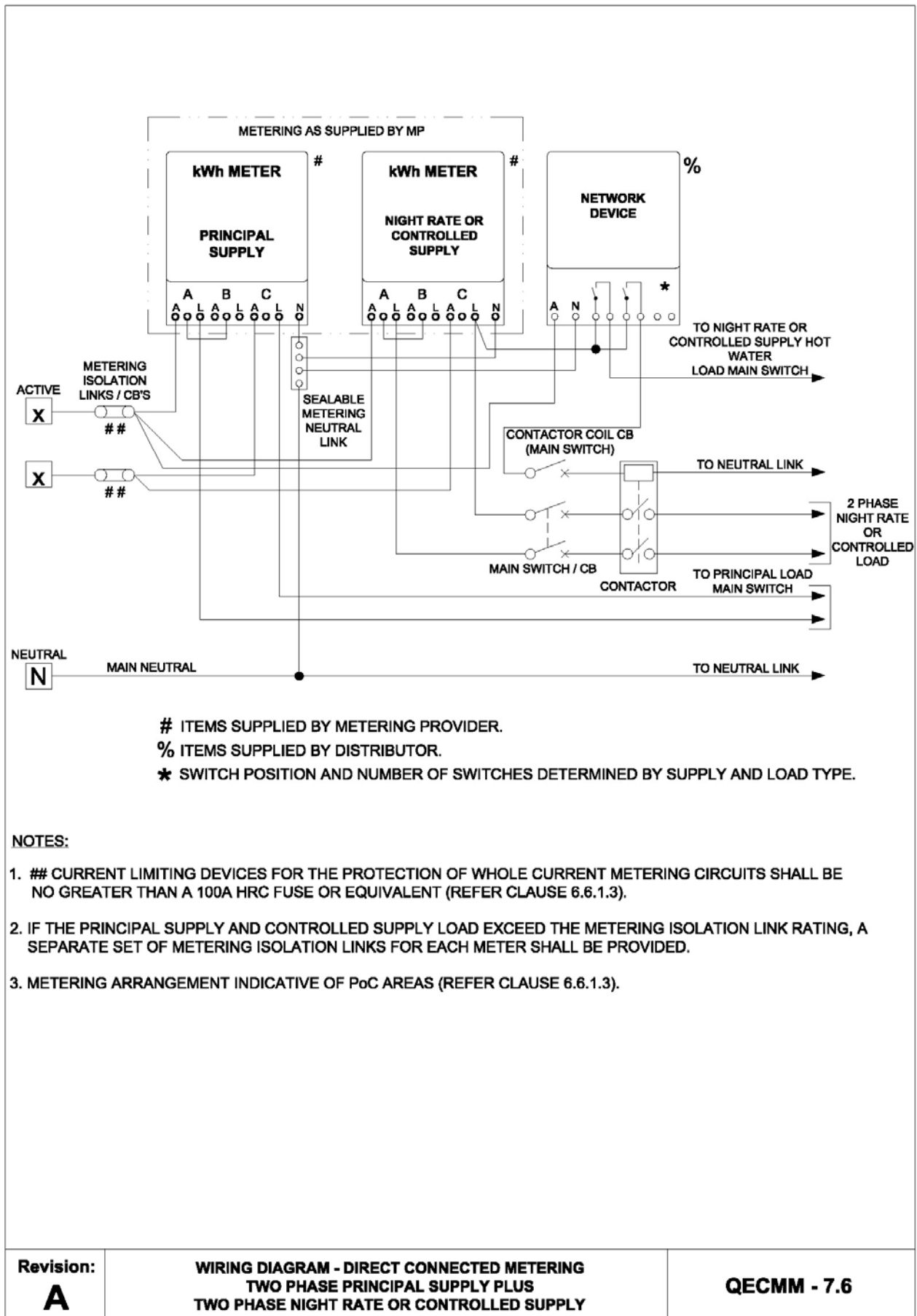

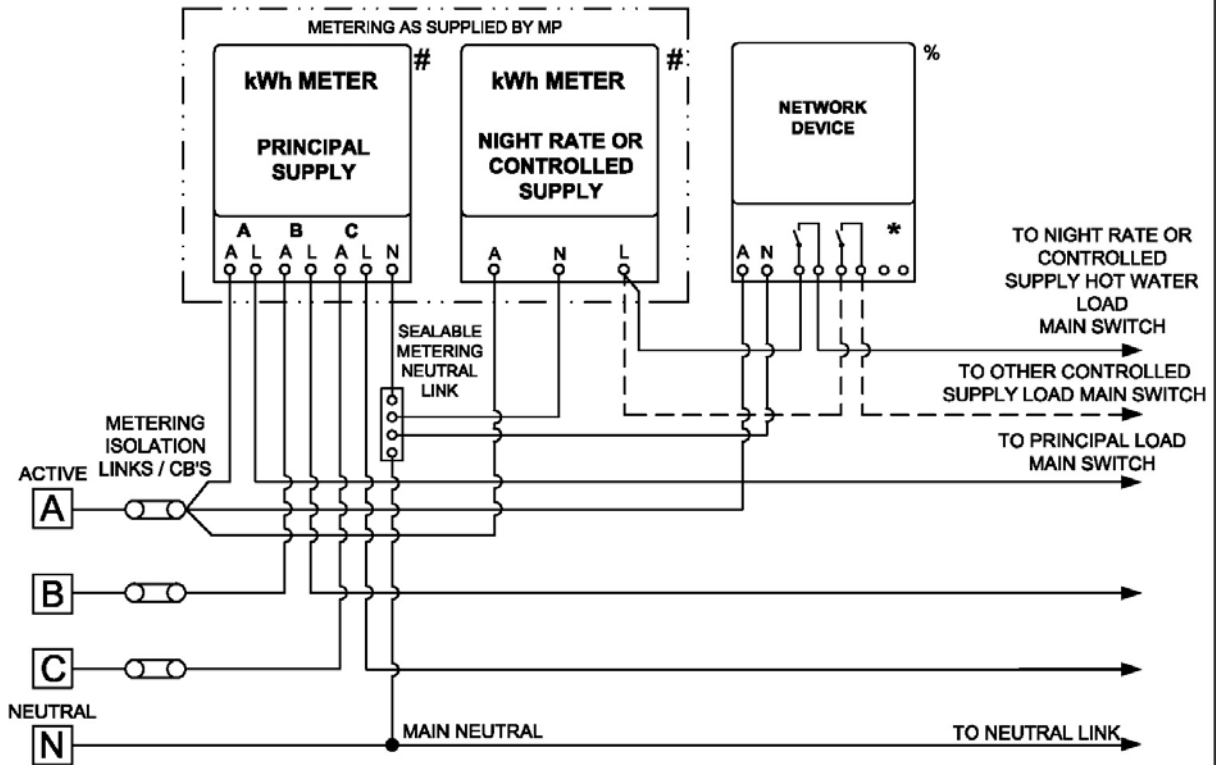

- # ITEMS SUPPLIED BY METERING PROVIDER.
- % ITEMS SUPPLIED BY DISTRIBUTOR.
- * SWITCH POSITION AND NUMBER OF SWITCHES DETERMINED BY SUPPLY AND LOAD TYPE.

NOTES:

1. OTHER CONTROLLED SUPPLY LOAD CANNOT BE CONNECTED IN CONJUNCTION WITH NIGHT RATE LOAD ON THE ONE METER (REFER TO DRAWING QECMM 7.3).
2. METERING ARRANGEMENT INDICATIVE FOR PoC AREAS.

Revision: A	WIRING DIAGRAM - DIRECT CONNECTED METERING THREE PHASE PRINCIPAL SUPPLY PLUS SINGLE PHASE NIGHT RATE OR CONTROLLED SUPPLY	QECMM - 7.7
------------------------------	--	--------------------

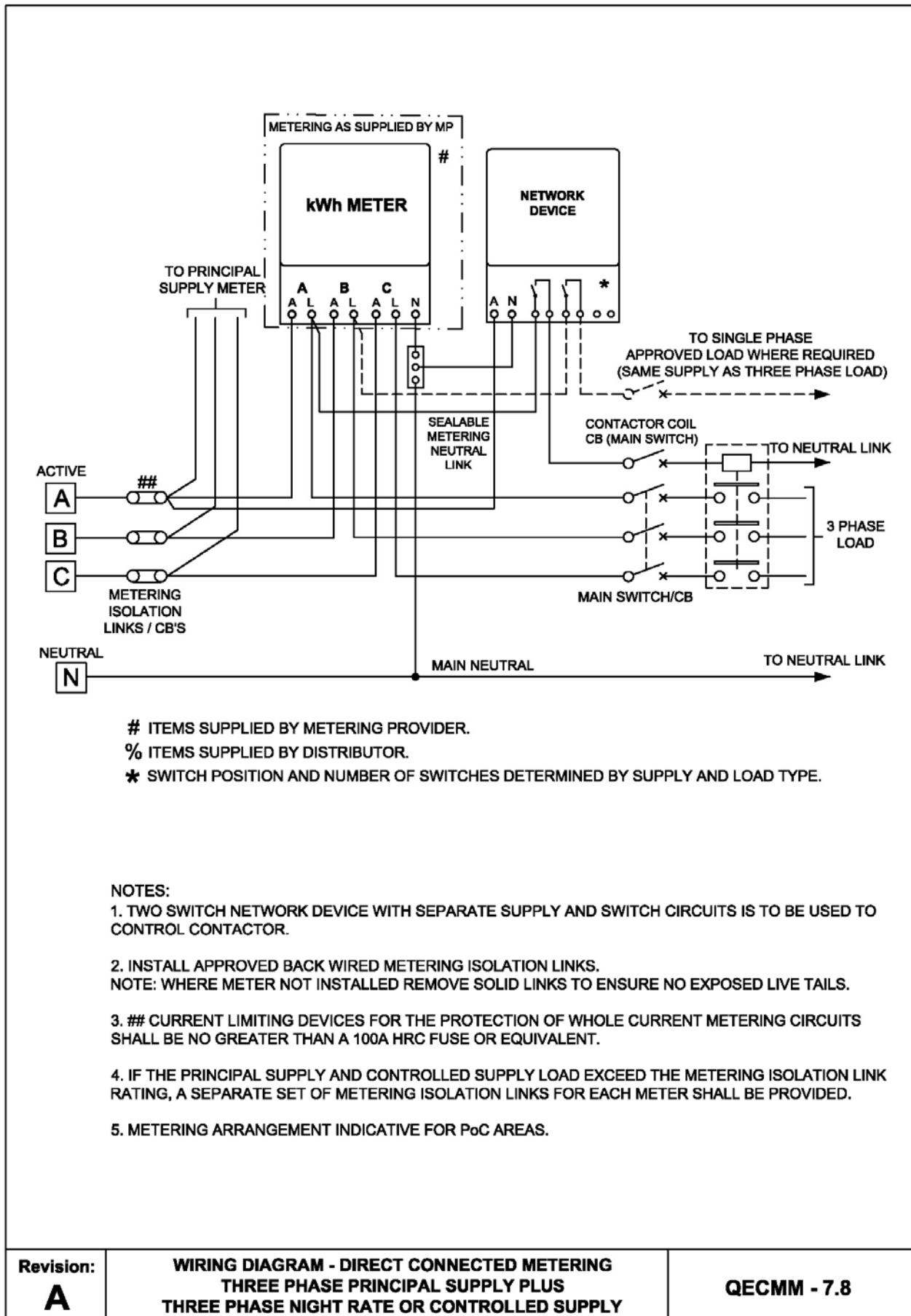

QLD Electricity Connection and Metering Manual



Part of the Energy Queensland Group

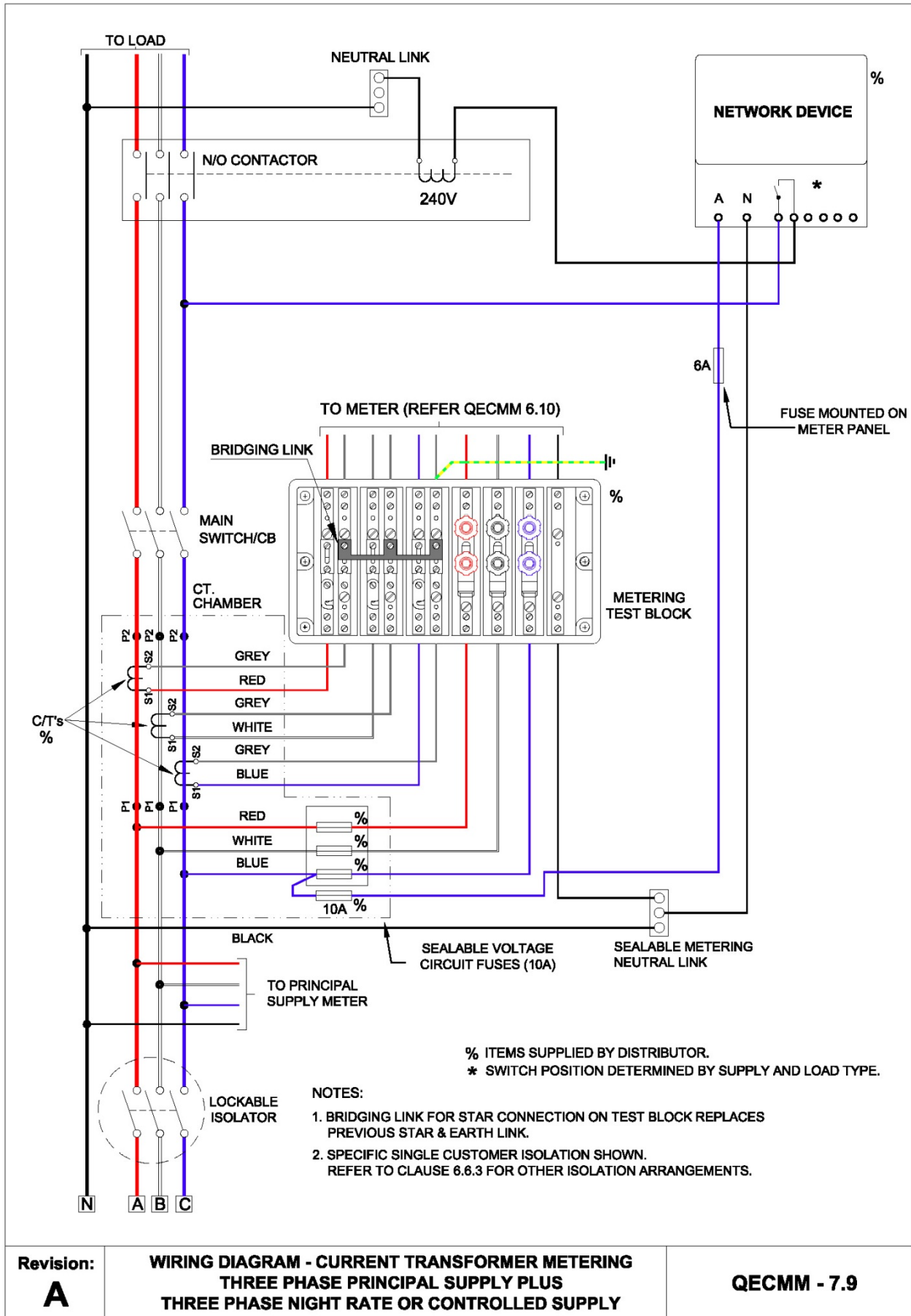

QLD Electricity Connection and Metering Manual



Part of the Energy Queensland Group

THIS PAGE HAS BEEN DELIBERATELY LEFT BLANK

8. ARRANGEMENTS FOR MICRO EMBEDDED GENERATING UNITS CONNECTED TO THE DISTRIBUTION NETWORK

8.1. Explanation of Metering Schemes Available

Two metering schemes are available for the grid-connected *Micro Embedded Generating Units (MEGU)*, known as the “*Net Energy*” and the “*Gross Energy*” schemes (also known as Embedded and Dedicated *MEGU* systems respectively). All *MEGU* installations must be compliant with AS4777. Any *EVSE* installation capable of export to the grid (i.e. vehicle to grid) will be treated as an *MEGU*. *MEGU* installations shall be compliant with EESTNW1170/EXSTD01143.

The Queensland Government Solar Bonus Scheme requires the installation of a *Net Energy* metering solution.

The *Net Energy* metering scheme has a single import/export meter installed in the place of the existing general supply energy consumption meter(s).

The *Gross Energy* metering scheme may require an additional import/ export meter installed on the meter panel to record the *MEGU* supply energy generation only.

Controlled load metering arrangements are unaffected by the installation of an *MEGU*.

8.2. Agreements

All *MEGU customers* must have an *MEGU Network Connection Agreement* in place with the *distributor* before the *MEGU* system can be connected to the *distributor's* supply network. This includes systems that are configured as ‘nil-export’ back to the distribution network.

From 1 July 2014, new arrangements commenced for the Queensland Government Solar Bonus Scheme (SBS). Within Energex’s network area, new *MEGU* connections are not eligible for the SBS. For existing connections on the 44 cents per kilowatt hour Feed-in Tariff (FiT) under the SBS, a relevant change of electricity account holder or increase in inverter capacity will render the premises ineligible for the SBS.

Within Ergon Energy’s network area, the mandated scheme is still available. For existing connections under the 44 cents per kilowatt hour SBS, a relevant change of electricity account holder or increase in inverter capacity will render the premises ineligible for the 44 cents per kilowatt hour FiT. The premises may or may not still be eligible for the mandated scheme. *Customers* should consult the Queensland Government Web site www.cleanenergy.qld.gov.au to determine their eligibility for this scheme.

The *customer* or their agent shall nominate the metering scheme on the application form for network connection of an *MEGU*, and the *electrical contractor* shall nominate the metering scheme on their *Electrical Work Request* sent to the *distributor*.

Customers wishing to be compensated for any electricity exported by the *MEGU* to the *distributor's* supply network other than through the Queensland Government Solar Bonus Scheme must also have a Power Purchase Agreement in place with their *retailer*.

8.3. Approval of Equipment

Typical *direct connected metering* arrangements have been developed in line with *MEGU* requirements and *retailer* offered supply types however it is up to the *metering provider* to install suitable metering arrangement to meet site requirements

For the “*Net Energy Scheme*” Drawings QECMM 7.1 to 7.8 cover typical single and polyphase supply/service connections for single and polyphase *Micro Embedded Generating Units*, compliant to AS 4777.1.

QLD Electricity Connection and Metering Manual



Part of the Energy Queensland Group

For the “*Gross Energy Scheme*” Drawings QECMM 8.1 and 8.2 cover typical single and three phase supply/service connections for single and polyphase *Micro Embedded Generating Units* compliant to AS 4777.1.

Notes:

1. Exceptions to the above standards may be approved upon receipt of a written application in exceptional circumstances. Applications shall be made in writing to the *distributor*. Standard charges will apply for such arrangements.
2. It must be noted that the “*Gross Scheme*” may require an additional meter, and the end user must be made aware that provision of this space is required at the current metering location.
3. In a “*Net Scheme*”, if the principal metering has more than one phase, then the *distributor* requires that a polyphase meter must be used.

8.4. Connection Requirements for Micro Embedded Generating Units

Connection requirements associated with *MEGU* connected to the distribution network shall be in accordance with:

Total Inverter Rating (kVA)	Energex	Ergon Energy
Up to and including 30kVA	Standard 1143	STNW1170
Greater than 30 kVA	Standard 233	STNW1165

8.5. Labelling Requirements to AS 4777

The installation shall be compliant with the labelling requirements of AS 4777 for Grid Connected *Micro Embedded Generating Units*.

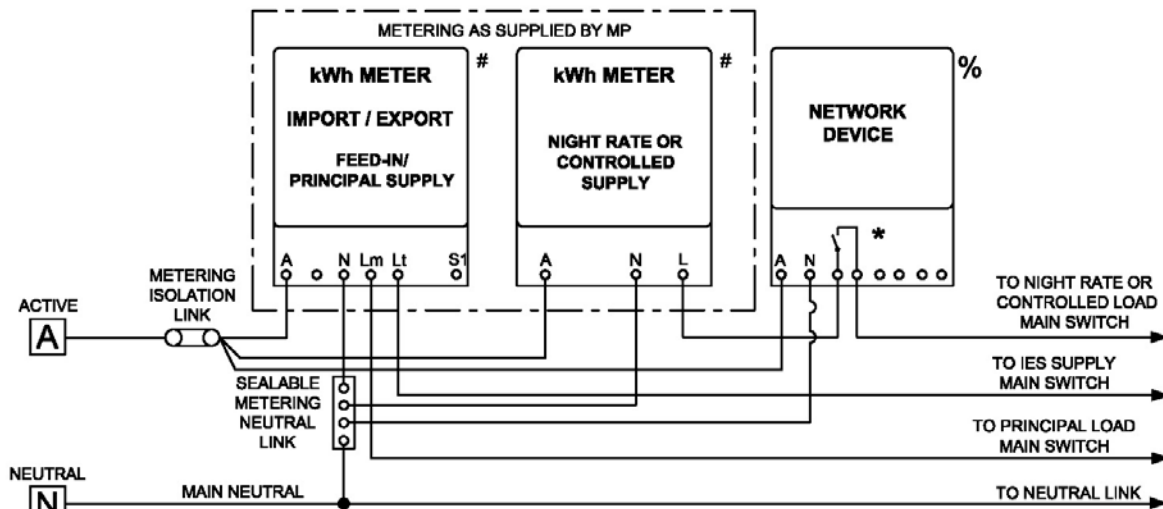

- # ITEMS SUPPLIED BY METERING PROVIDER.
- % ITEMS SUPPLIED BY DISTRIBUTOR.
- * SWITCH POSITION AND NUMBER OF SWITCHES DETERMINED BY SUPPLY AND LOAD TYPE.

NOTES:

1. BI-DIRECTIONAL SINGLE PHASE ELECTRONIC METER REQUIRED FOR IMPORT / EXPORT ENERGY REGISTRATION.
2. INVERTER ENERGY SYSTEM (IES) COMPLIANT TO AS4777 CONNECTED WITHIN THE INSTALLATION ON THE CUSTOMERS SIDE OF THE IES SUPPLY MAIN SWITCH.
3. TWO ELEMENT METER TERMINAL DESCRIPTION.

1	A - ACTIVE IN
3	N - NEUTRAL IN
4	Lm - ELEMENT 1 (MAIN - PRIMARY LOAD)
5	Lt - ELEMENT 2 (UNSWITCHED - IES SUPPLY)
6	S1 - NOT USED

4. METERING ARRANGEMENT INDICATIVE FOR PoC AREAS.

Revision:

A

**WIRING DIAGRAM - DIRECT CONNECTED METERING
GROSS METERING SCHEME
SINGLE PHASE PRINCIPAL SUPPLY PLUS
NIGHT RATE OR CONTROLLED SUPPLY**

QECMM - 8.1

QLD Electricity Connection and Metering Manual



Part of the Energy Queensland Group

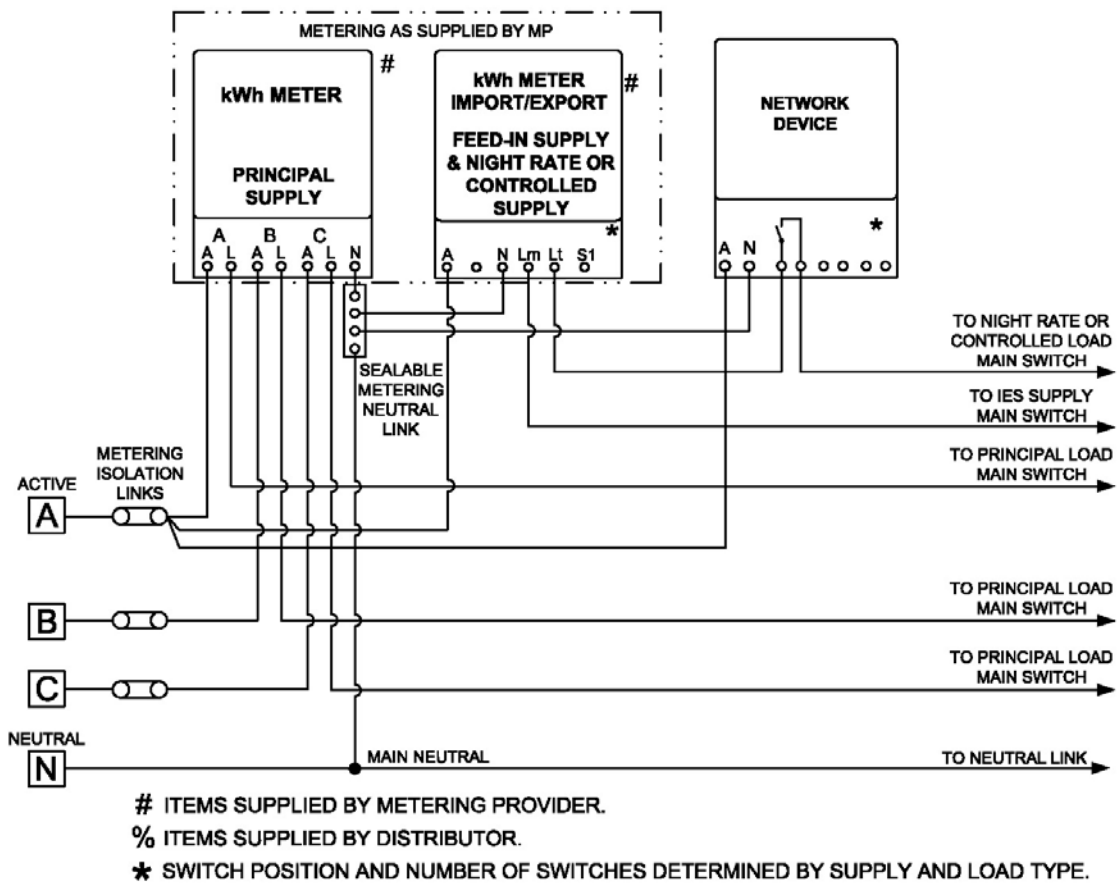

NOTES:

1. INVERTER ENERGY SYSTEM (IES), COMPLIANT TO AS4777, CONNECTED WITHIN THE INSTALLATION ON THE CUSTOMERS SIDE OF THE IES SUPPLY MAIN SWITCH.
2. METERING ARRANGEMENT INDICATIVE FOR PoC AREAS.

<p>Revision: A</p>	<p>WIRING DIAGRAM - DIRECT CONNECTED METERING GROSS METERING SCHEME THREE PHASE PRINCIPAL SUPPLY PLUS SINGLE PHASE NIGHT RATE OR CONTROLLED SUPPLY</p>	<p>QECMM - 8.2</p>
--------------------------------------	---	---------------------------

9. HIGH VOLTAGE METERING

9.1. General Requirements

The *customer* is required to supply, install and maintain all electrical equipment supplied by the *customer*. All high voltage equipment must be compatible with the *distributor's* supply. Relays, current transformers and other protective equipment must have characteristics compatible with the *distributor's* existing protective system.

The design, construction and installation of all high voltage equipment shall comply with the appropriate Australian Standards (e.g. AS/NZS 3000 (Wiring Rules) and AS 2067) or other equivalent Standards (e.g. IEC Standards). Plans, drawings and particulars describing the proposed installation and its operating conditions shall be provided.

The *distributor* will advise the *customer* of the prospective fault level and the normal fluctuations of supply voltage for which provisions should be made.

9.2. Testing Requirements

The *customer* shall meet the cost of any high voltage testing as required by AS 2067 and auditing in accordance with the Electrical Safety Act 2002.

The metering coordinator shall ensure that high voltage revenue metering instrument transformers are tested and maintained in accordance with the National Electricity Rules.

9.3. Operation of High Voltage Equipment

The *customer* is responsible for ensuring that the high voltage installation is operated in accordance with the requirements of the Electrical Safety Act 2002, the Electrical Safety Regulation 2013 and the Code of Practice for Electrical Work.

The *customer* has an obligation to ensure all persons who are involved in the high voltage isolation and access procedures have been trained and assessed as competent to perform the roles for which they are responsible.

Testing, earthing and safety equipment suitable for operation of the high voltage equipment shall be readily available on site.

For high voltage installations consisting of more than one item of switchgear, an operating diagram in the form of a single line schematic of the complete installation is to be permanently displayed adjacent to the main switch or switches.

Where items of switchgear are remote from the main switchboard, it is recommended that the operating diagram also be permanently displayed at these locations.

9.4. Maintenance and Repairs of High Voltage Equipment

A *customer* who takes supply at high voltage shall ensure that the high voltage installation is maintained so that any malfunction will not create a hazard or cause interference to the *distributor's* supply.

All costs associated with the maintenance or repairs of the *customer's* high voltage installation shall be met by the *customer*.

Note: The *customer* must be prepared for power interruptions during high voltage testing procedures, maintenance or repairs.

9.5. Conversion from Low Voltage Supply to High Voltage Supply

A *customer* planning to convert from supply at low voltage to supply at high voltage shall negotiate with the *distributor* before commencement of work.

Options to be considered may include the following:

- (a) Replacement of the *distributor's* substation and other assets or purchase of this equipment from the *distributor*; and
- (b) Any costs associated with converting the installation for compliance with AS/NZS 3000 (Wiring Rules) and AS 2067.

9.6. Metering Requirements

The *customer* or *customer's* representative (electrical contractor or consultant) must contact the *distributor* prior to commencing any project that may require high voltage metering. High voltage metering is complex and the following may need to be considered:

- (a) Specialised metering design (voltage change-over schemes etc.).
- (b) Compliance with the *National Electricity Rules*.
- (c) Equipment with long lead times (e.g. 6 to 12 months) may be required.
- (d) Full or partial check metering requirements for large loads.
- (e) Generator connections and import/export load flows.
- (f) Test certificates for metering instrument transformers from an accredited laboratory.

The relevant metering requirements in previous chapters also apply to high voltage installations. Where there are differences between the information in Section 9 and the remainder of the *QECMM*, the requirements of Section 9 prevail in relation to *high voltage metering*. The additional details contained in Section 9 are specific to *high voltage metering* installations. The *distributor* or *metering provider* can be contacted for additional information.

9.7. Establishing a Network Connection and *NMI*

For high voltage connections the process of metering the site, data collection and settlement of energy requires the following steps:

1. The *customer* is required to engage an electricity *retailer* licensed to operate in Queensland.
2. The *retailer* is required to appoint a *metering coordinator*.
3. The *metering coordinator* is required to appoint the *metering data provider* and the *provider*.
4. The *retailer* is required to submit a *SOR* to the *distributor* to make the network connection.

The above process will establish a *NMI* per *connection point* in line with the *distributor's* policies and the *AEMO* "National Metering Identifier Procedure" (refer to Flowchart 7 – Initial Connection – High Voltage Installation in Responsibilities Section).

9.8. Offer of Supply Letter and/or Network Connection Agreement

The *distributor* will negotiate a connection agreement detailing the conditions for the high voltage supply. This correspondence will include network requirements and the responsibility for providing the *high voltage metering*.

9.9. Connection point

Refer to Clause 5.2.2 for *connection point* arrangements.

The revenue metering point shall be located as close as practicable to the *connection point*.

9.10. Revenue Metering

The arrangement for the high voltage revenue metering installation will be determined during the connection enquiry and application process:

- (a) A Type 1-3 metering installation; as required for HV connections is an unregulated distribution service in Queensland and the *customer* is responsible for supplying, installing, maintaining and testing the metering installation including the instrument transformers.
- (b) The metering installation contains the metering current transformers and the metering voltage transformers (revenue metering instrument transformers). Wherever practicable this equipment shall be located within the *customer's* installation and be accessible to the *metering provider*. The metering installation shall comply with the requirements outlined in the AEMO Metrology Procedure Part A and the National Electricity Rules Chapter 7 and be approved by the *metering coordinator*.
- (c) The *customer* shall provide revenue metering instrument transformers, associated equipment and plant. The equipment must be ready for the nominated *metering provider* to connect metering and communication equipment.
- (d) Revenue metering instrument transformers will remain the *customer's* property, and the *customer* will be responsible for maintaining, servicing and if failure occurs, replacing the metering instrument transformers in accordance with the requirements of the National Electricity Rules.

Note: Any fault or defect is required to be rectified within 2 business days or the *metering coordinator* must obtain an exemption from AEMO.

- (e) The revenue metering instrument transformers are to be specified, installed, tested and maintained in accordance with the requirements of the National Electricity Rules, relevant Australian Standards (AS/NZS 3000 (Wiring Rules), AS 2067, AS 1243, AS 60044 series) and the QECMM.
- (f) Instrument Transformer test certificates in accordance with the requirements of the National Electricity Rules Schedules 7.2 and 7.3 shall be provided to the *metering provider* prior to installation of the equipment.
 - i) Where revenue metering instrument transformers are tested in Australia, endorsed reports from a laboratory accredited by NATA are required; or
 - ii) Where revenue metering instrument transformers are tested overseas, endorsed reports from a laboratory accredited by an organisation recognised by ILAC (International Laboratory Accreditation Cooperation) are required.
- (g) Metering installation designs that are approved by a *metering provider* or *metering coordinator* shall also be provided to the *distributor* prior to connection. The *customer* shall supply a single line diagram, HV switchboard layout, and a schematic diagram showing the wiring details from the instrument transformers (current and voltage transformers) to the metering panel.
- (h) The *customer* is required to supply, install and test the secondary wiring and meter enclosure/panel and terminate the secondary wiring at the meter panel and the metering instrument transformers.
- (i) The *customer* is responsible for ensuring that all requirements and steps in the metering installation process are coordinated in an efficient and timely

manner to allow supply to be connected when required.

- (j) The *customer* shall provide readily accessible high voltage test points on either side of the metering instrument transformers, in the specification/design of their switchgear. This will enable the *metering provider* to conduct the periodic high voltage metering instrument transformer accuracy tests (e.g. primary injection tests), required by the National Electricity Rules, with minimal power outages and disruption to the *customer* and their equipment.
- (k) For metering installations greater than 1000 GWh pa per connection point, the current transformer core and secondary wiring associated with the meter(s) shall not be used for any other purpose unless otherwise agreed by AEMO.
- (l) For metering installations less than 1000 GWh pa per connection point the current transformer core and secondary wiring associated with the meter(s) may be used for other purposes (e.g. local metering or protection) provided the *metering coordinator* demonstrates to the satisfaction of AEMO that the accuracy of the metering installation is not compromised and suitable procedures/measures are in place to protect the security of the metering installation.
- (m) The metering voltage instrument transformers may be used to supply *customers* metering at the discretion and approval of the *metering provider* on a case by case basis. The secondary voltage supply from the voltage transformers will be separately fused with fuses located in an accessible position as near as practicable to the voltage transformer secondary connection. The revenue metering instrument transformers' secondary wiring is to be earthed at one point only in accordance with the *metering provider's* requirements.
- (n) The minimum spacing between the meter wiring and other current carrying conductors shall comply with TABLE 6.4.
- (o) Adequate and safe access must be provided for the installation, routine and corrective maintenance of revenue metering equipment in accordance with AEMO requirements.

9.11. Meter Enclosure

The following requirements apply to *high voltage metering* enclosures:

- (a) Unless otherwise detailed in the supply agreement the *customer* must supply a pre-wired meter panel and enclosure to the requirements of the *metering provider*. Wiring diagrams can be obtained from the *metering provider*.
- (b) Any metering enclosure mounted externally must have an appropriate IP rating and be positioned so that adequate mechanical protection is provided.
- (c) A hinged panel with minimum dimensions of 600mm x 600mm is required for the mounting of meters and metering test block on the same vertical surface.
- (d) A metering enclosure installed on a pole in association with a *distributor* owned metering unit, will be supplied and maintained by the *distributor*.
- (e) No *customer* owned equipment is to be installed within the *metering provider's* dedicated metering enclosure.
- (f) The supply and wiring of the meter panel may be carried out by the *metering provider* as part of a negotiated agreement.

- (g) The *customer* is responsible for earthing of the metering enclosure in accordance with relevant standards and practices including consideration for earth potential rise.
- (h) The *customer* should consider providing lockable front meter doors in locations where security may be an issue.

9.12. Secondary Wiring

The following requirements apply to metering units supplied by the *metering provider* and revenue metering instrument transformers owned and installed by the *customer*.

- (a) The *customer* shall supply and install the secondary wiring between the revenue metering instrument transformers and the test block or terminal strip.
- (b) Revenue metering instrument transformer secondary wiring is to follow the most direct route and the number of terminations and links must be kept to a minimum.
- (c) Revenue metering instrument transformer secondary wiring is to be PVC insulated stranded cable of no more than 7 strands.
- (d) The secondary wiring shall be sized to ensure that the burden on the revenue metering instrument transformers is not exceeded.
- (e) All taps of multi-tap CTs to be brought out to the marshalling box or metering enclosure (in the absence of a marshalling box).
- (f) Any connection point in the revenue metering instrument transformers' secondary circuit (terminals, links, fuses etc.) that is accessible must be identified as "Revenue Metering" and must be able to be covered and sealed.

QLD Electricity Connection and Metering Manual



Part of the Energy Queensland Group

THIS PAGE HAS BEEN DELIBERATELY LEFT BLANK

APPENDIX A - SPECIFICATION FOR METALLIC ENCLOSURES FOR METERS IN DIRECT CONNECTED INSTALLATIONS

Foreword

This specification provides for metallic enclosures only. The use of other materials, such as fibreglass or plastic is subject to the approval of the *distributor*. In such cases, the general requirements of this specification may provide guidance.

A.1 Scope and General

A.1.1 Scope

This specification provides standard requirements for metallic enclosures for revenue meters and control equipment used in Direct Connected installations.

A.1.2 Definitions

A.1.2.1 *Approved* - means approved by the *metering provider*.

A.1.2.2 *Direct Connected Installation* - means an installation that is metered by Direct Connected meters.

A.1.2.3 *Meter Enclosure* - means an enclosure used for the purpose of housing revenue metering equipment.

A.1.2.4 *Meter Panel* - means a panel to be mounted in the meter enclosure and on which metering equipment is fixed.

A.1.2.5 *Metering Equipment* - means the equipment used for measuring or controlling the supply of electrical energy.

A.1.2.6 *Weatherproof* - means so constructed and installed as to exclude rain, hail and external splashing so that the safe and efficient operation of the equipment contained therein shall not be impaired. (e.g. IP23).

A.2 Design and Construction

A.2.1 Materials

The meter enclosure may be constructed from the following:

MATERIAL	MINIMUM THICKNESS (mm)
Mild Steel	Enclosure Type A 1.0 Enclosure Type B 1.2
Aluminium	To be equivalent in strength and rigidity to the above mild steel requirements
Other Materials	To be approved

A.2.2 Construction

- A.2.2.1** The enclosure should be constructed free of burrs at the opening.
- A.2.2.2** The enclosure, if of steel construction, shall be of galvanised or zincalume material and shall comply with the requirements of AS 1397 "Steel sheet and strip - hot dip zinc-coated or aluminium/zinc-coated".
- A galvanised steel meter enclosure shall have all galvanised surfaces repaired with a suitable zinc rich coating. All exterior surfaces of the enclosure should be painted with one coat of "etch primer".
- A.2.2.3** The use of aluminium shall be restricted to corrosion resistant alloys as recommended for the exposure to be encountered in service (stainless steel is an acceptable alternative).
- A.2.2.4** Rivets shall be of a material that is compatible with the case material and must not react to set up points of corrosion.
- A.2.2.5** Where additional mechanical strength is required stiffening ribs may be utilised. Such ribs must not in any way reduce the minimum internal dimensions.

A.2.3 Door

- A.2.3.1** The meter enclosure is to be fitted with a hinged door of sufficient strength to prevent buckling or warping.
- A.2.3.2** The door shall be side hinged, unless otherwise approved by the *metering provider*, and fitted with a suitable non-corroding chain or other approved means to limit the door travel to approximately 100 degrees. The door may be hinged at either the left or right side of the meter enclosure and shall be fitted with a simple self-latching device.
- A.2.3.3** Hinges provided shall be of non-corroding material and so designed or fitted with non-corroding pins as to prevent seizing.

A.2.4 Door Latch

The latching device provided shall engage automatically and hold the door firmly closed.

A.2.5 Entry of Wiring

Adequate provisions shall be made for knockouts or slots for the entry of wiring to the meter enclosure. (Refer to AS/NZS 3000 (Wiring Rules) for fire protection requirements).

Entries may be provided in the top of the enclosure but in this case the final assembly should withstand the test in Appendix A Clause 2.7.

A.2.6 Earthing

An earthing stud or terminal complying with the requirements of AS/NZS 3000 (Wiring Rules) shall be provided for the connection of an earthing conductor within the enclosure. The stud or terminal shall not obstruct equipment within the enclosure.

A.2.7 Weatherproofing

The enclosure is to comply with AS/NZS 60529 "Degrees of Protection Provided by Enclosures" to a minimum of IP23.

The enclosure shall provide adequate ventilation to minimise condensation and be capable of draining any moisture that may collect within the enclosure.

A.2.8 Meter Panel

A.2.8.1 Meter panels shall be constructed of durable, non-conducting, fire resistant material with low water absorption properties and shall not contain asbestos.

A.2.8.2 The meter panel shall be side hinged on a vertical axis so that the metering equipment always remains in the vertical plane.

A.2.8.3 Panel hinges should be of the double off-set type that allows for the panel to be swung into the fully opened position and shall be of adequate strength to support the meter panel, and associated metering equipment.

The hinges shall be constructed of a suitable non-corroding material. When the meter panel is opened at an angle of 90 degrees, the design of the enclosure and hinges should be such to withstand without undue distortion a weight of 25kg suspended vertically at a position 25mm from the outer edge of the panel.

A.2.8.4 Where the switchboard is remote from the meter enclosure, metering equipment may be installed in the switchboard section of the meter enclosure.

A.3 Dimensions

A.3.1 General

Two basic types of meter enclosures are provided for, the dimensions of which are to be suitable for recessing into brick, block or framed walls. Other meter enclosures of adequate size to house the meters with recommended clearances and suitable construction may be used. The table below is indicative of the most commonly supplied metering enclosures that comply with the QECMM.

Metal Enclosure	Minimum Thickness Mild Steel	Minimum Space Required For Metering Equipment	Clearance From Back of Meter Panel to Back of Enclosure	Clearance From Back of Meter Panel to Inside of Door
Type A	1.0mm	480mm x 460mm (high) (wide)	75mm	185mm
Type B	1.2mm	600mm x 550mm (high) (wide)		

QLD Electricity Connection and Metering Manual



Part of the Energy Queensland Group

THIS PAGE HAS BEEN DELIBERATELY LEFT BLANK.

APPENDIX B - GLOSSARY OF TERMS

Accredited Auditor	<p>A person appointed under section 129 of the <i>Electrical Safety Act 2002</i> to audit high voltage or hazardous area installations before connection to supply.</p> <p>Further information may be obtained from the Electrical Safety Office.</p>
AEMO	<p>‘Australian Energy Market Operator’ is responsible for the day to day management of wholesale and retail energy market operations and emergency management protocols; on-going market development required to incorporate new rules, infrastructure and participants; and long term market planning through demand forecasting data and scenario analysis.</p>
AF Receiver	<p>See “Network Device”</p>
Capital Contribution	<p>A contribution towards costs associated with a standard control service, such as any necessary augmentation of connection assets at the connection point, dedicated network extension or augmentation of the shared distribution network to accommodate the connection/modification. A capital contribution will only be levied where there is a difference between the cost to provide the connection service and the revenue that will be earned by the <i>distributor</i> from the connection service.</p>
Card Operated Meter	<p>A meter that contains control equipment that switches on and off in accordance with the amount of credit stored in the meter.</p>
Common Property	<p><i>Common property</i> means so much of a parcel as from time to time is not comprised in any lot. <i>Building Units and Group Titles Act 1980</i></p>
Connection Point, Point of Supply	<p>The agreed point of supply established between Network Service Provider(s) and another Registered Participant, Non-Registered <i>Customer</i> or franchise <i>customer</i>.</p>
Connection Policy	<p>The <i>distributor’s</i> connection policy provides an outline of connection services, when connection charges may be payable by <i>customers</i> and how those charges are calculated.</p>
Consumer’s Mains	<p>The conductors between the <i>connection point</i> and the main switchboard.</p>

Consumer's Terminals	<p>Note (1): AS/NZS 3000 refers to the '<i>Connection Point</i>' as the '<i>Point of Supply</i>'. Previous editions of AS/NZS 3000 referred to the '<i>Connection Point</i>' as the '<i>consumer's terminals</i>'.</p> <p>Note (2): The <i>Queensland Electricity Regulation 2006</i> uses the definition '<i>consumer's terminals</i>'.</p> <p>Note (3): The <i>National Electricity Rules</i> uses the definition '<i>connection point</i>'.</p> <p>Note (4): This is the point which differentiates the responsibilities of the Network Service Provider and the application of AS/NZS 3000.</p>
Controlled Load, Controlled Supply	Those loads that are wired separately from other appliances, are controlled by means of frequency injection receiver or time clock, and are separately metered from the remaining load at the metering point.
Current Transformer Metering	A metering arrangement where electricity flow is measured by a meter using current transformers (CTs).
Customer	A person, including a relevant body corporate, who receives, or wants to receive, a supply of electricity for a <i>premises</i> from an electricity entity or special approval holder.
Direct Connected Meter	A meter where the electricity flow is directly measured by the meter i.e. the current under measurement passes through the meter itself.
Distribution Entity, Distributor	A distribution entity is a person who holds a distribution authority that authorises its holder to supply electricity using a supply network within its distribution area. See sections 37, 38 and 39 of the <i>Queensland Electricity Act 1994</i> . (Refer to definition for Relevant Distribution Entity).
Electrical Contractor (EC)	A person licensed under the <i>Electrical Safety Act 2002</i> to conduct a business or undertaking that includes the performance of electrical work.
Electrical Work Request (EWR)	The request from the <i>customer's</i> electrical contractor to a <i>distributor</i> to perform a distribution service e.g. (i) Energex - Form 2; or (ii) Ergon Energy - Form A - <i>Request for Initial Connection, Metering Change or Service Alteration</i>
Energex	Energex Limited - ABN 40 078 849 055
Enhanced Metering	A scheme, which is not normally considered to be part of standard metering as described in this manual (e.g. has pulse inputs, outputs, or remote communications). Additions that are above and beyond the metering provided in this manual.
Ergon Energy	Ergon Energy Corporation Limited ABN 50 087 646 062
EVSE	Electric Vehicle Supply Equipment as defined in AS/IEC 62196

QLD Electricity Connection and Metering Manual



Part of the Energy Queensland Group

Excluded Customer	A <i>customer</i> who cannot choose their <i>retailer</i> . For example, <i>customers</i> connected to isolated power systems.
Gross Energy Scheme	The <i>Gross Energy Scheme</i> separately meters the full energy output of the <i>MEGU</i> . The energy consumed at the <i>premises</i> is metered normally.
High Voltage Metering	A high voltage metering arrangement where electricity flow is measured by a meter using current transformers and voltage transformers.
Isolated Power System	A supply network that does not form part of and is not connected to the national grid and may include an isolated feeder.
Large Customer	A <i>customer</i> whose annual consumption is equal to, or greater than, 100MWh, and is connected to the distributor's network.
Large Non-market Customer	A <i>large non-market customer</i> , for <i>premises</i> , is a <i>large customer</i> for the <i>premises</i> who is also a <i>non-market customer</i> for the <i>premises</i> .
MEGU	A grid connected Micro Embedded Generating Unit (also referred to as Inverter Energy System or IES) as defined in AS 4777.
Metering Coordinator	A person who has been registered by AEMO under Chapter 2 of the <i>National Electricity Rules</i> to engage in the coordination and provision of metering services at a connection point in accordance with Chapter 7 of the <i>National Electricity Rules</i> .
Metering Data Agent	An agent appointed by AEMO to undertake the collection, processing and transfer of metering data to AEMO and other registered participants.
Metering Data Provider	A person who meets the requirements listed in schedule 7.3 of the <i>National Electricity Rules</i> and has been accredited and registered by AEMO to undertake the collection, processing, storage and delivery of metering data and the management of NMI Standing Data.
Metering Provider (MP)	A person who meets the requirements listed in schedule 7.2 of the <i>National Electricity Rules</i> and has been accredited and registered by AEMO to undertake the provision, installation and maintenance of metering installations. Note: The <i>distributor</i> is the <i>metering provider</i> in <i>non-NEM</i> areas.
Micro Embedded Generating Unit	A generator that is compliant with AS4777, that is, an inverter system to be connected to the low voltage distribution network.
NATA	The National Association of Testing Authorities.
National Electricity Rules	The rules under which the National Electricity Market operates.

QLD Electricity Connection and Metering Manual



Part of the Energy Queensland Group

National Metering Identifier (NMI)	A <i>National Metering Identifier (NMI)</i> is a unique national identifier that relates to the metering installation at a <i>customer's premises</i> .
Net Energy Scheme	The <i>Net Energy Scheme</i> provides for the separate measurement of the energy supplied from the LV network to the <i>customer's</i> installation in excess of the <i>MEGU</i> generation, and the excess energy supplied to the LV network from the <i>premises</i> by the <i>MEGU</i> after the energy needs at the <i>premises</i> are met.
Network Device, AF Receiver	Apparatus or equipment that: (a) enables a <i>distributor</i> to monitor, operate or control the network for the purposes of providing network services, which may include switching devices, measurement equipment and control equipment; and (b) is located at or adjacent to a metering installation at the connection point of a <i>customer</i> .
NMI Classification	Small - annual consumption less than 100MWh Large - annual consumption equal to, or greater than 100MWh.
Point of Attachment	The point at which aerial conductors of a <i>service line</i> or aerial <i>consumer's mains</i> are terminated on a <i>customer's</i> structure.
Point of Entry	The point at which the <i>consumer's mains</i> or the underground service cable enters a structure.
Premises	<p><i>Premises</i> includes -</p> <ul style="list-style-type: none">(a) a building or other structure; and(b) a part of a building or other structure; and(c) land where a building or other structure is situated. <p><i>Premises, of a customer, means premises owned or occupied by the customer. Queensland Electricity Act 1994</i></p>
QECMM	Queensland Electricity Connection and Metering Manual (this document)
Relevant Distribution Entity, Distributor	<p>The <i>relevant distribution entity</i> for a <i>premises</i>, means the <i>distribution entity</i> to whose supply network the <i>premises</i> are, or will be, connected.</p> <p>Note: For the purposes of this document the relevant <i>distribution entity</i> will be referred to as the '<i>distributor</i>'.</p>
Relevant Retail Entity, Retailer	<p>The <i>relevant retail entity</i> for a <i>premise</i>, means the retail entity who, under a retail contract, supplies or has agreed to supply electricity to the <i>premises</i>.</p> <p>Note: For the purposes of this document the <i>relevant retail entity</i> will be referred to as the '<i>retailer</i>'.</p>
Retail Entity	A person who holds a retail authority to sell electricity and retail services (a 'retail authority' authorises its holder to provide <i>customer</i> retail services under the terms of the authority).

RPEQ	Registered Professional Engineer Queensland.
Rural/Isolated Area	<p>A <i>rural/isolated area</i> is defined as one with a density of less than 5 lots per hectare (i.e. would generally have a dedicated supply transformer).</p> <p>Note: This definition is only applicable within the <i>Ergon Energy</i> distribution area.</p>
Service Line	<p>An electric line that-</p> <ul style="list-style-type: none">(a) forms part of the works of an electricity entity; and(b) connects <i>consumer terminals</i> to -<ul style="list-style-type: none">(i) other parts of the works of the electricity entity; or(ii) the works of another electricity entity. <p>Schedule 9 of the <i>Queensland Electricity Regulation 2006</i>.</p>
Small Customer	A <i>customer</i> who consumes less than 100MWh per annum and is connected to the <i>distributor's</i> network.
SOR	Service Order Request - This is a request from a <i>Retailer</i> to a <i>Distributor</i> to perform a distribution service (e.g. New Connections, Metering Alterations and Service Upgrades). It is also referred to as a B2B request.
Suitable Mains Connection Box	A mains connection box that is deemed to be compliant with the <i>distributor's</i> technical specifications. Details are available by contacting the <i>distributor</i> via the methods listed on page 1
Two element Meter	A single phase two element device which includes both metering and load switching within one meter.
Type 1-7 Metering Installation	As defined in the National Electricity Rules
Unmetered Supply	A Type 7 metering installation classification (<i>NER</i>) where a metering installation does not require a meter to measure the flow of electricity in a power conductor and accordingly there is a requirement to determine by other means the energy data that is deemed to flow in the power conductor and managed by the relevant Distribution Entity.
Urban	A residential area with a system of street lighting.

QLD Electricity Connection and Metering Manual



Part of the Energy Queensland Group

THIS PAGE HAS BEEN DELIBERATELY LEFT BLANK.

APPENDIX C - AMENDMENT RECORD

Please note: It is not possible to cover all of the changes in the following list, nor can the changes be covered in the detail and context as they appear within the manual. As an *Electrical Contractor* it is the responsibility of you and your endorsees to be fully conversant with the content and requirements of the Queensland Electricity Connection and Metering Manual.

Date 01/12/17 Previous Version 11

Version 12 update includes all required changes for Power of Choice only for both the text and the drawings.

Additionally, clauses have been rearranged to group similar items together.

Changes are extensive and have not been included in detail in this Appendix.

QLD Electricity Connection and Metering Manual



Part of the Energy Queensland Group

THIS PAGE HAS BEEN DELIBERATELY LEFT BLANK.

APPENDIX D – POWER OF CHOICE EXEMPT AREAS

Foreword

The information in this Appendix is for Power of Choice exempt areas only i.e. not connected to the National Electricity Market (non-NEM). This includes all remote generation sites and the Mt Isa Network.

For Power of Choice areas i.e. connected to the National Electricity Market (NEM), refer to Sections 6 to 8.

This Appendix must be read in conjunction with Sections 6 to 8 as only those items unique to non-NEM areas are listed here.

D.1 Metering Requirements

D.1.1 General

Basic metering arrangements are shown in this Appendix.

Note: The *distributor* is the *metering provider* for all metering installations in non-NEM areas.

Any variations to the standard metering practice require prior approval in writing (i.e. the *metering provider* must be contacted if an enhanced metering scheme is required for complex installations).

D.1.2 Direct Connected Metering

Single phase *direct connected* kilowatt-hour meters shall be used for all single phase metering and polyphase meters shall be used for all single tariff two and three phase metering (Refer to Clause 4.1).

D.1.3 Controlled loads

Initial Connections – Where the initial connection request is for a single phase two tariff installation (general supply plus a *controlled supply*), provision for a *two element* single phase meter and separate *network device* shall be made (Refer to Drawing QECMM D.14).

Additions and Alterations – Where a *controlled supply* is added to a single phase installation with an existing single element single phase meter (general supply), provision for an additional single element single phase meter and separate *network device* shall be made (Refer to Drawing QECMM D.11).

Limited space installations – Where a *controlled supply* is added to an existing installation where there is limited space on the meter panel, provision for a *two element* single phase meter and separate *network device* can be made (Refer to Drawing QECMM D.14).

Note:

In designated areas where AF signal is not available, the *metering provider* will supply *two element meters* with built-in time clocks where load switching of permanently connected loads are required as part of supply conditions. Information on areas designated as having no AF signal can be obtained by contacting the *distributor*. (Refer to Clause 6.7 and page 1 for contact details).

D.1.4 Plug-in Metering

Except in the areas described in Section D.1.5, plug-in kilowatt hour meters are only available on existing installations where the plug-in type bases are already installed.

D.1.5 Card Operated Metering

In Ergon Energy's Far North Queensland region, card operated meters (COMs) will be supplied for designated remote communities and most isolated generation sites in the Torres Strait Islands.

The majority of single phase *card operated meters*, are supplied as plug-in meters and require a plug-in meter socket to be provided and installed by the *customer* (3 jaw with A, N & L terminals for single tariff installations and 4 jaw with A, N, L & 1 terminals for two tariff installations) Refer to AS 1284 part 4 figure 2.1. Ergon Energy stock recovered plug-in sockets for use by *Electrical Contractors* who cannot source these items.

Card operated meters are progressively being converted to bottom connected meters (by community) and hence will no longer require the supply and installation of a plug-in socket. Contact *Ergon Energy* to ascertain if a plug-in socket is required.

Commercial installations requiring special tariffs or *current transformer metering* will not use *card operated meters*.

Temporary Builder's Supplies in *card operated meter* areas shall have *card operated meters* installed with commercial tariffs to apply.

Requests for exemptions can be lodged for critical loads (e.g. sewerage pumps, unmanned communications sites etc) so that *card operated meters* are not used (refer to Clause 1.4).

A metering isolation link is required to be installed on the line side of all *card operated meters*. (Refer to Clauses 6.6.1.1 & 6.6.2).

In general Ergon Energy will provide one service to a community title scheme or cluster development installation with *card operated meters*.

Where a cluster or community title scheme development with *card operated meters* consists of a number of tenanted buildings a meter position located on common ground for each building may be permitted.

The following meter positions will also be acceptable:

(i) The main switchboard located on common ground and all metering equipment installed at this position.

(ii) The main switchboard and the first metering point located on common ground and subsequent metering points located either on each building or as otherwise approved by Ergon Energy.

Note: - A single community meter position is preferred, however approval may be granted for an additional community meter where a single position is not practical. Each community meter will be treated as a separate account for billing purposes.

To clarify the required metering type in the remote communities and isolated generation sites in Far North Queensland contact *Ergon Energy Customer Service*. (Refer to page 1 for contact details).

D.1.6 SWER Installation Metering

For rural *customers* connected to Single Wire Earth Return (SWER) networks, the metering shall be connected as per TABLE D.1.

TABLE D.1

Voltage of Secondary Supply	Supply Capacity	Metering Configuration	Reference Drawing
240V	<= 25kVA (90A)	<i>Direct connected</i> 1 x single phase meter	QECMM - D.2
240V	> 25kVA	Current transformer 1 x three phase meter	QECMM - D.3
480V	<= 50kVA (180A) (Load split across phases @ <= 90A/phase)	<i>Direct connected</i> 1 x three phase meter	QECMM - D.5
480V	> 50kVA	Current transformer 1 x three phase meter	QECMM - D.4

Note: 480V supply is not available within the Energex distribution area.

D.1.7 Time Switches

Separate time switches will not be used for any new metering installations.

For controlled supplies in designated areas without suitable AF signal, the *metering provider* will supply a *two element* meter with an internal time switch. (Refer to TABLE 6.1 for space requirements). *Two element meters* may have one or two switches internal to the meter that are associated with one *controlled supply* (Refer to Drawings QECMM D.13 and D.19).

Within the *Ergon Energy* distribution area this includes all isolated generation sites at Bedourie, Birdsville, Boulia, Camooweal, Jundah, and Windorah. *Electrical contractors* should contact the *distributor* for details of other areas. (Refer to page 1 for contact details).

D.1.8 Current Transformer Metering

Electronic polyphase kilowatt-hour meters shall be used for all new *current transformer metering*. Space requirements are shown in TABLE 6.1 and drilling details in Drawing QECMM D.23.

Note: For details of *current transformer metering* refer to Section 6.

D.2 Installation Requirements for Meters and Control Equipment

D.2.1 Connection of Direct Connected Metering

The neutral conductor of the *consumer's mains* is not to be joined or looped through the terminals of a revenue meter or metering link.

Metering neutral conductors shall not be looped between metering equipment and when alterations or additions are done on existing installations with neutral looping, the looping must be removed and a metering neutral link installed.

Not more than one active conductor may be connected to any one line side terminal of a *direct connected meter*, except where parallel conductors no larger than 10mm² are used.

Supply to a secondary (*controlled load*) meter shall be from the load side of the metering isolation link. Looping of active conductors from a *controlled supply* meter to any other meter is not permitted.

A maximum of two conductors may be connected to the load terminal of a *controlled load* meter in lieu of a soldered connection when connecting two switches of a multi-switch *network device*. (Refer to Drawing QECMM D.11). Looping between *network devices* is not permitted.

Looping of active conductors on the line side between meters is not permitted. Where more than two active conductors are required to supply *direct connected meters* or where a circuit breaker is installed on the line side of the metering in accordance with Clause 6.6.1.1, an active meter link may be required to be installed. (Refer to Clause 6.7.4).

All meter wiring shall be supplied and installed by the *electrical contractor* and suitable holes provided in the meter panel (ready for connection by the *metering provider*). Cable tails through meter panels should be a minimum 150mm for connection and termination to metering equipment.

Where additional metering equipment is to be installed on an existing installation, care must be taken to ensure any additional meter wiring provided for later installation of meters, is suitably terminated.

Taping of conductors on the front of a meter panel does not satisfy the requirements of AS/NZS 3000 (Wiring Rules) as a suitable means of termination.

D.2.2 Size of Direct Connected Meter Wiring

The meter wiring for *direct connected metering* shall be PVC insulated copper cable from these standard sizes:

4mm ²	7/0.85
6mm ²	7/1.04
10mm ²	7/1.35
16mm ²	7/1.70

Insulated flexible cables are approved for use for 10, 16 & 25mm² provided that one long or two short soft-form un-insulated bootlace pins (end sleeves) are securely crimped snugly against each other onto each cable tail by the *electrical contractor*. The use of two bootlace pins per cable tail will allow the use of standard length pins while still allowing the required length to maintain secure connection to the meter terminal screws. Upon installation by the *Distributor*, any excess length of pins will be trimmed to suit the depth of the meter being used. An appropriate crimping tool must be used. (Refer to AS/NZS 3000 (Wiring Rules)).

Active and load meter wiring for *direct connected metering* shall not exceed 25mm². (Refer to Clause D.2.1 for parallel conductors connected to meter terminals).

Compressed (compacted) or hard drawn conductors shall not be used as meter wiring (must be flexible enough to bend into the meter terminals).

Aluminium cables are not permitted for connection directly into meter terminals.

D.3 Controlled Supplies - Method of Control

D.3.1 Network Devices

Single phase installations with *controlled supplies* shall be connected in accordance with Drawings:

- QECMM D.14, D.20 and D.21 (Initial connection and limited space use) or;
- QECMM D.11, D.16 and D.18 (Additions and alterations only) or;
- QECMM D.13 and D.19 (Non-ripple control areas only)

Multiple installations where multi-switch *network devices* are utilised must be provided with a *network device* switch per *customer* in accordance with Drawing QECMM D.22 (Initial connection and limited space use) or QECMM D.17 (Additions and alterations only). Switching of individual *customer's* hot water by the use of contactors is not permitted.

Notes:

1. Connections to multi-switch *network devices* shall be clearly labelled to identify the switch applicable to each *customer*.
2. A separate metering isolation link is to be used for supply to the *network device(s)*. Where more than one switch per *customer* is required then an individual *network device* per *customer* shall be used.

D.4 Installation Requirements for Low Voltage Current Transformer Metering

D.4.1 Current Transformers – When Required

The *customer* shall make provision for the installation of *current transformer metering* where the calculated maximum demand of the load to be metered exceeds 120A per phase as determined in accordance with the guidelines given in AS/NZS 3000 (Wiring Rules). *Current transformer metering* shall be used for actual loads greater than 90A or motors larger than 50kW (65hp).

Unless otherwise advised by the *distributor*, *direct connected meters* rated up to 100A will be supplied for loads less than these values.

For new installations or installations with additional load, the *metering provider* will not supply one *customer* with multiple sets of *directly connected meters* on the same supply type (e.g. general supply) at the same *connection point* in lieu of *current transformer metering*.

D.4.2 Meter Panels for Current Transformer Metering

Maximum distances and required conductor sizes for meter panels installed remote from the switchboard can be determined from TABLE D.2.

QLD Electricity Connection and Metering Manual



Part of the Energy Queensland Group

TABLE D.2

Rated Burden	Max Circuit Length 2.5 mm ²	Max Route Length 2.5 mm ²	Max Circuit Length 4mm ²	Max Route Length 4 mm ²	Max Circuit Length 6 mm ²	Max Route Length 6 mm ²
5 VA	15m	7.5m	25m	12.5m	36m	18m
15 VA	45m	22.5m	80m	40m	—	—
<p>Note: 200/5 ratio CTs are supplied with a rated burden of 5 VA 800/5 and 1500/5 ratio CTs are supplied with a rated burden of 15 VA.</p>						

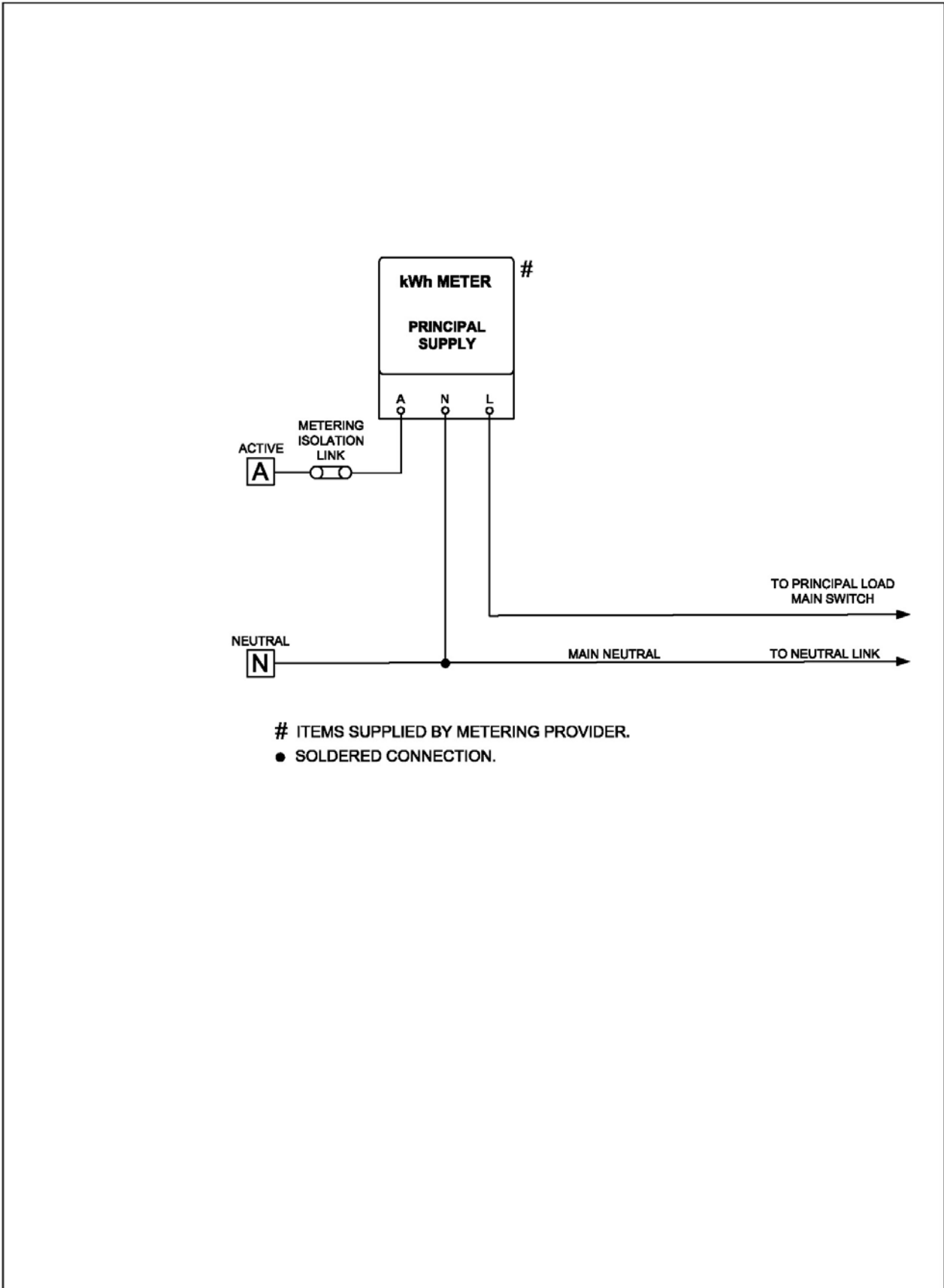

Revision: A	WIRING DIAGRAM - DIRECT CONNECTED METERING SINGLE PHASE PRINCIPAL SUPPLY ONLY	QECMM - D.1
------------------------------	--	--------------------

ARRANGEMENT SUITABLE FOR NET IES METERING

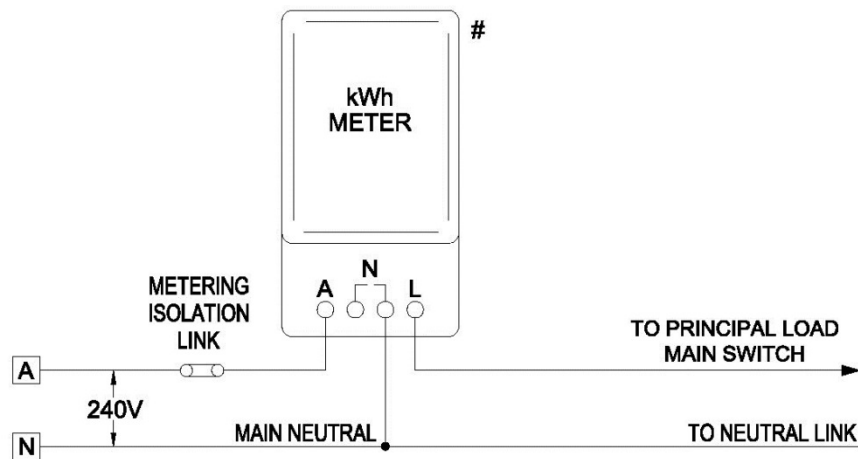

- # ITEMS SUPPLIED BY METERING PROVIDER
- SOLDERED CONNECTION

Revision:

A

**WIRING DIAGRAM - DIRECT CONNECTED METERING
240 VOLT SWER CONFIGURATION**

QECMM - D.2

ARRANGEMENT SUITABLE FOR NET IES METERING

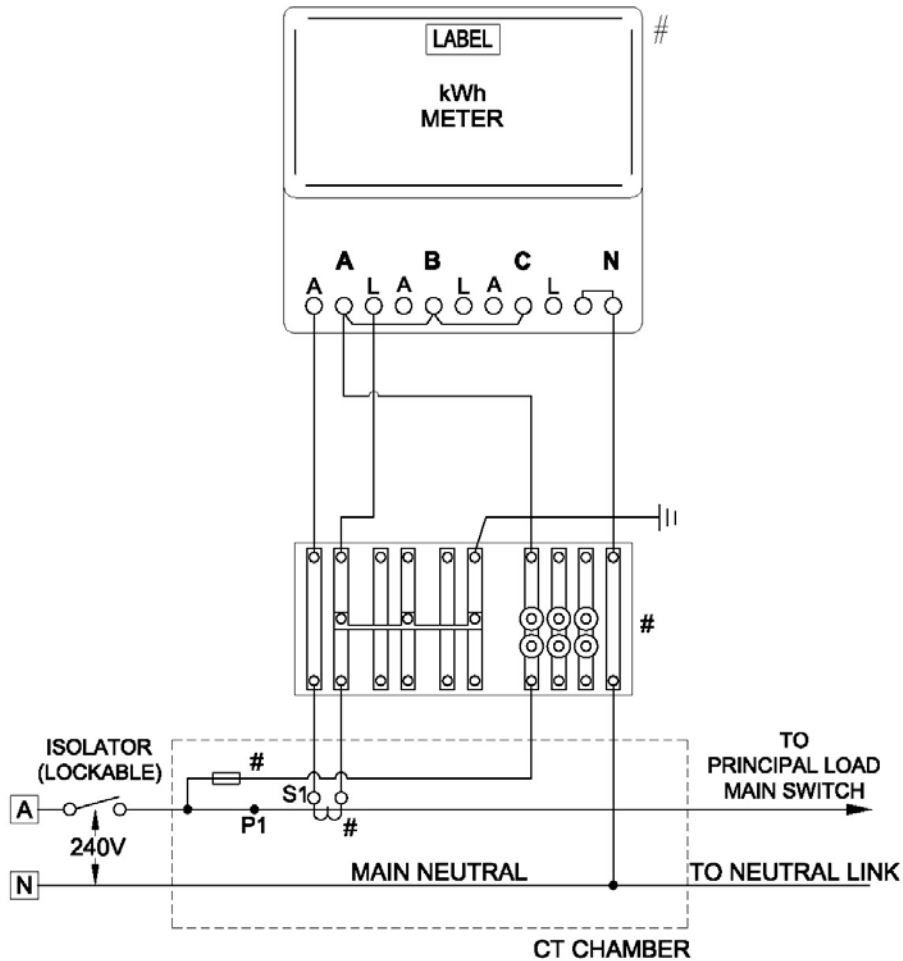

ITEMS SUPPLIED BY METERING PROVIDER
 • SOLDERED CONNECTION

NOTES

1. CT'S TO BE CONNECTED TO 'A' PHASE TERMINALS OF POLYPHASE CT METER.
2. 'B' & 'C' PHASE VOLTAGE TERMINAL OF METER TO BE BRIDGED TO 'A' PHASE VOLTAGE TERMINAL - ERGON ENERGY ONLY.

Revision:

A

**WIRING DIAGRAM - CURRENT TRANSFORMER METERING
 240 VOLT SWER CONFIGURATION**

QECMM - D.3

ERGON ENERGY ONLY ARRANGEMENT SUITABLE FOR NET IES METERING

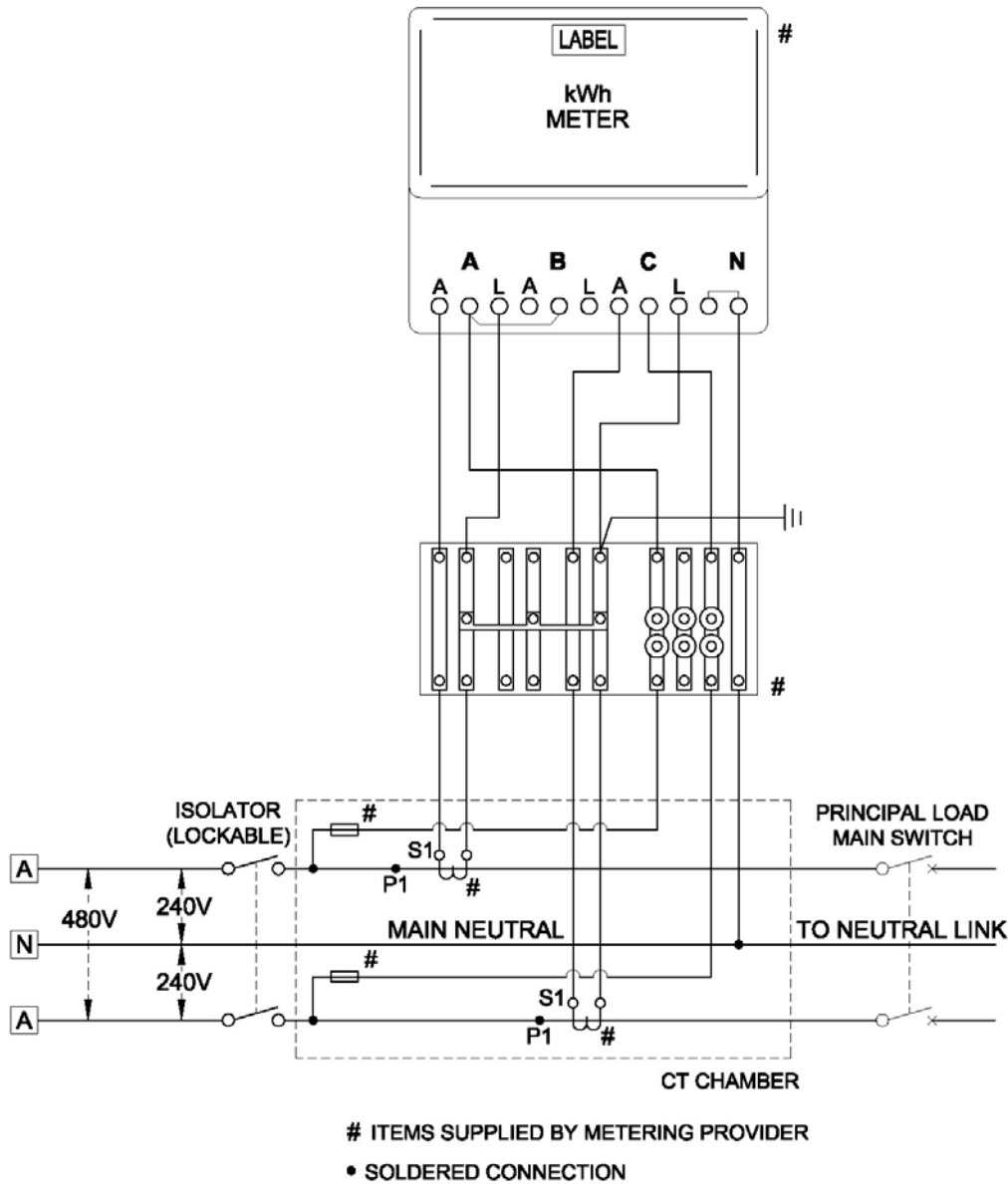

NOTES:

1. CT'S TO BE CONNECTED TO 'A & C' PHASE TERMINALS OF POLYPHASE CT METER.
2. 'B' PHASE VOLTAGE TERMINAL OF METER TO BE BRIDGED TO 'A' PHASE VOLTAGE TERMINAL - ERGON ENERGY ONLY.
3. 480V SUPPLY IS NOT AVAILABLE WITHIN THE ENERGEX DISTRIBUTION AREA.

Revision:
A

**WIRING DIAGRAM - CURRENT TRANSFORMER METERING
480 VOLT SWER CONFIGURATION**

QECMM - D.4

ERGON ENERGY ONLY ARRANGEMENT SUITABLE FOR NET IES METERING

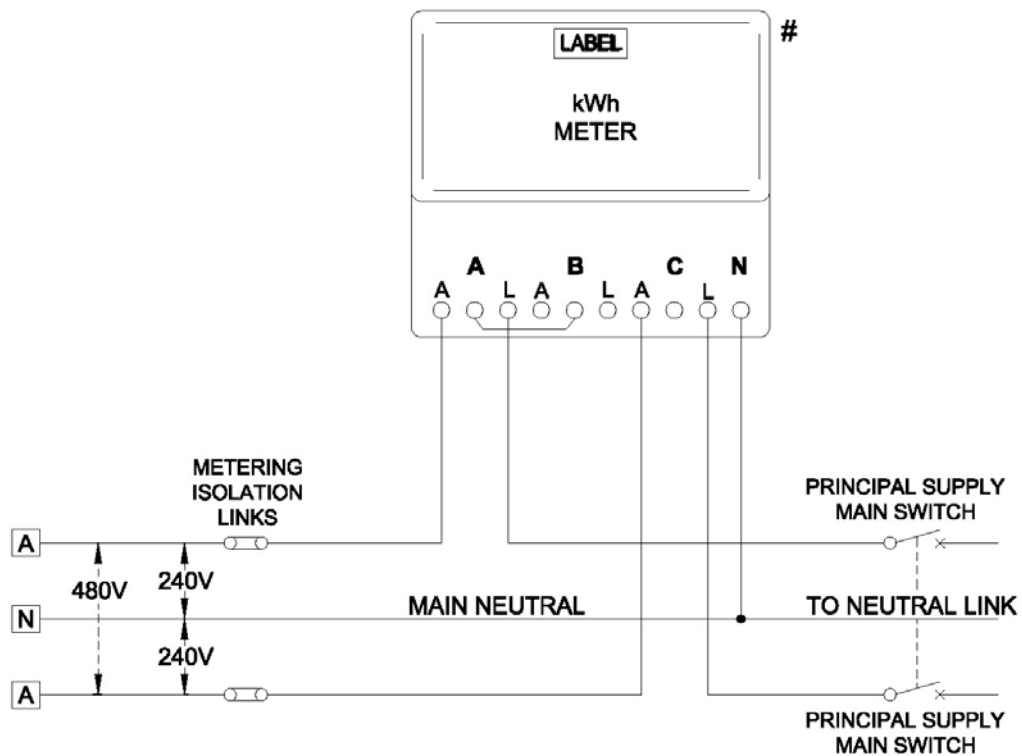

ITEMS SUPPLIED BY METERING PROVIDER.
• SOLDERED CONNECTION

NOTES:

1. 'B' PHASE VOLTAGE TERMINAL OF METER TO BE BRIDGED TO 'A' PHASE VOLTAGE TERMINAL - ERGON ENERGY ONLY.
2. FOR IES/SOLAR SCHEME APPLICATIONS A BI-DIRECTIONAL METER IS REQUIRED TO RECORD IMPORT/EXPORT ENERGY
3. 480V SUPPLY IS NOT AVAILABLE WITHIN THE ENERGEX DISTRIBUTION AREA.

Revision:

A

**WIRING DIAGRAM - DIRECT CONNECTED METERING
480 VOLT SWER CONFIGURATION**

QECMM - D.5

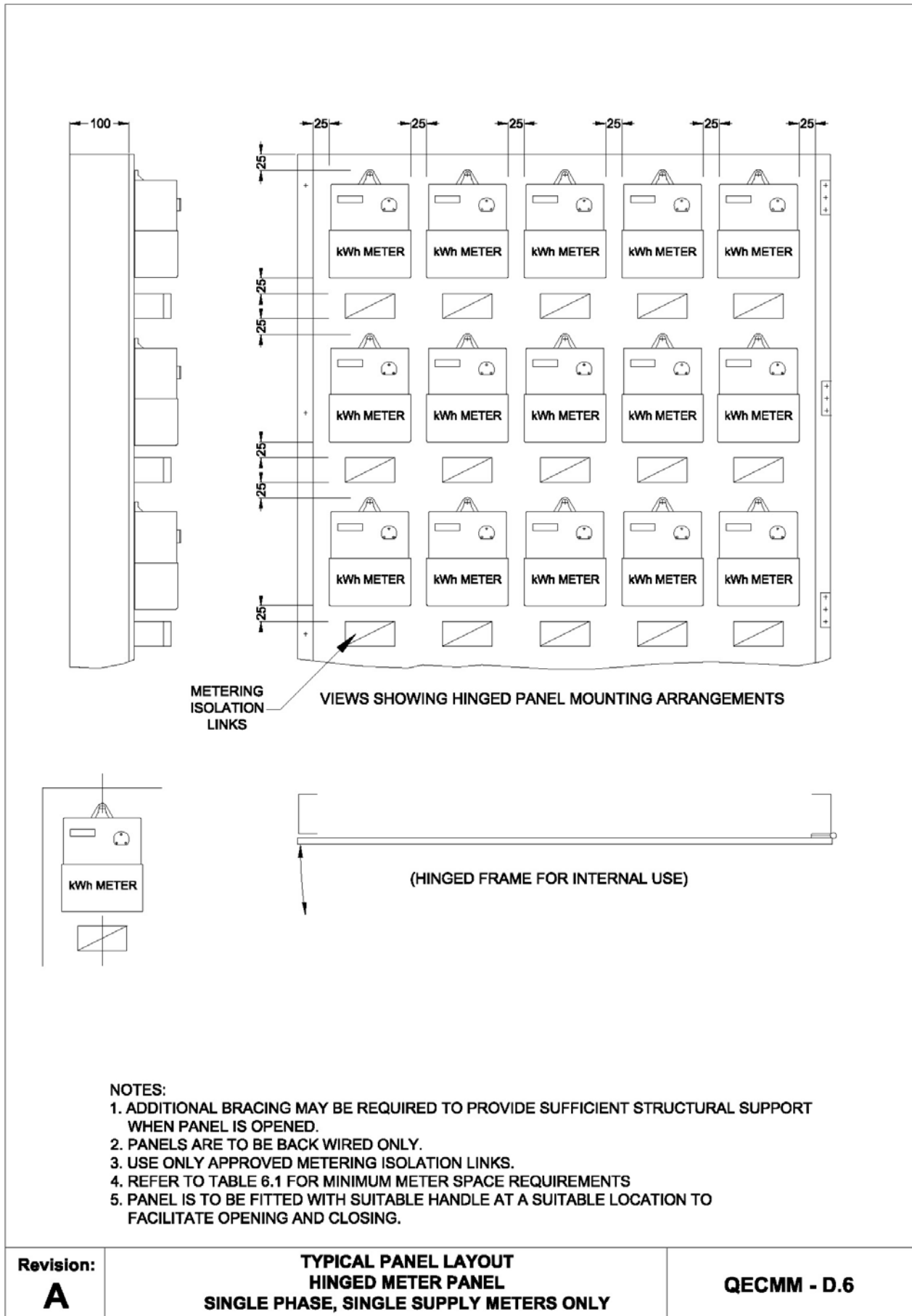

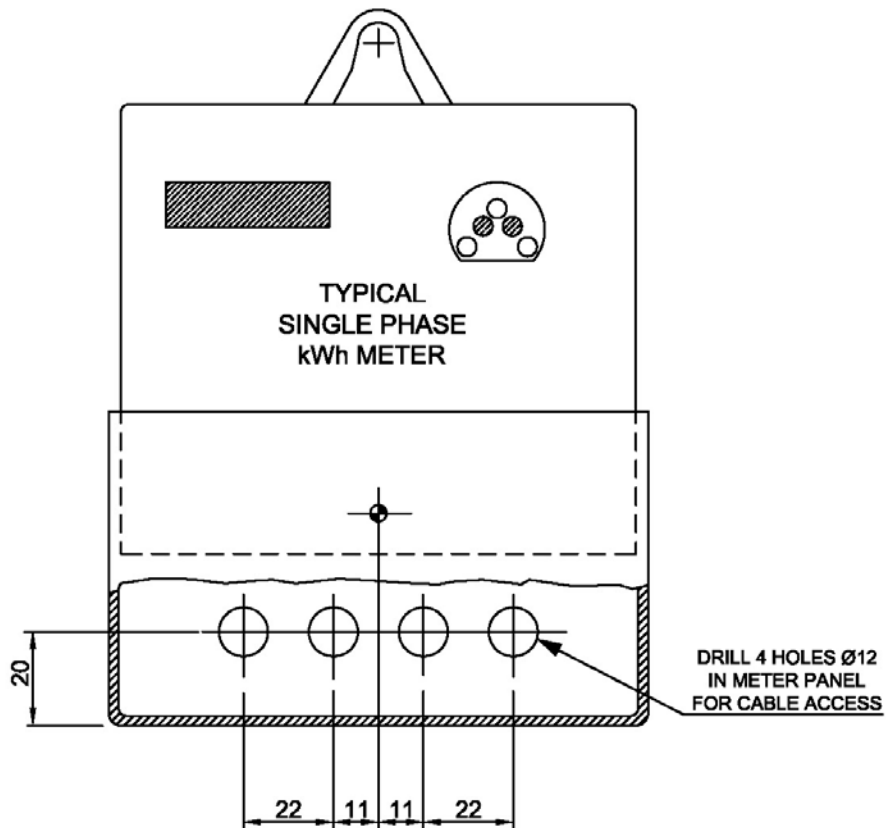

Revision: A	DRILLING DETAILS FOR CABLE ACCESS SINGLE PHASE kWh METER	QECMM - D.7
------------------------------	---	--------------------

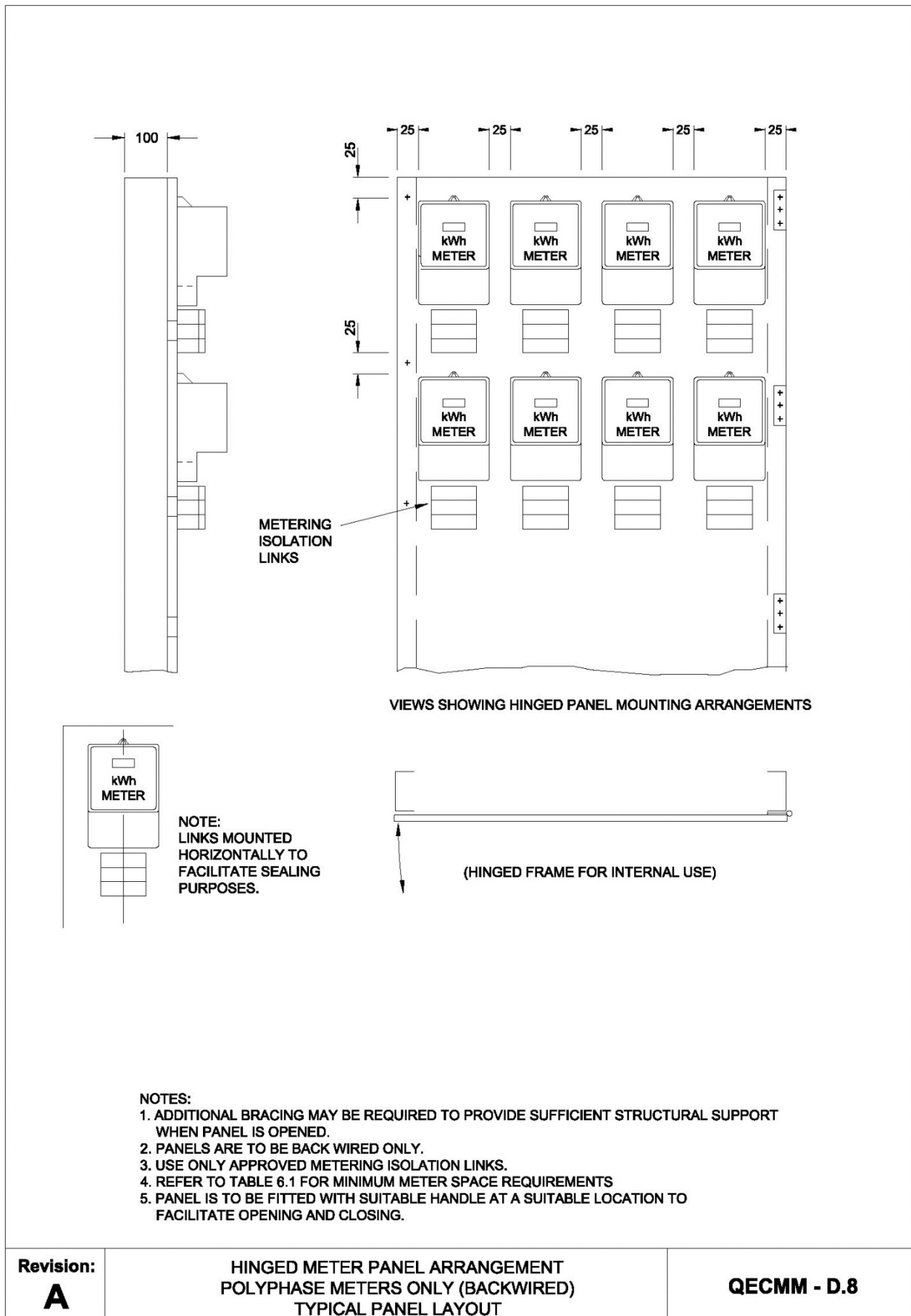

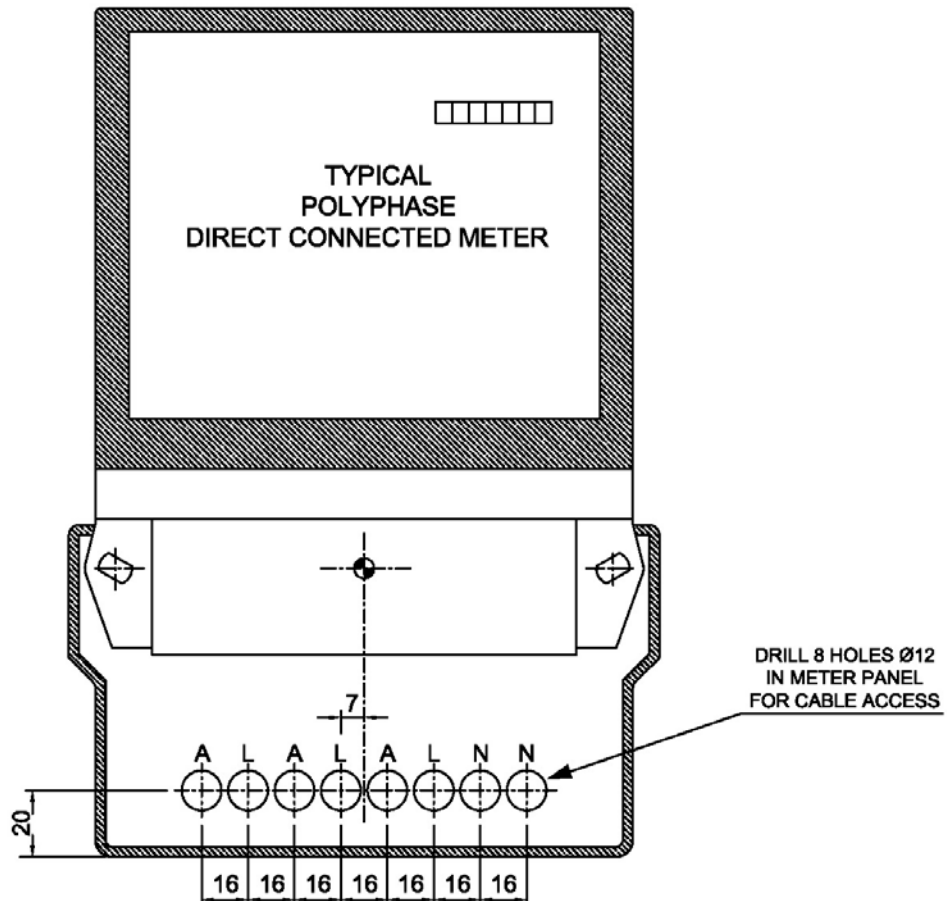

Revision: A	DRILLING DETAILS FOR CABLE ACCESS POLYPHASE DIRECT CONNECTED kWh METER	QECMM - D.9
------------------------------	---	--------------------

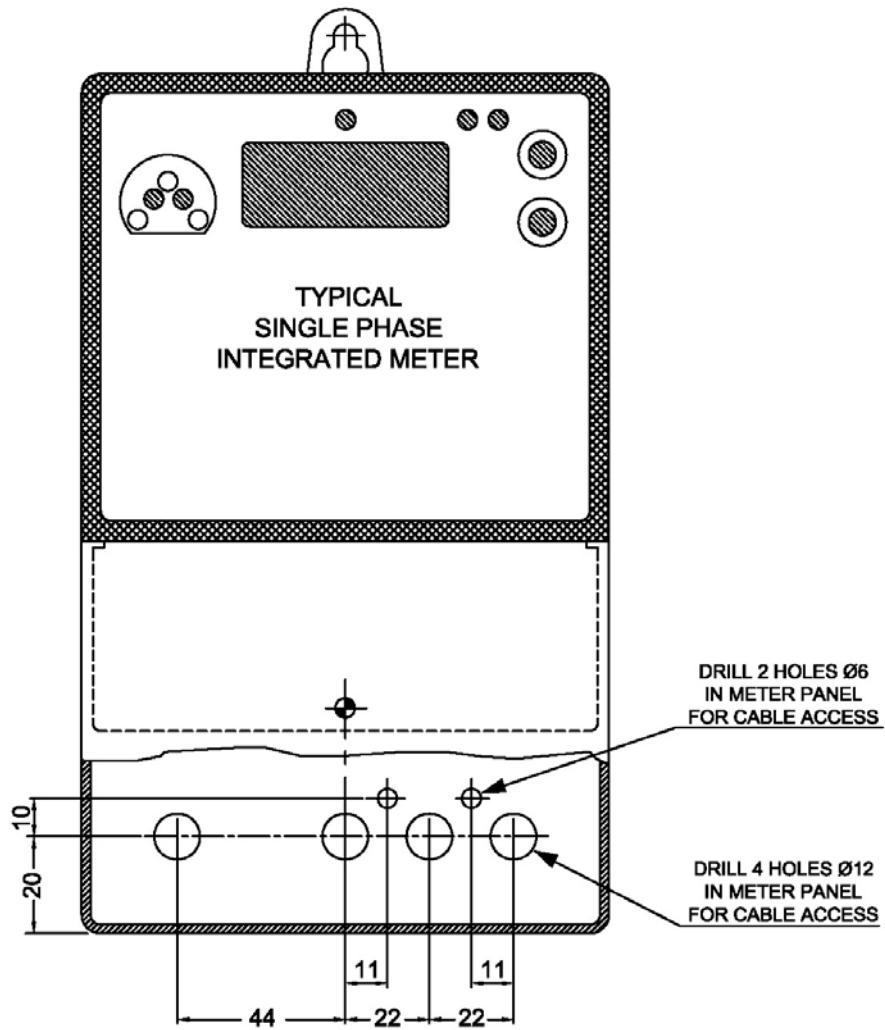

Revision: A	DRILLING DETAILS FOR CABLE ACCESS SINGLE PHASE kWh METER (INTEGRATED)	QECMM - D.10
------------------------------	--	---------------------

ADDITIONS AND ALTERATIONS ONLY

INCLUDES LOAD, OTHER THAN WATER HEATING LOAD, WHERE THE RESISTIVE LOAD DOES NOT EXCEED 30A OR WHERE RESISTIVE AND INDUCTIVE LOAD DOES NOT EXCEED 20A

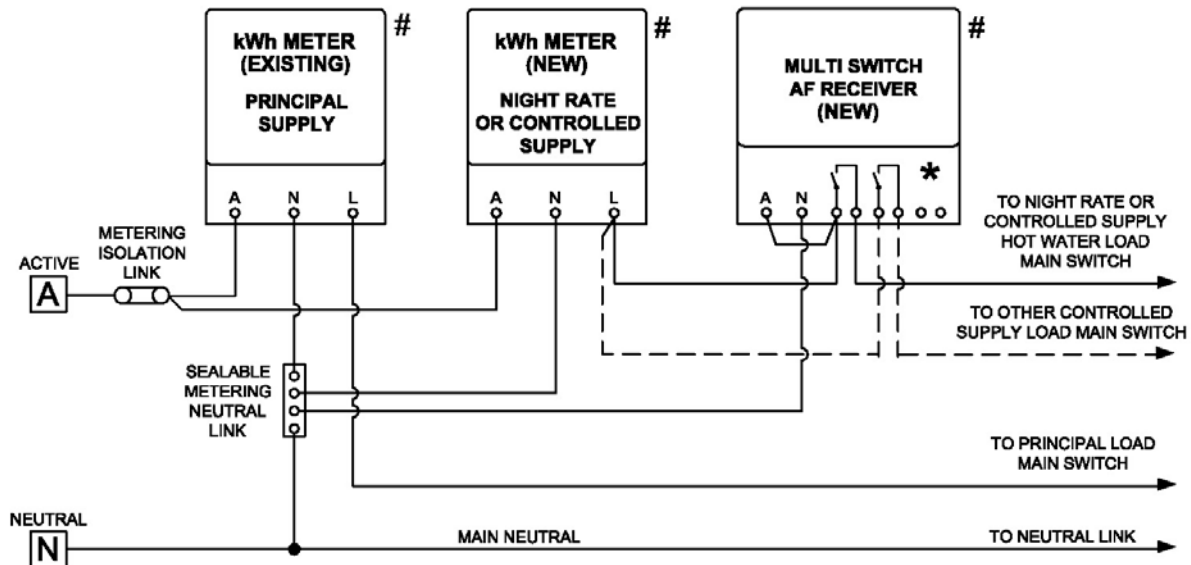

ITEMS SUPPLIED BY METERING PROVIDER.

* SWITCH POSITION DETERMINED BY SUPPLY AND LOAD TYPE.

● SOLDERED CONNECTION.

NOTES:

1. FOR CONTROLLED SUPPLY LOADS, WHERE RESISTIVE LOAD EXCEEDS 30A OR WHERE RESISTIVE AND INDUCTIVE LOAD EXCEEDS 20A, A CONTACTOR SHALL BE USED. SEE DRAWING QECMM D.18.
2. APPLIANCES CONNECTED TO THE CONTROLLED LOAD CIRCUITS MUST BE PERMANENTLY CONNECTED, AND FOR APPLIANCES SUCH AS DISHWASHERS THE INSTALLATION OF AN ISOLATING SWITCH WITH NEON INDICATOR IS RECOMMENDED.
3. OTHER CONTROLLED SUPPLY LOAD CANNOT BE CONNECTED IN CONJUNCTION WITH NIGHT RATE LOAD ON THE ONE METER (REFER TO DRAWING QECMM D.16).

Revision: A	WIRING DIAGRAM - DIRECT CONNECTED METERING SINGLE PHASE PRINCIPAL SUPPLY PLUS NIGHT RATE OR CONTROLLED SUPPLY (ADDITIONS AND ALTERATIONS ONLY)	QECMM - D.11
------------------------------	---	---------------------

TWO PHASE SUPPLY/SERVICE WITH OPTIONAL LOAD CONTROL

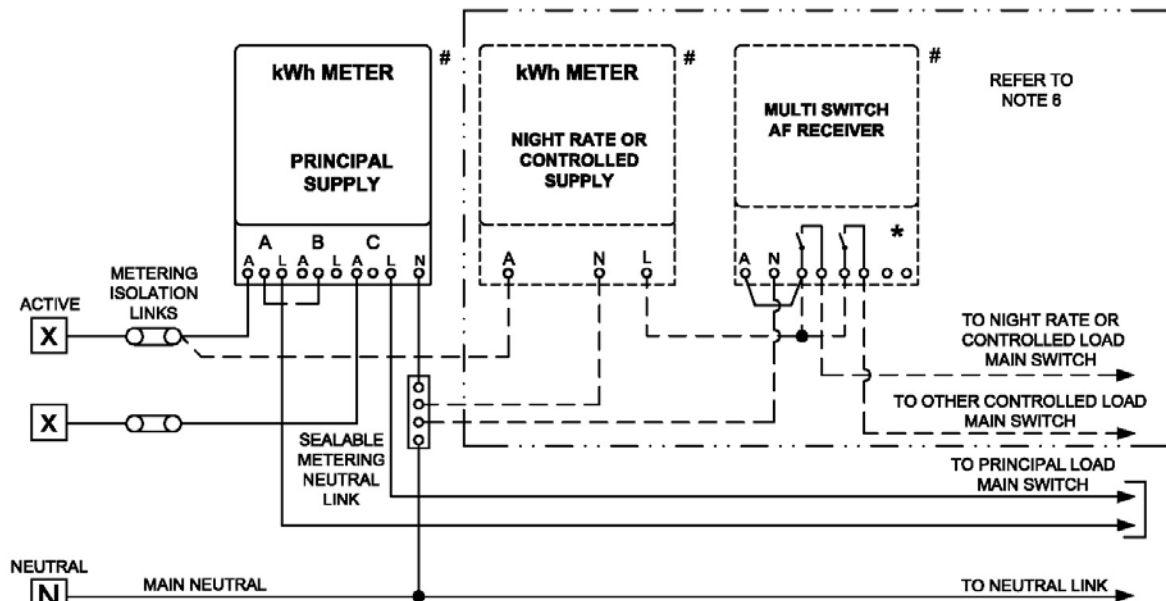

ITEMS SUPPLIED BY METERING PROVIDER.
 * SWITCH POSITION DETERMINED BY SUPPLY AND LOAD TYPE.
 ● SOLDERED CONNECTION.

NOTES:

1. FOR CONTROLLED SUPPLY LOADS, WHERE RESISTIVE LOAD EXCEEDS 30A OR RESISTIVE AND INDUCTIVE LOAD EXCEEDS 20A, A CONTACTOR SHALL BE USED. SEE DRAWING QECMM D.18.
2. 'A' PHASE VOLTAGE TERMINAL OF METER TO BE BRIDGED TO 'B' PHASE VOLTAGE TERMINAL -ERGON ENERGY ONLY.
3. TWO PHASE SUPPLY CONNECTED TO 'A' AND 'C' PHASE TERMINALS OF POLYPHASE METER.
4. IN NON-RIPPLE CONTROL AREAS, THE SINGLE kWh METER/AF RECEIVER COMBINATION TO BE REPLACED WITH A 2 ELEMENT METER. SEE DRAWING QECMM D.13
5. DOTTED LINES INDICATE VARIOUS CONTROL OPTIONS.

Revision: A	WIRING DIAGRAM - NET METERING SCHEMES TWO PHASE SERVICE PRINCIPAL SUPPLY PLUS OPTIONAL LOAD CONTROL	QECMM - D.12
------------------------------	--	---------------------

NON-RIPPLE CONTROL AREAS ONLY

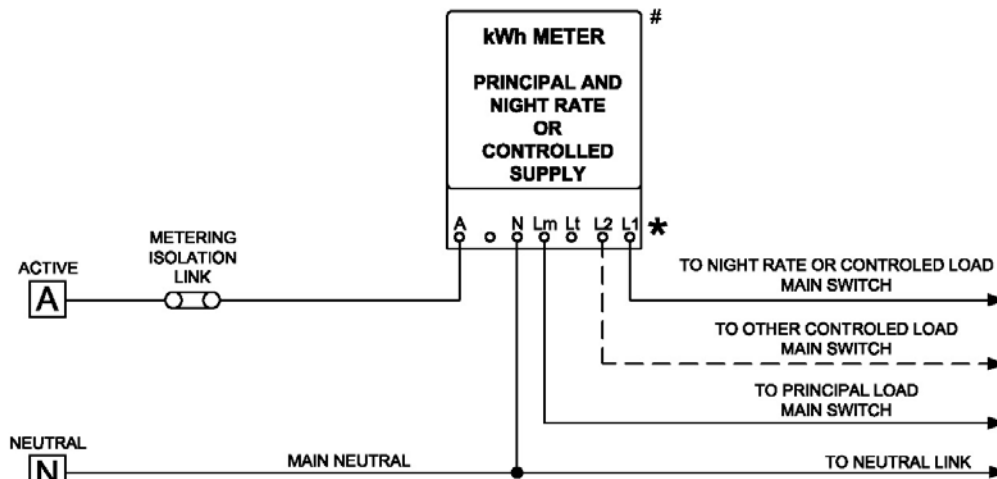

- # ITEMS SUPPLIED BY METERING PROVIDER.
- * SWITCH POSITION DETERMINED BY SUPPLY AND LOAD TYPE.
- SOLDERED CONNECTION.

NOTES:

1. THIS ARRANGEMENT APPLIES TO NON-RIPPLE CONTROL AREAS
2. WHERE RESISTIVE LOAD EXCEEDS 30A OR WHERE RESISTIVE AND INDUCTIVE LOAD EXCEEDS 20A, A CONTACTOR SHALL BE USED. SEE DRAWING QECMM D.19 .
3. CONTROLLED CIRCUIT ASSOCIATED WITH SECONDARY SUPPLIES CONNECTED TO SWITCHED TERMINALS L1/L2 OF TWO ELEMENT METER.
4. TWO ELEMENT METER TERMINAL DESCRIPTION.

1	A - ACTIVE IN
3	N - NEUTRAL IN
4	Lm - ELEMENT 1 (MAIN)
5	Lt - ELEMENT 2 (UNSWITCHED)
6,7	L1 & L2 ELEMENT 2 (SWITCHED)

Revision:

A

**SINGLE PHASE 2-ELEMENT METER
DIRECT CONNECTED METERING
PRINCIPAL & CONTROLLED SUPPLIES (TYPICAL WIRING DIAGRAM)
(NON-RIPPLE CONTROL AREAS ONLY)**

QECMM - D.13

INITIAL CONNECTION AND LIMITED SPACE USE

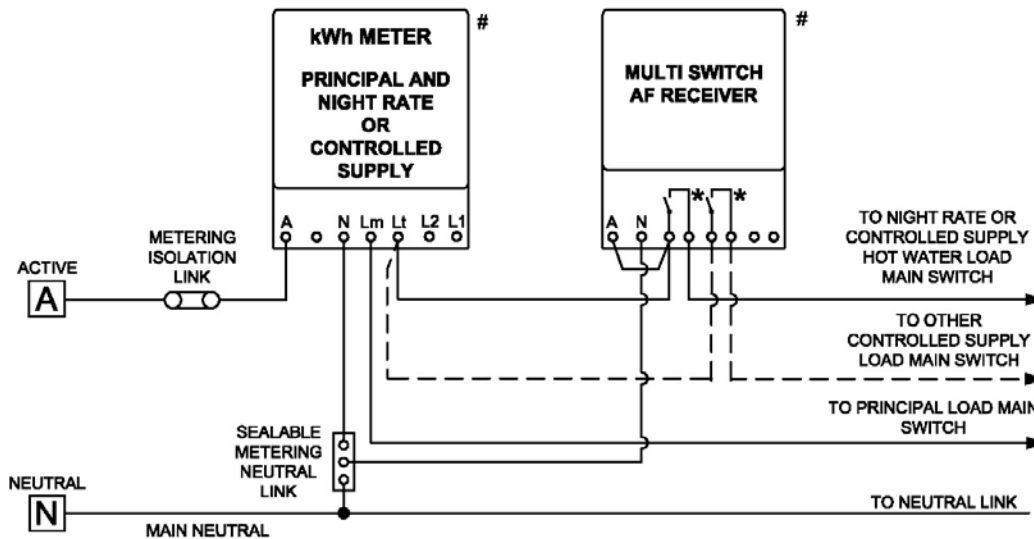

- # ITEMS SUPPLIED BY METERING PROVIDER.
- * SWITCH POSITION DETERMINED BY TARIFF AND LOAD TYPE.
- SOLDERED CONNECTION

NOTES:

1. FOR CONTROLLED SUPPLY LOADS, WHERE RESISTIVE LOAD EXCEEDS 30A OR WHERE RESISTIVE AND INDUCTIVE LOAD EXCEEDS 20A, A CONTACTOR SHALL BE USED. SEE DRAWING QECMM D.20.
2. ELEMENT 1 FOR PRINCIPAL SUPPLY ONLY, ELEMENT 2 FOR EITHER CONTROLLED OR NIGHT RATE SUPPLIES.
3. SECONDARY TARIFF SWITCHING IS DONE BY AF RECEIVER.
4. CONTROLLED CIRCUIT ASSOCIATED WITH SECONDARY SUPPLY CONNECTED TO UNSWITCHED TERMINAL L1.
5. TWO ELEMENT METER TERMINAL DESCRIPTION.

1	A - ACTIVE IN
3	N - NEUTRAL IN
4	Lm - ELEMENT 1 (MAIN)
5	Lt - ELEMENT 2 (UNSWITCHED)
6, 7	L1 & L2 - NOT USED IN RIPPLE AREAS

6. A METERING ISOLATION CIRCUIT BREAKER MAY BE USED IN LIEU OF A METERING ISOLATION LINK. (REFER TO CLAUSE 6.6.1).
7. ELEMENT 1 FOR PRINCIPAL SUPPLY LOAD ONLY, ELEMENT 2 FOR EITHER NIGHT RATE OR CONTROLLED SUPPLY LOAD.
8. OTHER CONTROLLED SUPPLY LOAD CANNOT BE CONNECTED IN CONJUNCTION WITH NIGHT RATE LOAD ON THE ONE METER (REFER TO DRAWING QECMM D.21).

Revision:

A

**WIRING DIAGRAM - DIRECT CONNECTED METERING
SINGLE PHASE PRINCIPAL SUPPLY PLUS
NIGHT RATE OR CONTROLLED SUPPLY
(INITIAL CONNECTION AND LIMITED SPACE USE)**

QECMM - D.14

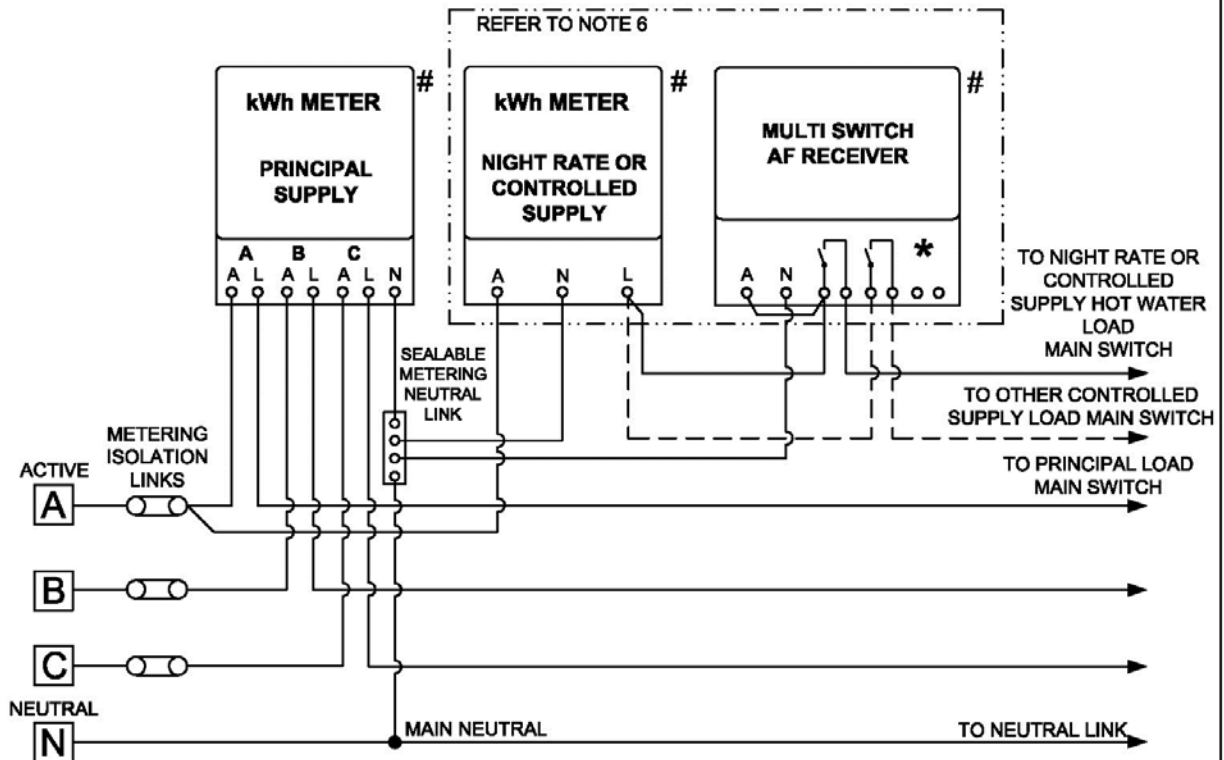

- # ITEMS SUPPLIED BY METERING PROVIDER.
- * SWITCH POSITION DETERMINED BY SUPPLY AND LOAD TYPE.
- SOLDERED CONNECTION.

NOTES:

1. FOR CONTROLLED SUPPLY LOADS, WHERE RESISTIVE LOAD EXCEEDS 30A OR WHERE RESISTIVE AND INDUCTIVE LOAD EXCEEDS 20A, A CONTACTOR SHALL BE USED.
2. DOTTED LINES INDICATE VARIOUS SUPPLY OPTIONS.
3. A METERING ISOLATION CIRCUIT BREAKER MAY BE USED IN LIEU OF THE METERING ISOLATION LINK REFER TO CLAUSE 6.6.1.
4. IN NON-RIPPLE CONTROL AREAS, THE SINGLE ELEMENT kWh METER / AF RECEIVER COMBINATION TO BE REPLACED WITH A 2 ELEMENT METER. SEE DRAWING QECMM D.13.
5. OTHER CONTROLLED SUPPLY LOAD CANNOT BE CONNECTED IN CONJUNCTION WITH NIGHT RATE LOAD ON THE ONE METER (REFER TO DRAWING QECMM D.16).

Revision: A	WIRING DIAGRAM - DIRECT CONNECTED METERING THREE PHASE PRINCIPAL SUPPLY PLUS SINGLE PHASE NIGHT RATE OR CONTROLLED SUPPLY	QECMM - D.15
------------------------------	--	---------------------

ADDITIONS AND ALTERATIONS ONLY

INCLUDES LOAD OTHER THAN WATER HEATING LOAD WHERE
RESISTIVE LOAD DOES NOT EXCEED 30A OR
RESISTIVE AND INDUCTIVE LOAD DOES NOT EXCEED 20A

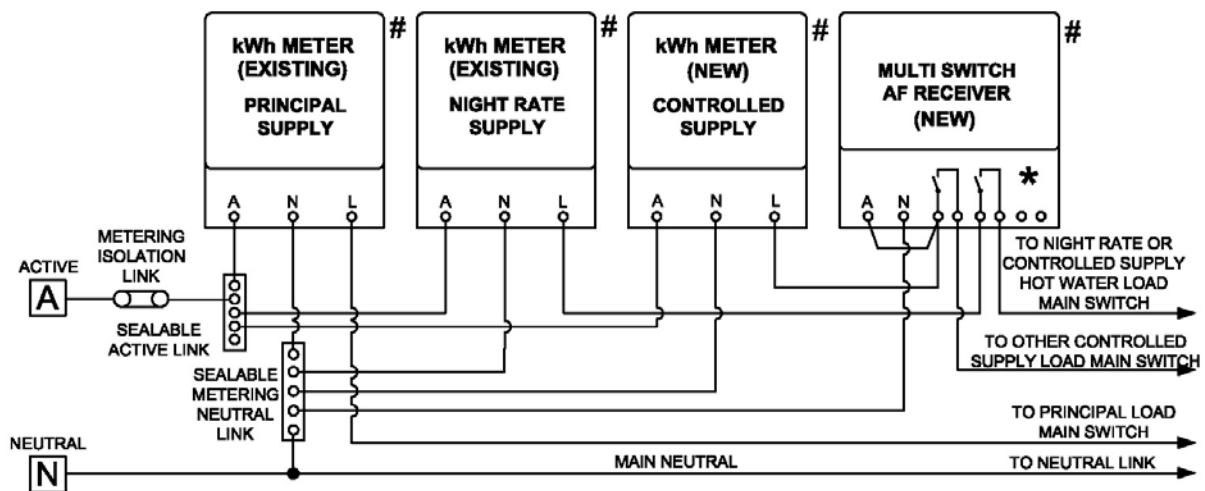

- # ITEMS SUPPLIED BY METERING PROVIDER.
- * SWITCH POSITION DETERMINED BY SUPPLY AND LOAD TYPE.
- SOLDERED CONNECTION.

NOTES:

1. FOR CONTROLLED SUPPLY LOADS, WHERE RESISTIVE LOAD EXCEEDS 30A OR WHERE RESISTIVE AND INDUCTIVE LOAD EXCEEDS 20A, A CONTACTOR SHALL BE USED. (SEE DRAWING QECMM D.18).

Revision: A	WIRING DIAGRAM - DIRECT CONNECTED METERING SINGLE PHASE PRINCIPAL SUPPLY PLUS NIGHT RATE AND CONTROLLED SUPPLIES (ADDITIONS AND ALTERATIONS ONLY)	QECMM - D.16
------------------------------	--	---------------------

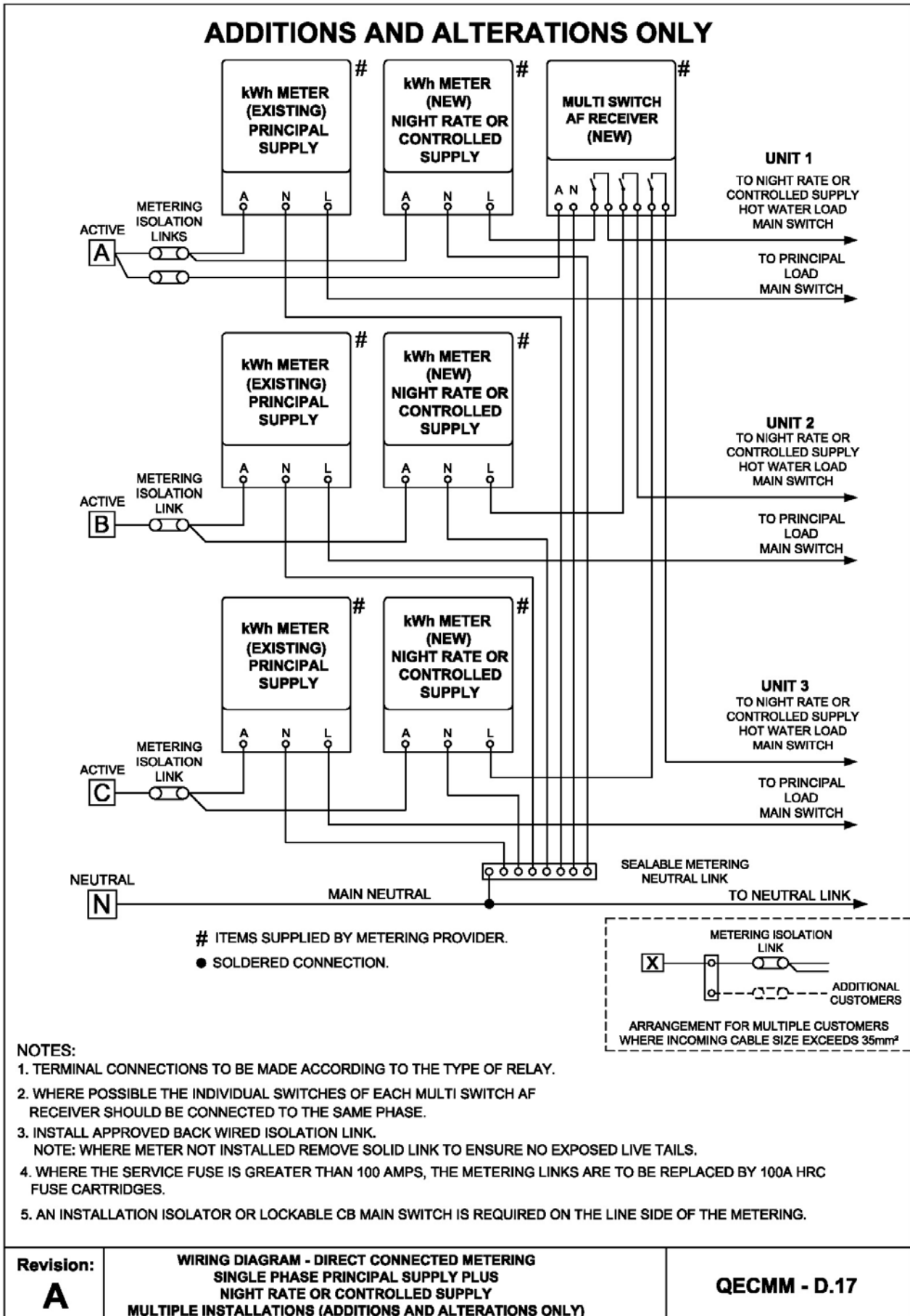

ADDITIONS AND ALTERATIONS ONLY

AF RECEIVER MULTI SWITCH CONTROL
DIRECT CONNECTED 1 PHASE METERING FOR PRINCIPAL SUPPLY WITH OPTIONAL NIGHT RATE HEATING AND OTHER CONTROLLED LOAD SWITCHED VIA CONTACTOR

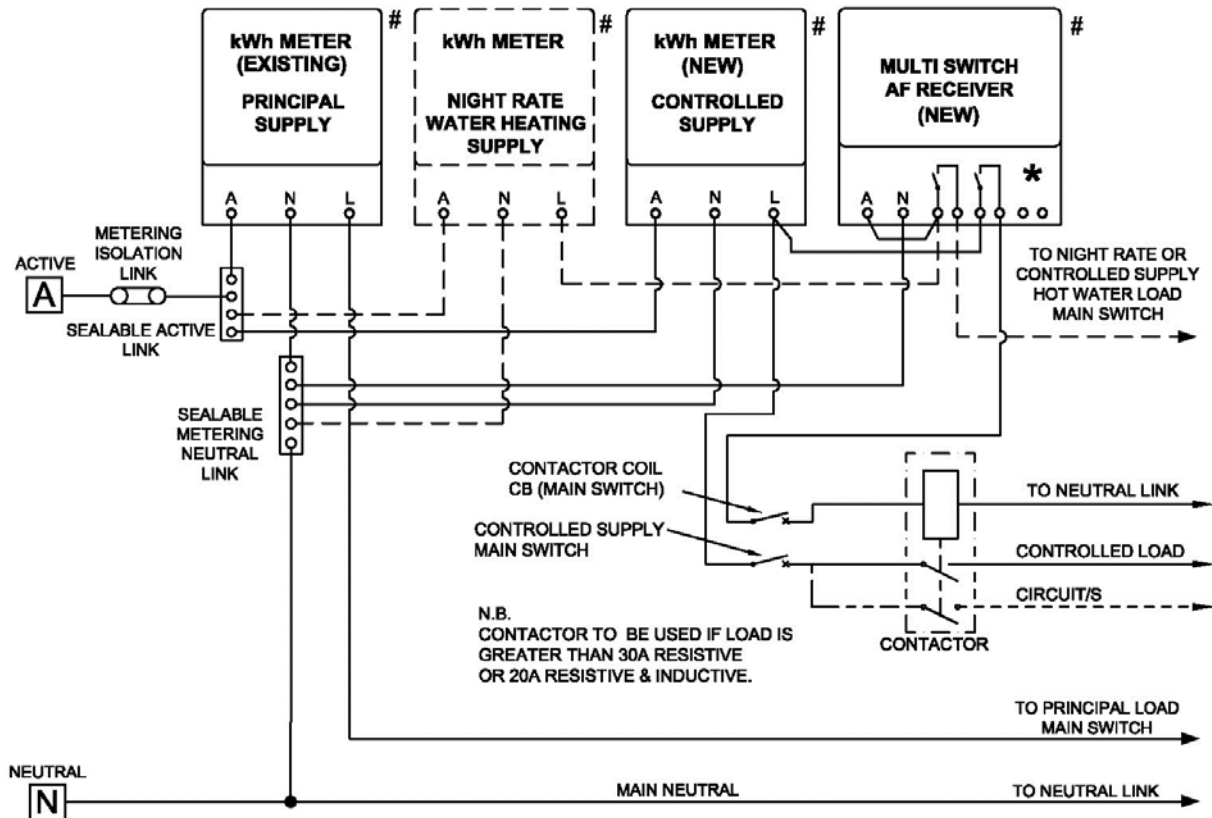

- # ITEMS SUPPLIED BY METERING PROVIDER.
- * SWITCH POSITION DETERMINED BY SUPPLY AND LOAD TYPE.
- SOLDERED CONNECTION.

NOTES:

1. CUSTOMER TO SUPPLY CONTACTOR AND ALL ITEMS NOT MARKED WITH AN "#".
2. DOTTED LINES INDICATE VARIOUS SUPPLY OPTIONS.

Revision:
A

**WIRING DIAGRAM - DIRECT CONNECTED METERING
SINGLE PHASE PRINCIPAL SUPPLY PLUS
NIGHT RATE OR CONTROLLED SUPPLY WITH CONTACTOR
(ADDITIONS AND ALTERATIONS ONLY)**

QECMM - D.18

NON RIPPLE CONTROL AREAS ONLY

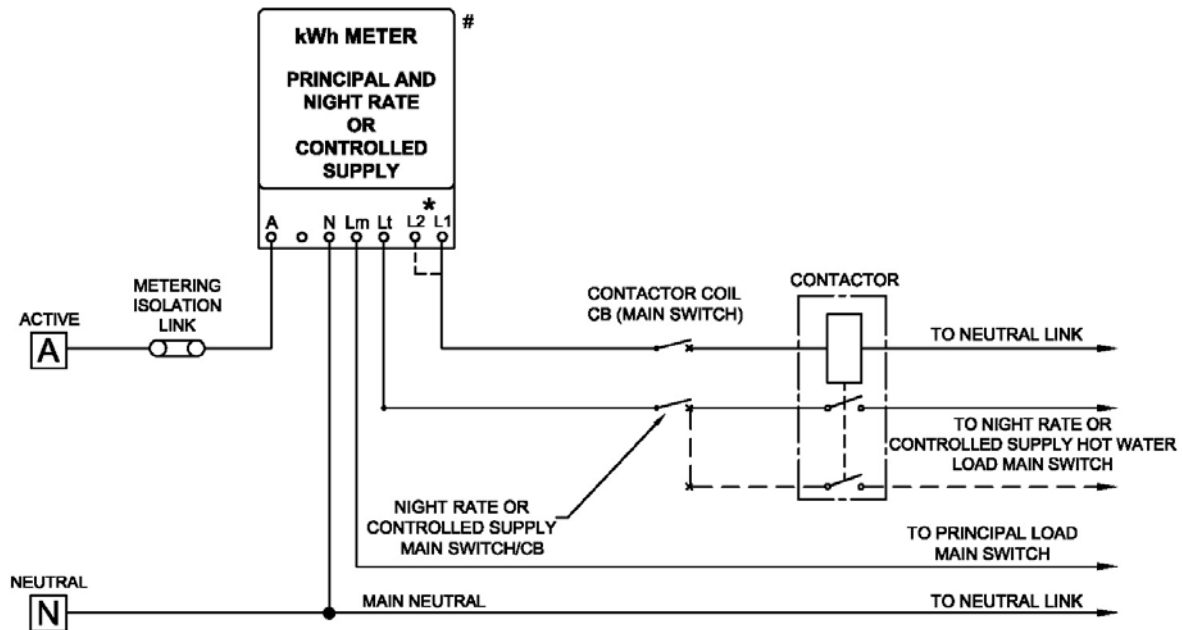

- # ITEMS SUPPLIED BY METERING PROVIDER.
- * SWITCH POSITION DETERMINED BY SUPPLY AND LOAD TYPE.
- SOLDERED CONNECTION.

NOTES:

1. THIS ARRANGEMENT APPLIES TO NON-RIPPLE CONTROL AREAS
2. CUSTOMER TO SUPPLY CONTACTOR ALL WIRING AND ALL ITEMS NOT MARKED WITH "#".
3. CONTACTOR CONTROL CIRCUIT ASSOCIATED WITH SECONDARY SUPPLIES CONNECTED TO SWITCHED TERMINAL L1 OR TERMINAL L2.
4. SECONDARY SUPPLY LOADS CONNECTED VIA CONTACTOR TO UNSWITCHED METER TERMINAL Lt.
5. ELEMENT 1 FOR PRINCIPAL SUPPLY ONLY, ELEMENT 2 FOR EITHER NIGHT RATE OR CONTROLLED LOAD.
6. TWO ELEMENT METER TERMINAL DESCRIPTION.

1	A - ACTIVE IN
3	N - NEUTRAL IN
4	Lm - ELEMENT 1 (MAIN)
5	Lt - ELEMENT 2 (UNSWITCHED)
6/7	L1 & L2 ELEMENT 2 (SWITCHED)

7. ELEMENT 1 FOR PRINCIPAL SUPPLY LOAD ONLY, ELEMENT 2 FOR EITHER NIGHT RATE OR CONTROLLED SUPPLY LOAD.

Revision:

A

**WIRING DIAGRAM - DIRECT CONNECTED METERING
SINGLE PHASE PRINCIPAL SUPPLY PLUS
NIGHT RATE OR CONTROLLED SUPPLY WITH CONTACTOR
(NON RIPPLE CONTROL AREAS ONLY)**

QECMM - D.19

INITIAL CONNECTION AND LIMITED SPACE USE

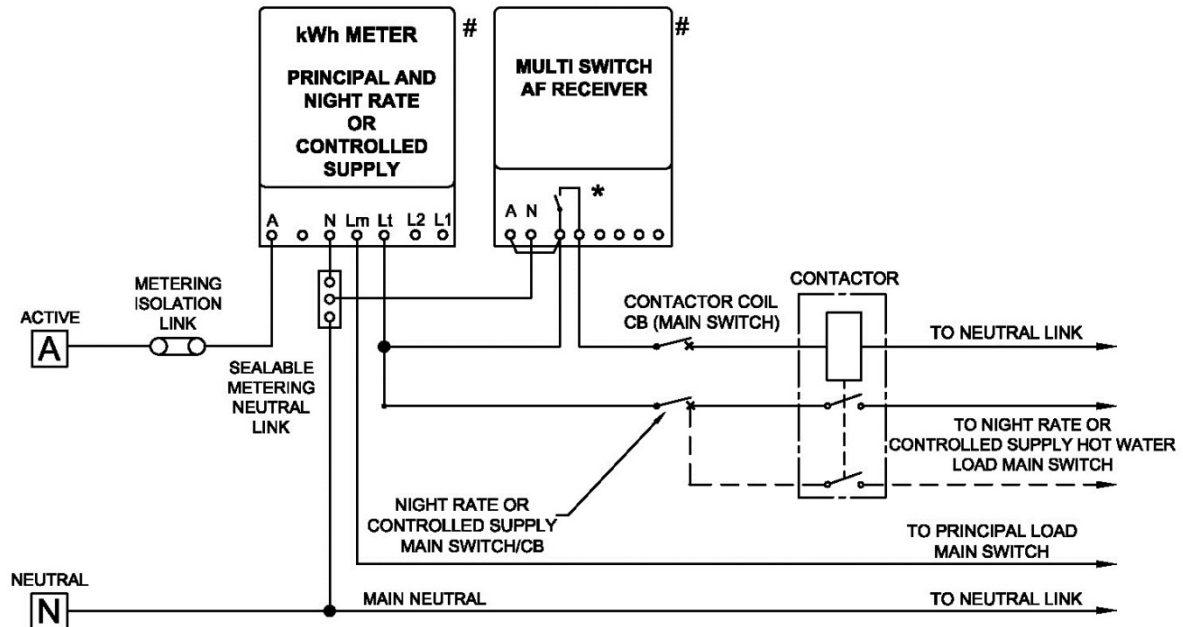

- # ITEMS SUPPLIED BY METERING PROVIDER.
- * SWITCH POSITION DETERMINED BY SUPPLY AND LOAD TYPE.
- SOLDERED CONNECTION.

NOTES:

1. CUSTOMER TO SUPPLY CONTACTOR ALL WIRING AND ALL ITEMS NOT MARKED WITH "#".
2. SECONDARY SUPPLY LOADS CONNECTED TO UNSWITCHED METER TERMINAL Lt.
3. ELEMENT 1 FOR PRINCIPAL LOAD ONLY, ELEMENT 2 FOR EITHER NIGHT RATE OR CONTROLLED LOAD.
4. SECONDARY SUPPLY CONTACTOR CONTROLLED VIA AF RECEIVER.
5. TWO ELEMENT METER TERMINAL DESCRIPTION.

1	A - ACTIVE IN
3	N - NEUTRAL IN
4	Lm - ELEMENT 1 (MAIN)
5	Lt - ELEMENT 2 (UNSWITCHED)
6, 7	L1 & L2 NOT USED IN RIPPLE AREAS

6. ELEMENT 1 FOR PRINCIPAL SUPPLY LOAD ONLY, ELEMENT 2 FOR EITHER NIGHT RATE OR CONTROLLED SUPPLY LOAD.

Revision:

A

**WIRING DIAGRAM - DIRECT CONNECTED METERING
SINGLE PHASE PRINCIPAL SUPPLY PLUS
NIGHT RATE OR CONTROLLED SUPPLY WITH CONTACTOR
(INITIAL CONNECTION AND LIMITED SPACE USE)**

QECMM - D.20

INITIAL CONNECTION AND LIMITED SPACE USE

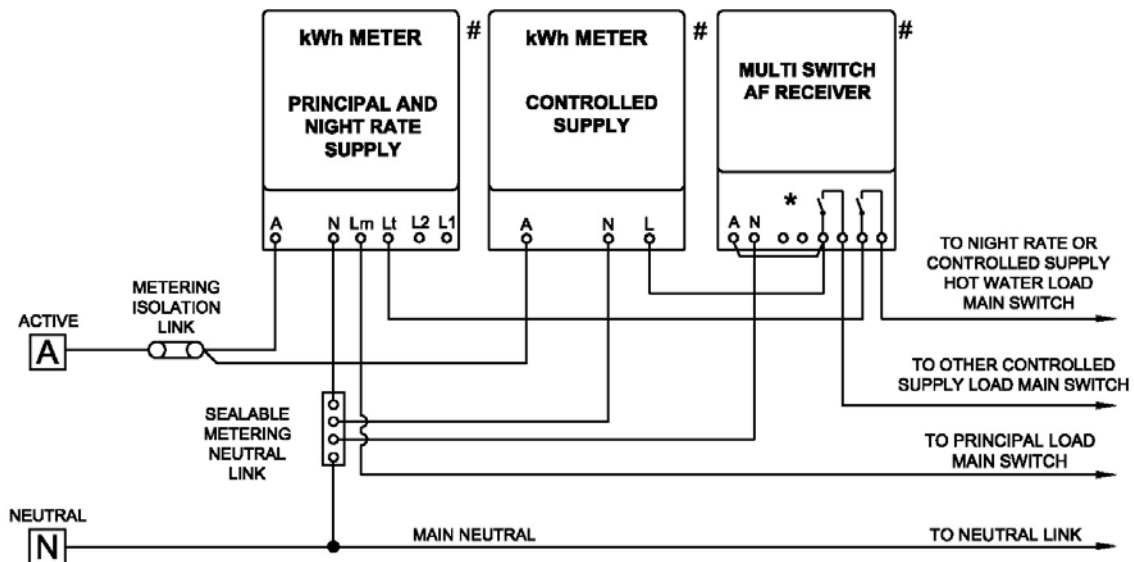

- # ITEMS SUPPLIED BY METERING PROVIDER.
- * SWITCH POSITION DETERMINED BY SUPPLY AND LOAD TYPE.
- SOLDERED CONNECTION.

NOTES:

1. FOR CONTROLLED SUPPLY LOADS, WHERE RESISTIVE LOAD EXCEEDS 30A OR WHERE RESISTIVE AND A INDUCTIVE LOAD EXCEEDS 20A, CONTACTOR SHALL BE USED. (SEE DRAWING ECMM 8.12).
2. SECONDARY SUPPLY SWITCHING IS DONE BY AF RECEIVERS.
3. CONTROLLED CIRCUIT ASSOCIATED WITH NIGHT RATE SUPPLY CONNECTED TO UNSWITCHED TERMINAL Lt OF TWO ELEMENT METER.
4. TWO ELEMENT METER TERMINAL DESCRIPTION.

1	A - ACTIVE IN
3	N - NEUTRAL IN
4	Lm - ELEMENT 1 (MAIN)
5	Lt - ELEMENT 2 (UNSWITCHED)
6, 7	L1 & L2 NOT USED IN RIPPLE AREAS

5. ELEMENT 1 FOR PRINCIPAL SUPPLY LOAD ONLY, ELEMENT 2 FOR EITHER NIGHT RATE OR CONTROLLED SUPPLY LOAD.

Revision:

A

**WIRING DIAGRAM - DIRECT CONNECTED METERING
SINGLE PHASE PRINCIPAL SUPPLY PLUS
NIGHT RATE AND CONTROLLED SUPPLIES
(INITIAL CONNECTION AND LIMITED SPACE USE)**

QECMM - D.21

INITIAL CONNECTION AND LIMITED SPACE USE

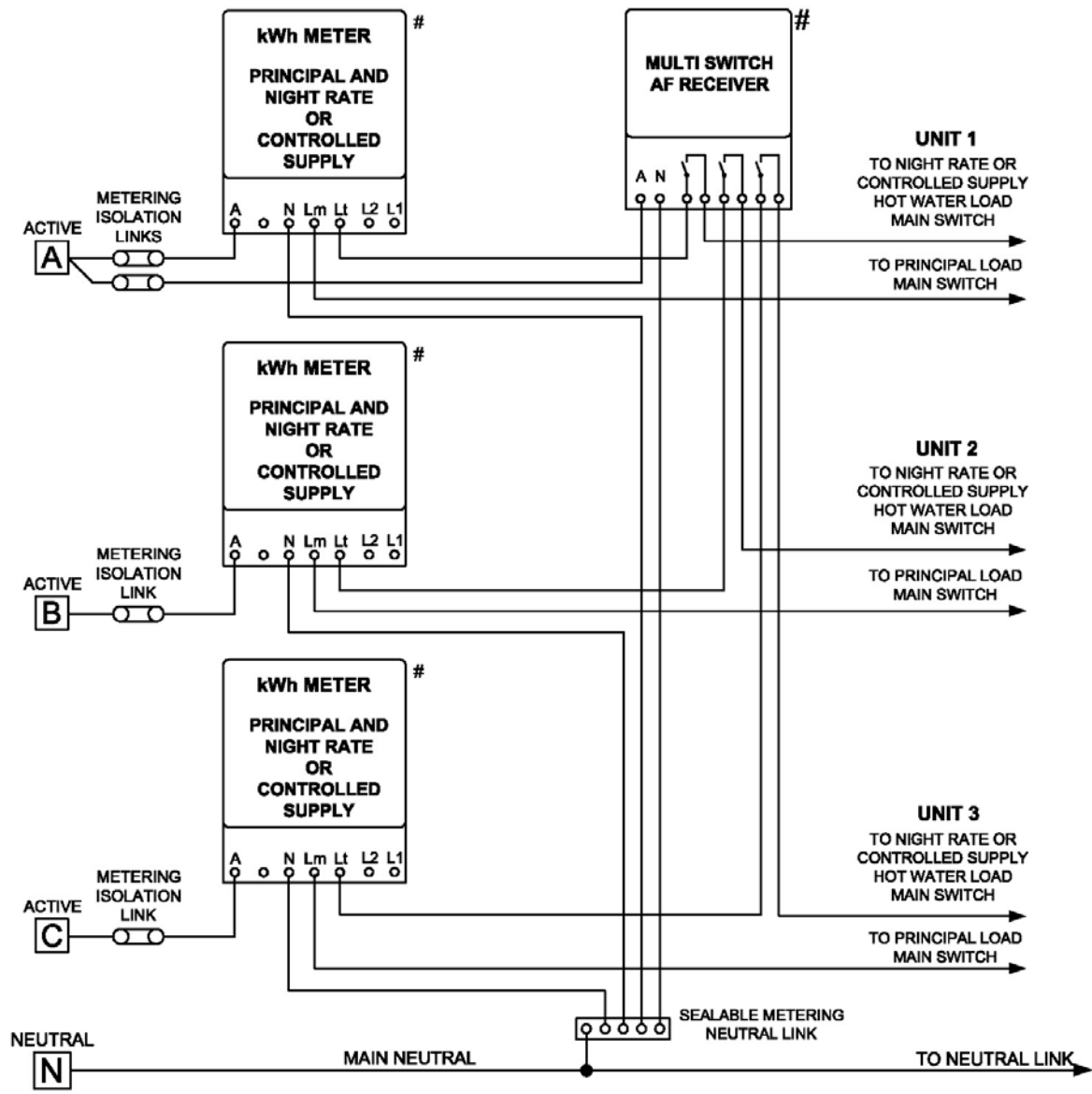

ITEMS SUPPLIED BY METERING PROVIDER.
● SOLDERED CONNECTION.

NOTES:

1. TERMINAL CONNECTIONS TO BE MADE ACCORDING TO THE TYPE OF RELAY.
2. WHERE POSSIBLE THE INDIVIDUAL SWITCHES OF EACH MULTI SWITCH AF RECEIVER SHOULD BE CONNECTED TO THE SAME PHASE.
3. INSTALL APPROVED BACK WIRED METERING ISOLATION LINKS.
NOTE: WHERE METER NOT INSTALLED REMOVE SOLID LINK TO ENSURE NO EXPOSED LIVE TAILS.
4. WHERE THE SERVICE FUSE IS GREATER THAN 100 AMPS, THE METERING LINKS ARE TO BE REPLACED BY 100A HRC FUSE CARTRIDGES.
5. METERS, METERING ISOLATION LINKS, METERING NEUTRAL LINK, AF RECEIVERS AND ACTIVE/NEUTRAL LINKS ARE TO BE SEALED BY METERING PROVIDER/DISTRIBUTOR.
6. AN INSTALLATION ISOLATOR OR LOCKABLE CB MAIN SWITCH IS REQUIRED ON THE LINE SIDE OF THE METERING.

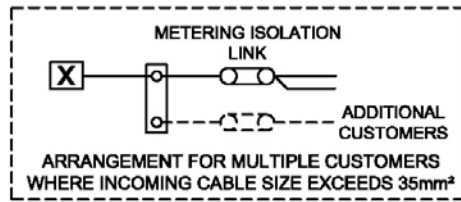

Revision: A	WIRING DIAGRAM - DIRECT CONNECTED METERING SINGLE PHASE PRINCIPAL SUPPLY PLUS NIGHT RATE OR CONTROLLED SUPPLY MULTIPLE INSTALLATIONS (INITIAL CONNECTION AND LIMITED SPACE USE)	QECMM - D.22
------------------------------	--	---------------------

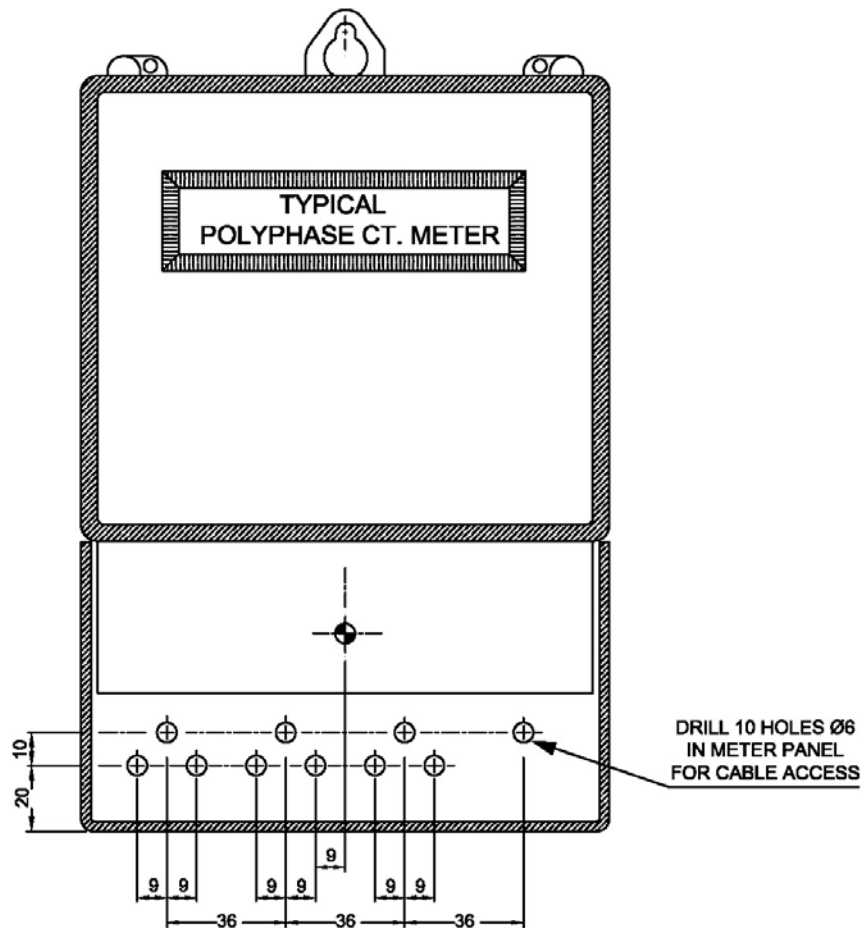

Revision:
A

**DRILLING DETAILS FOR CABLE ACCESS
POLYPHASE CT. kWh METER**

QECMM - D.23